

# C1005X8R1E223K050BE

TDK Item Description : C1005X8R1E223KT\*\*\*S



## Application & Main Feature

Commercial Grade ( Soft Termination )

## Series

C1005 [EIA CC0402]

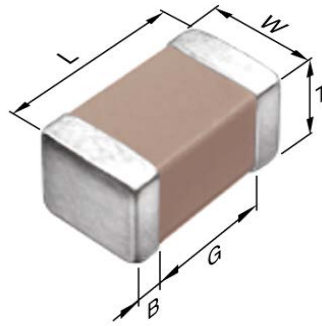

## Dimensions

L	1.00mm +0.15,-0.05mm
W	0.50mm +0.1,-0.05mm
T	0.50mm +0.1,-0.05mm
B	0.10mm Min.
G	0.30mm Min.

## Temperature Characteristic

X8R (-55 to 150 degC +/-15%)

## Rated Voltage

1E (25Vdc)

## Capacitance

22nF

## Capacitance Tolerance

K (+/-10%)

## Dissipation Factor

3% Max.

## Insulation Resistance

10Gohm Min

## AEC-Q200

Not Applicable

## |Z|, ESR vs. Freq. Characteristics (Simulation Data)

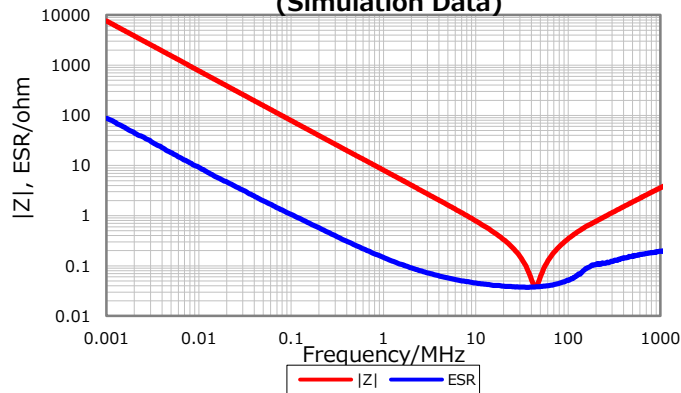

## Cap. vs. Freq. Characteristic

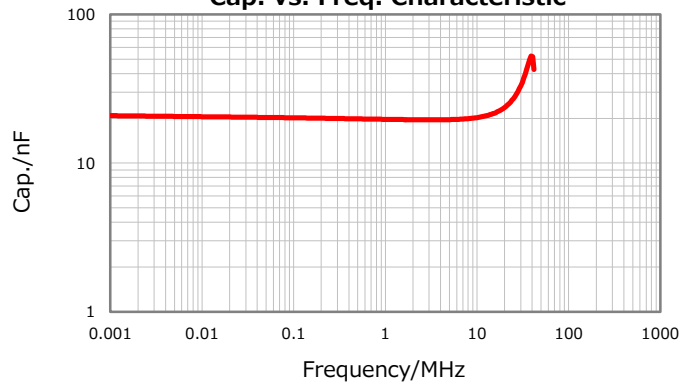

## DC Bias Characteristic

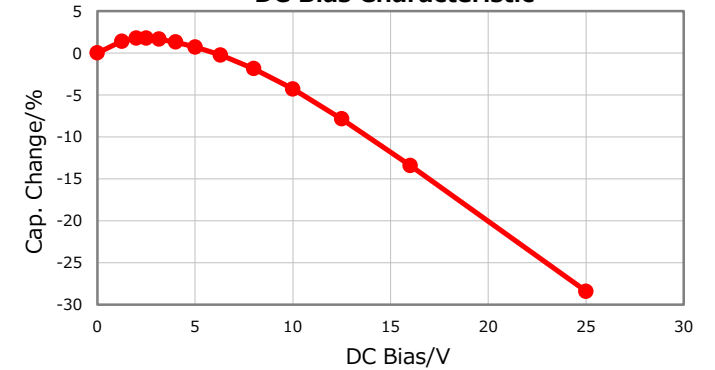

## Temperature Characteristics

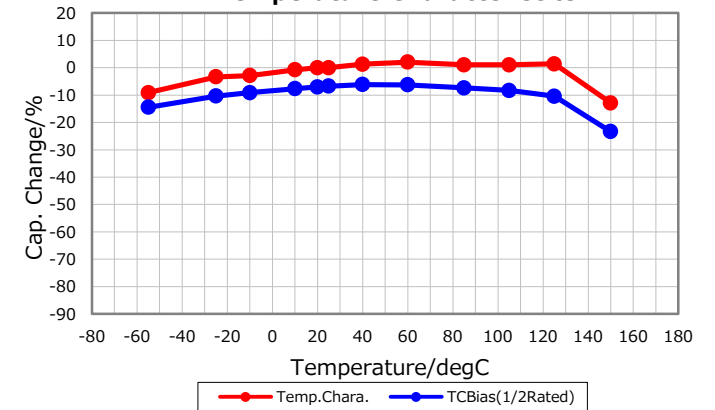

## Ripple Temperature Rise Characteristics

