

C1608X6S0G226M080AC

TDK item description : C1608X6S0G226MT****



Application & Main Feature

Commercial grade (General type)

Series

C1608 [EIA 0603]

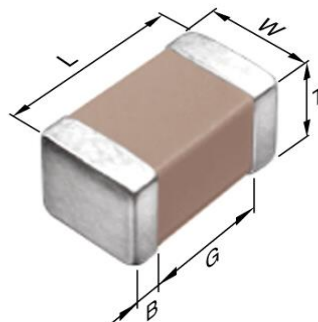

Dimensions

| | |
|---|--------------|
| L | 1.60±0.20 |
| W | 0.80±0.20 |
| T | 0.80±0.20 |
| B | 0.20 mm min. |
| G | 0.30 mm min. |

Temperature Characteristic

X6S (-55 to +105 degC, ±22%)

Rated Voltage

0G (4Vdc)

Capacitance

22µF

Capacitance Tolerance

M (±20%)

DF

10 % max.

Insulation Resistance

4 Mohm min.

AEC-Q200

Not Applicable

