

C2012JB1C335K060AC

TDK Item Description : C2012JB1C335KT***



Application & Main Feature

Commercial Grade(Up to 50V)

Series

C2012 [EIA 0805]

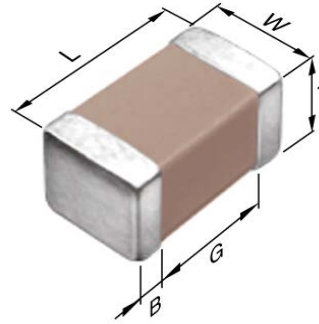

Dimensions

L	2.00mm ±0.20mm
W	1.25mm ±0.20mm
T	0.60mm ±0.15mm
B	0.20mm Min.
G	0.50mm Min.

Temperature Characteristic

JB (-25 to 85 degC +/-10%)

Rated Voltage

1C(16Vdc)

Capacitance

3.3uF

Capacitance Tolerance

K (±10%)

Dissipation Factor

10% Max.

Insulation Resistance

30Mohm Min.

AEC-Q200

Not Applicable

|Z|, ESR vs. Freq. Characteristics

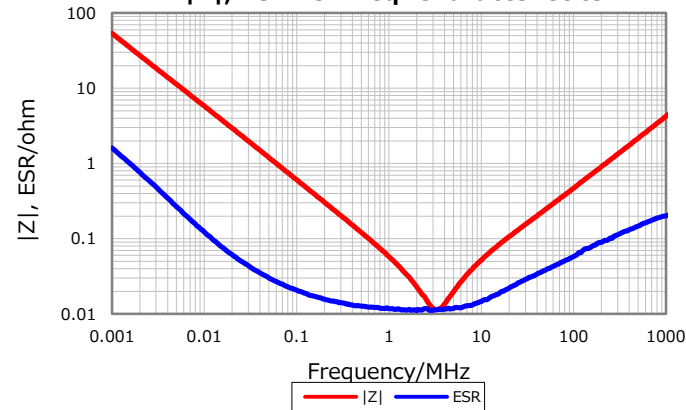

Cap. vs. Freq. Characteristic

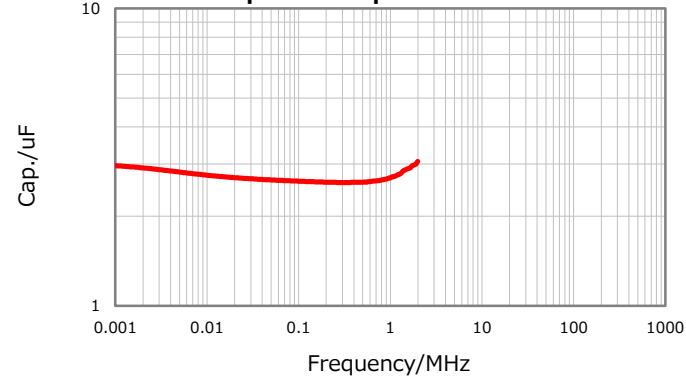

DC Bias Characteristic

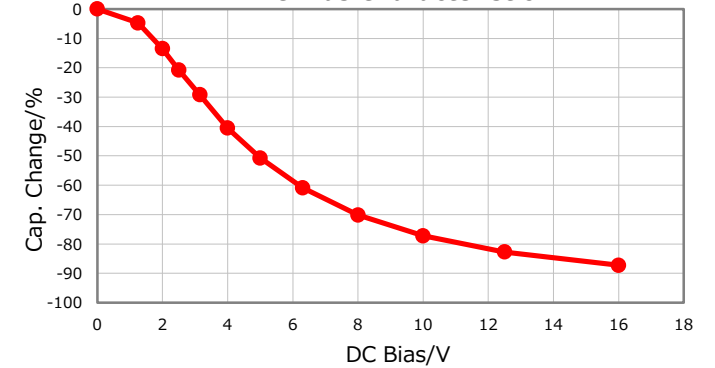

Temperature Characteristics

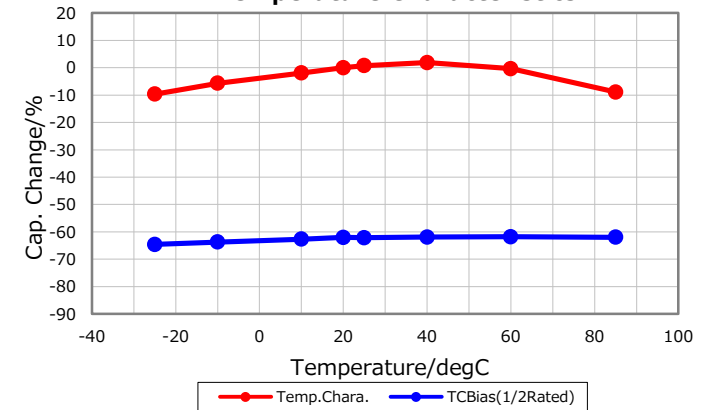

Ripple Temperature Rise Characteristics

