

CGA4J1X8L1A106K125AC

TDK item description : CGA4J1X8L1A106KT****



Equivalent C2012X8L1A106K for Automotive

Application & Main Feature

Automotive grade (General type)

Series

CGA4(2012) [EIA 0805]

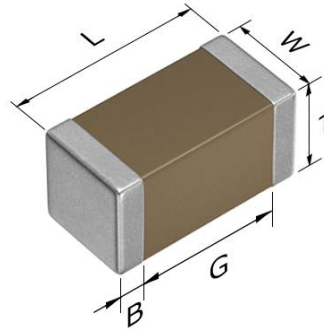

Dimensions

L	2.00+0.25,-0.15 mm
W	1.25+0.25,-0.15 mm
T	1.25+0.25,-0.15 mm
B	0.20 mm min.
G	0.50 mm min.

Temperature Characteristic

X8L (-55 to +150 degC, +15/-40%)

Rated Voltage

1A (10Vdc)

Capacitance

10 μ F

Capacitance Tolerance

K (\pm 10%)

DF

7.5 % max.

Insulation Resistance

10 Mohm min.

AEC-Q200

Yes

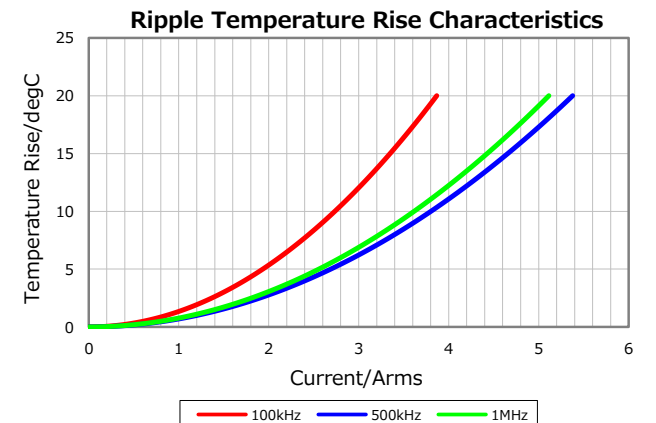
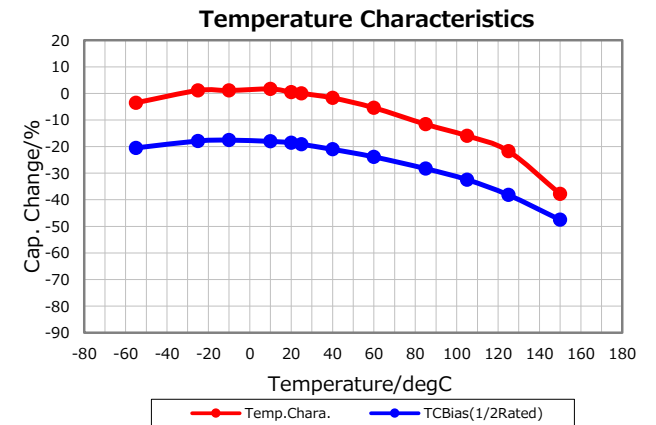
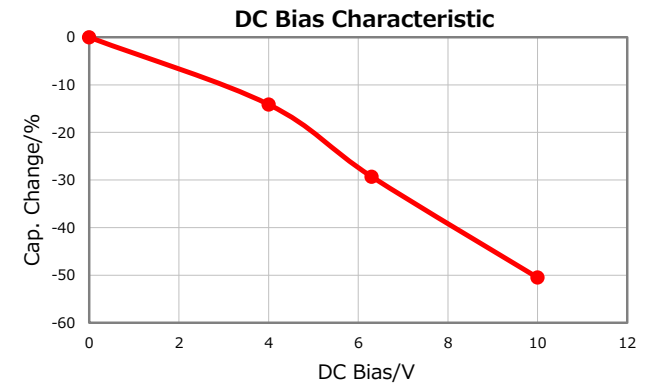
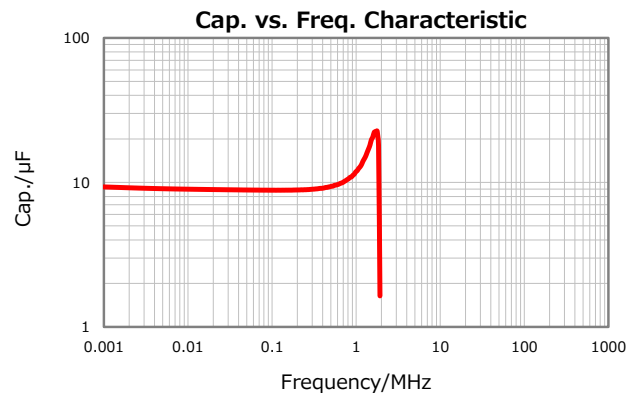
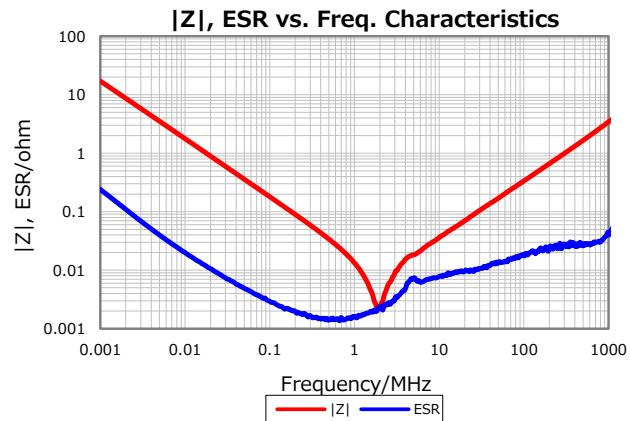

Characterization Sheet (Multilayer Ceramic Chip Capacitors)



All specifications are subject to change without notice.

October 20, 2021