

# CGA5L3X5R1E106M160AB

TDK item description : CGA5L3X5R1E106MT\*\*\*\*



Equivalent C3216X5R1E106M for Automotive

## Application & Main Feature

Automotive grade (General type)

## Series

CGA5(3216) [EIA 1206]

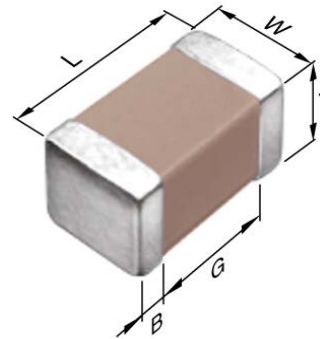

## Dimensions

L	3.20+0.30/-0.10 mm
W	1.60+0.30/-0.10 mm
T	1.60+0.30/-0.10 mm
B	0.20 mm min.
G	1.00 mm min.

## Temperature Characteristic

X5R (-55 to +85 degC, ±15%)

## Rated Voltage

1E (25Vdc)

## Capacitance

10µF

## Capacitance Tolerance

M (±20%)

## Dissipation Factor

7.5 % max.

## Insulation Resistance

50 Mohm min.

## AEC-Q200

Yes

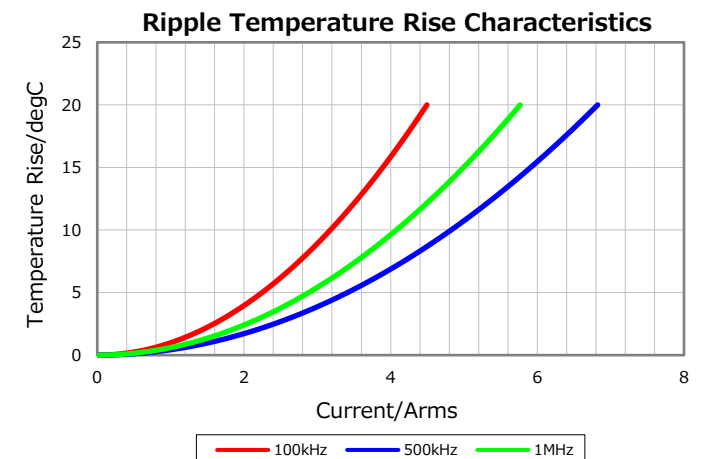
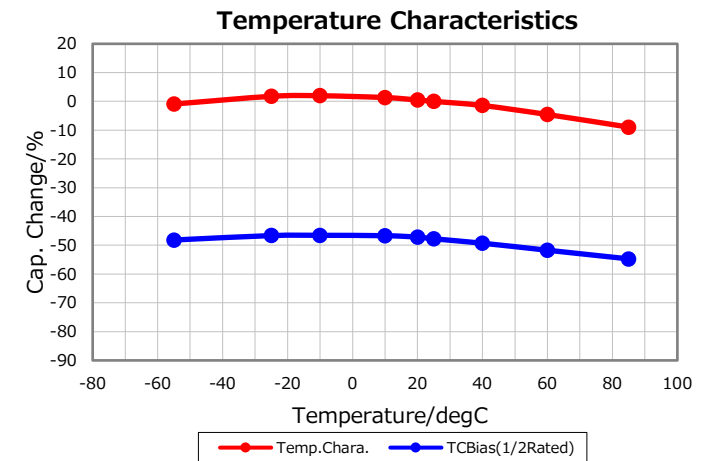
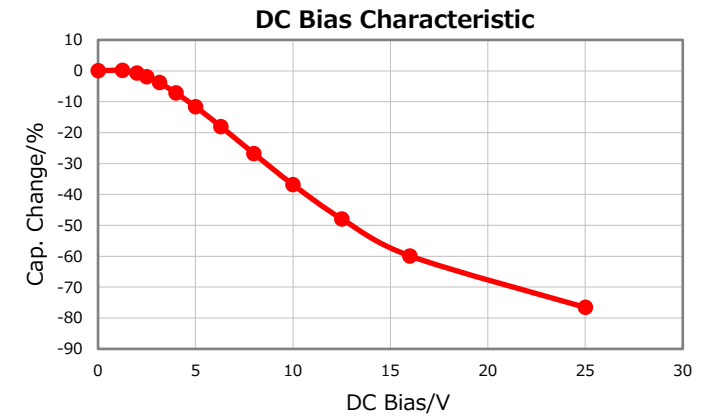
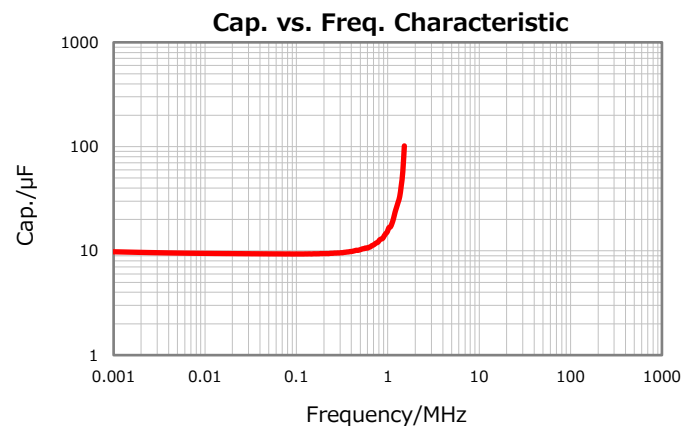
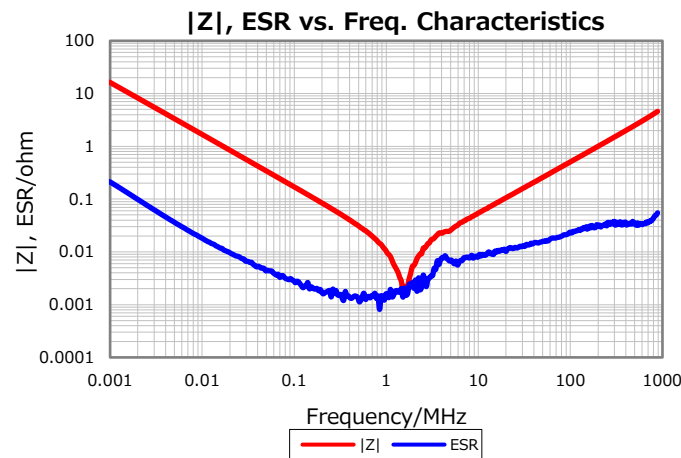

Characterization Sheet ( Multilayer Ceramic Chip Capacitors )



All specifications are subject to change without notice.

January 22, 2020