

**NOTES**

- A: MODEL NAME, INPUT VOLTAGE RANGE, NOMINAL OUTPUT VOLTAGE, MAXIMUM OUTPUT CURRENT, COUNTRY OF MANUFACTURE AND SAFETY MARKING (FOR ONLY APPROVED PRODUCTS) ARE SHOWN HERE IN ACCORDANCE WITH THE SPECIFICATIONS.
- B: M4 EMBOSSED, TAPPED AND COUNTERSUNK HOLES (4) FOR CUSTOMER CHASSIS MOUNTING. SCREWS MUST NOT PROTRUDE INTO POWER SUPPLY BY MORE THAN 6m/m.
- C:  $\phi 4.5$  HOLE FOR CUSTOMER CHASSIS MOUNTING. (USE M4 MOUNTING SCREW.)
- D: REMOTE ON/OFF CONTROL CONNECTOR --- OPTION B2B-XH-AM (JST)

**ACCESSORIES**

- \* COVER FOR BARRIER STRIP TERMINAL
- \* HOUSING: XHP-2 (JST), TERMINAL: BXH-001T-P0.6 (JST) OR SXH-001T-P0.6 (JST) --- OPTION  
HAND CRIMPING TOOL : YC-110 (JST) OR YRS-110 (JST)

**OPTIONAL MODELS**

MODEL	COVER	REMOTE ON/OFF CONTROL
JWT75-*		
JWT75-* [A]	○	
JWT75-* [R]		○
JWT75-* [RA]	○	○

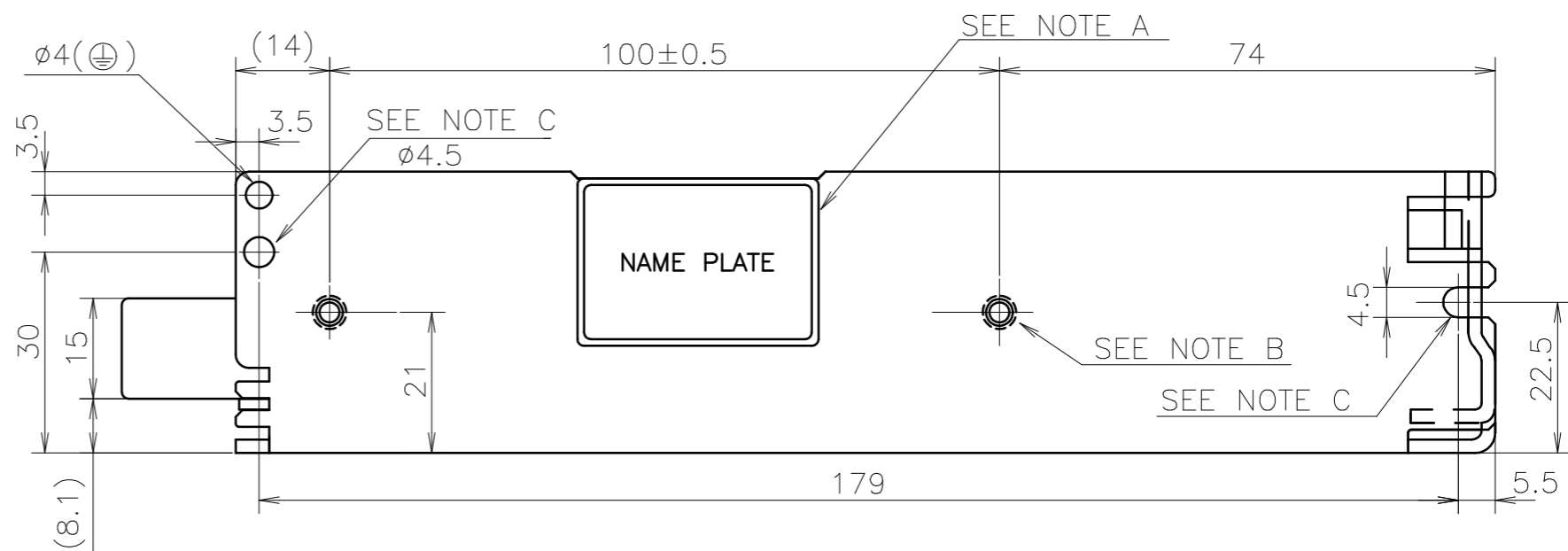

(unit : mm)

MODEL NAME	JWT75
<b>TDK-Lambda</b>	

A178-02-01H