

HWS3000G-24

EVALUATION DATA

型式データ

INDEX

	PAGE
1. 測定方法 Evaluation Method	
1-1. 測定回路 Circuit used for determination	
測定回路1 Circuit 1 used for determination	4
静特性 Steady state data	
通電ドリフト特性 Warm up voltage drift characteristics	
出力保持時間特性 Hold up time characteristics	
出力電圧立ち上がり/立ち下がり特性 Output voltage rise/fall characteristics	
出力電流立ち上がり/立ち下がり特性 Output current rise/fall characteristics	
過電流保護特性 Over current protection (OCP) characteristics	
入力電圧瞬停特性 Response to brown out characteristics	
入力電流波形 Input current waveform	
過渡応答(負荷急変)特性 Dynamic load response characteristics	
出力リップル、ノイズ電流波形 Output ripple and noise current waveform	
測定回路2 Circuit 2 used for determination	4
リーク電流特性 Leakage current characteristics	
測定回路3 Circuit 3 used for determination	5
過電圧保護特性 Over voltage protection (OVP) characteristics	
測定回路4 Circuit 4 used for determination	5
入力サージ電流(突入電流)波形 Inrush current waveform	
測定回路5 Circuit 5 used for determination	5
高調波成分 Input current harmonics	
測定回路6 Circuit 6 used for determination	6
ON/OFFコントロール時出力立ち上がり、立ち下がり特性	
Output rise, fall characteristics with ON/OFF Control	
測定回路7 Circuit 7 used for determination	7
出力リップル、ノイズ電圧波形 Output ripple and noise voltage waveform	
測定構成 Configuration used for determination	7
EMI特性 Electro-Magnetic Interference characteristics	
(a) 雑音端子電圧(帰還ノイズ) Conducted Emission	
(b) 雑音電界強度(放射ノイズ) Radiated Emission	
1-2. 使用測定機器 List of equipment used	8
2. 特性データ Characteristics	
2-1. 定電圧出力モード Constant voltage output mode	
2-1-1. 静特性 Steady state data	
(1) 入力・負荷・温度変動 Regulation - line and load, Temperature drift	9
(2) リップルノイズ電圧対出力電流 Ripple noise voltage vs. Output current	10
(3) 効率・力率対出力電流 Efficiency and Power factor vs. Output current	11
(4) 入力電力対出力電流 Input power vs. Output current	12
(5) 入力電流対出力電流 Input current vs. Output current	13
2-1-2. 通電ドリフト特性 Warm up voltage drift characteristics	14
2-1-3. 出力保持時間特性 Hold up time characteristics	14
2-1-4. 出力電圧立ち上がり特性 Output voltage rise characteristics	15

	PAGE
2-1-5. 出力電圧立ち下がり特性 Output voltage fall characteristics	16
2-1-6. ON/OFFコントロール時出力立ち上がり、立ち下がり特性 Output rise, fall characteristics with ON/OFF Control	
(a) リモートON/OFFコントロール端子によるON/OFF ON/OFF control by remote ON/OFF control terminal	17-18
(b) RS-485通信によるON/OFF ON/OFF control by RS-485	19-20
2-1-7. 過渡応答(負荷急変)特性 Dynamic load response characteristics	21
2-1-8. 入力電圧瞬停特性 Response to brown out characteristics	22
2-1-9. 出力リップル、ノイズ波形 Output ripple and noise waveform	22
2-2. 定電流出力モード Constant current output mode	
2-2-1. 静特性 Steady state data	
(1) 入力・負荷・温度変動 Regulation - line and load, Temperature drift	23
(2) リップルノイズ電流対出力電圧 Ripple noise current vs. Output voltage	24
(3) 効率・力率対出力電圧 Efficiency and Power factor vs. Output voltage	25
(4) 入力電力対出力電圧 Input power vs. Output voltage	26
(5) 入力電流対出力電圧 Input current vs. Output voltage	27
2-2-2. 通電ドリフト特性 Warm up current drift characteristics	28
2-2-3. 出力電流立ち上がり特性 Output current rise characteristics	29
2-2-4. 出力電流立ち下がり特性 Output current fall characteristics	30
2-2-5. ON/OFFコントロール時出力立ち上がり、立ち下がり特性 Output rise, fall characteristics with ON/OFF Control	
(a) リモートON/OFFコントロール端子によるON/OFF ON/OFF control by remote ON/OFF control terminal	31-32
(b) RS-485通信によるON/OFF ON/OFF control by RS-485	33-34
2-2-6. 入力電圧瞬停特性 Response to brown out characteristics	35
2-2-7. 出力リップル、ノイズ波形 Output ripple and noise waveform	35
2-3. 過電流保護特性 Over current protection (OCP) characteristics	36
2-4. 過電圧保護特性 Over voltage protection (OVP) characteristics	37
2-5. 入力サージ電流(突入電流)波形 Inrush current waveform	38
2-6. 高調波成分 Input current harmonics	39
2-7. 入力電流波形 Input current waveform	39
2-8. リーク電流特性 Leakage current characteristics	40
2-9. EMI特性 Electro Magnetic Interference characteristics	41-44

使用記号Terminology used

Ta : 周囲温度 Ambient temperature	f : 周波数 Frequency
Vin : 入力電圧 Input voltage	Iin : 入力電流 Input current
Vout : 出力電圧 Output voltage	Iout : 出力電流 Output current
Vaux : AUX電圧 AUX voltage	Iaux : AUX電流 AUX current

※ 当社測定条件における結果であり、参考値としてお考え願います。
Test results are reference data based on our measurement condition.

1. 測定方法 Evaluation Method

1-1. 測定回路 Circuit used for determination

測定回路1 Circuit 1 used for determination

静特性 Steady state data

通電ドリフト特性 Warm up voltage drift characteristics

出力保持時間特性 Hold up time characteristics

出力電圧立ち上がり/立ち下がり特性 Output voltage rise/fall characteristics

出力電流立ち上がり/立ち下がり特性 Output current rise/fall characteristics

過電流保護特性 Over current protection (OCP) characteristics

入力電圧瞬停特性 Response to brown out characteristics

入力電流波形 Input current waveform

過渡応答（負荷急変）特性 Dynamic load response characteristics

出力リップル、ノイズ電流波形 Output ripple and noise current waveform

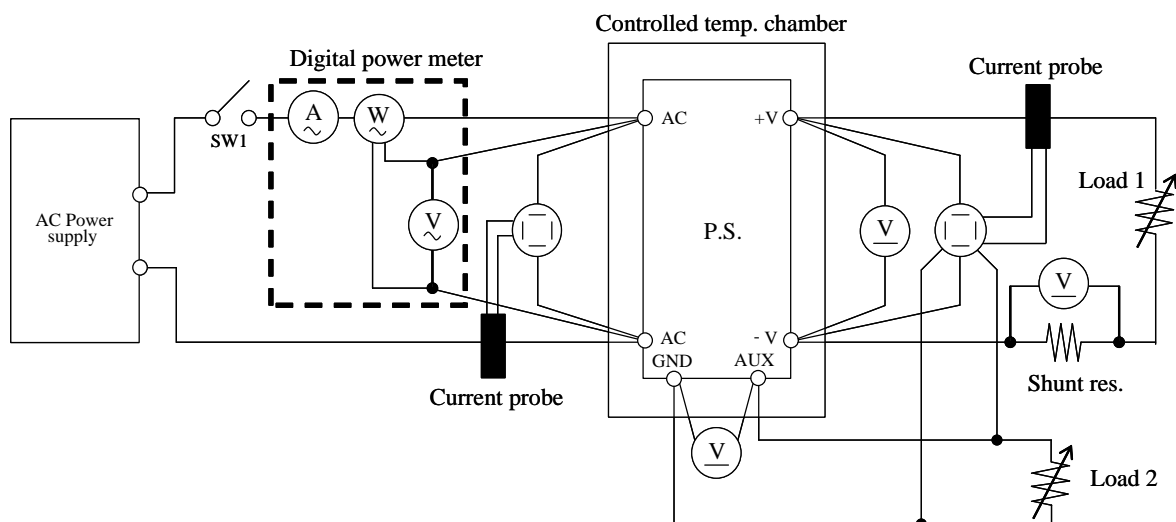

測定回路2 Circuit 2 used for determination

リーク電流特性 Leakage current characteristics

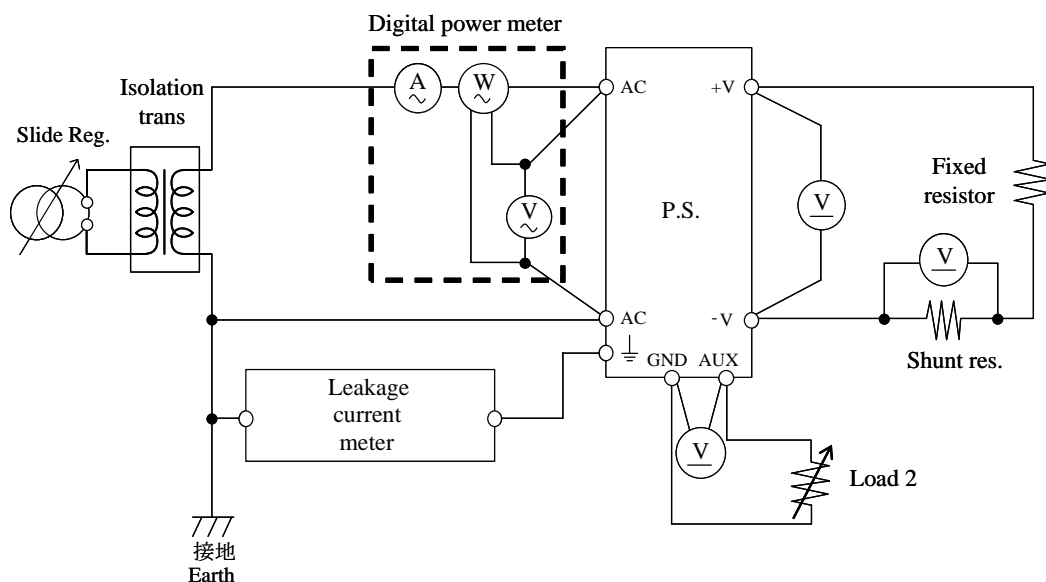

測定回路3 Circuit 3 used for determination

過電圧保護特性 Over voltage protection (OVP) characteristics

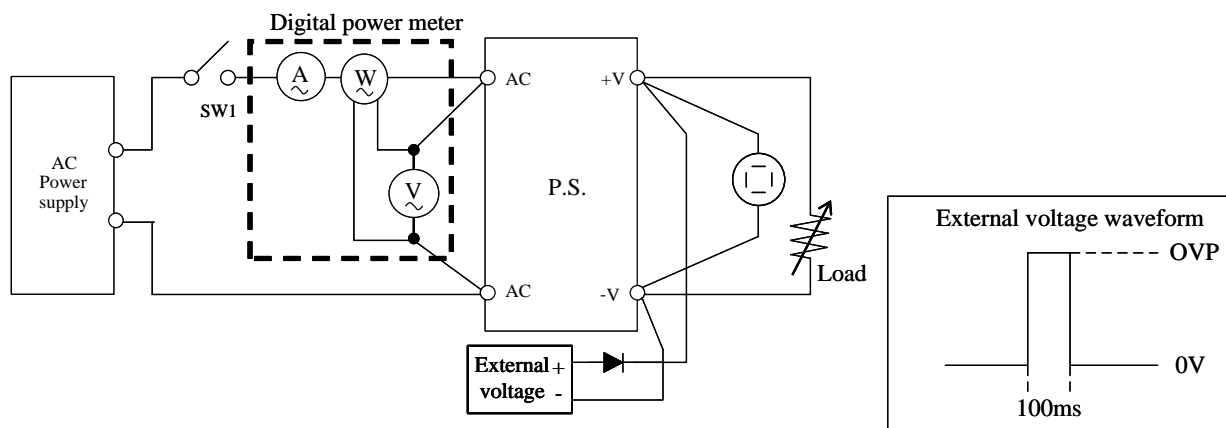

測定回路4 Circuit 4 used for determination

入力サージ電流 (突入電流) 波形 Inrush current waveform

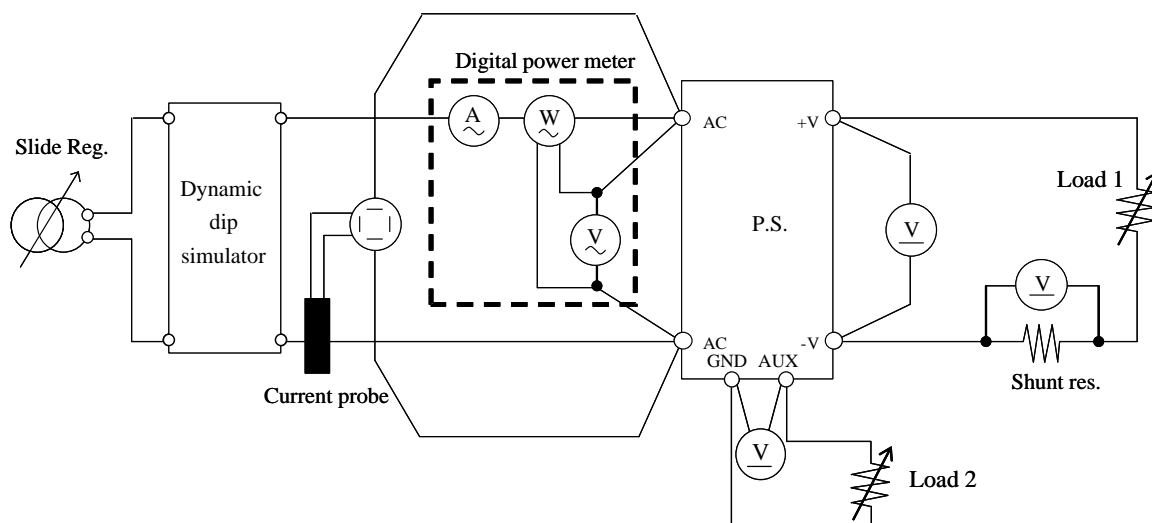

測定回路5 Circuit 5 used for determination

高調波成分 Input current harmonics

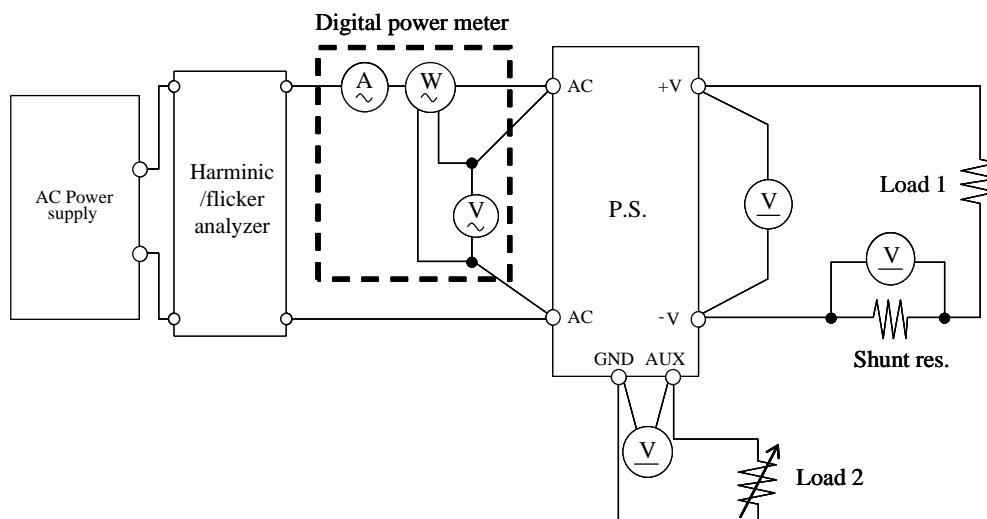

測定回路6 Circuit 6 used for determination

ON/OFFコントロール時出力立ち上がり、立ち下がり特性
Output rise, fall characteristics with ON/OFF Control

(a) リモートON/OFFコントロール端子によるON/OFF
ON/OFF control by remote ON/OFF control terminal

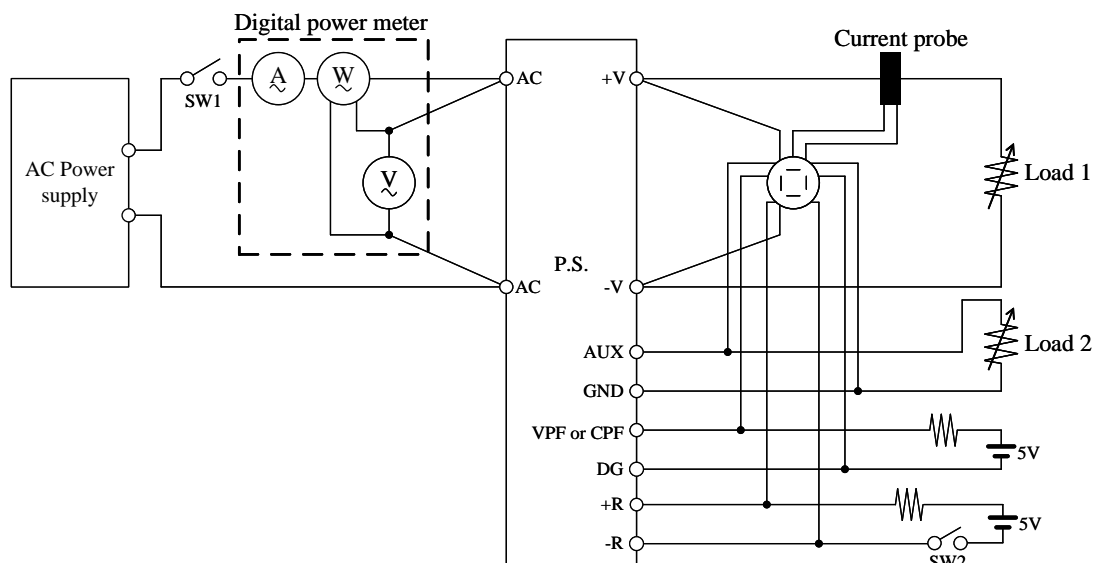

(b) RS-485通信によるON/OFF ON/OFF control by RS-485

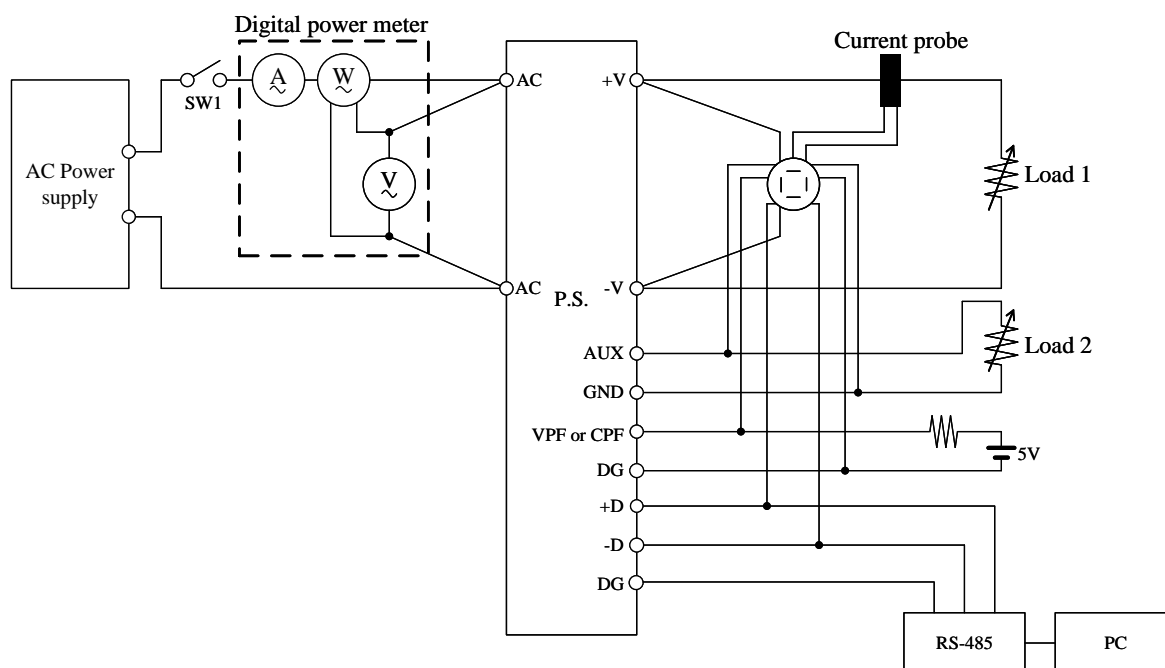

測定回路7 Circuit 7 used for determination

出力リップル、ノイズ電圧波形 Output ripple and noise voltage waveform

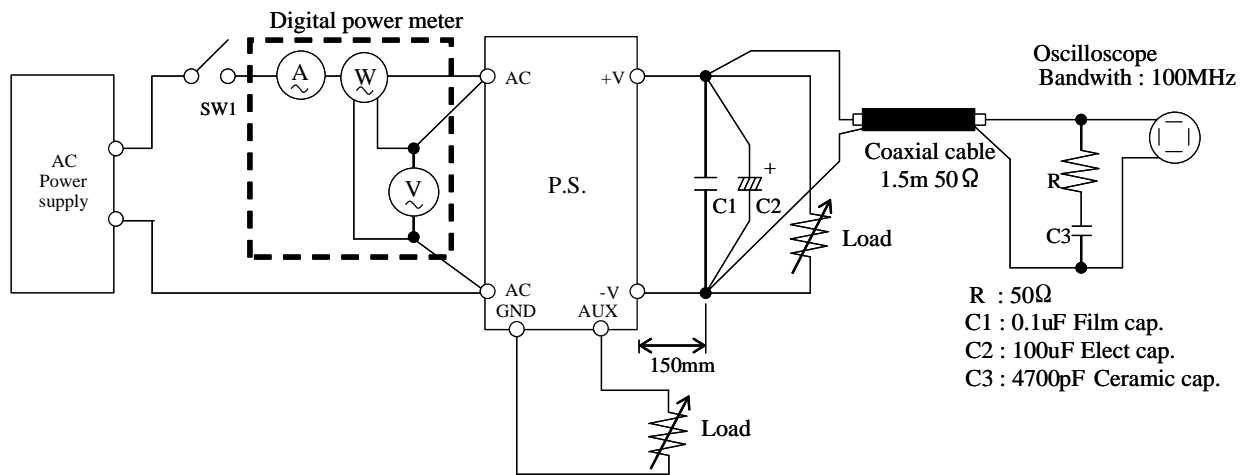

測定構成 Configuration used for determination

EMI特性 Electro-Magnetic Interference characteristics

(a) 雑音端子電圧 (帰還ノイズ) Conducted Emission

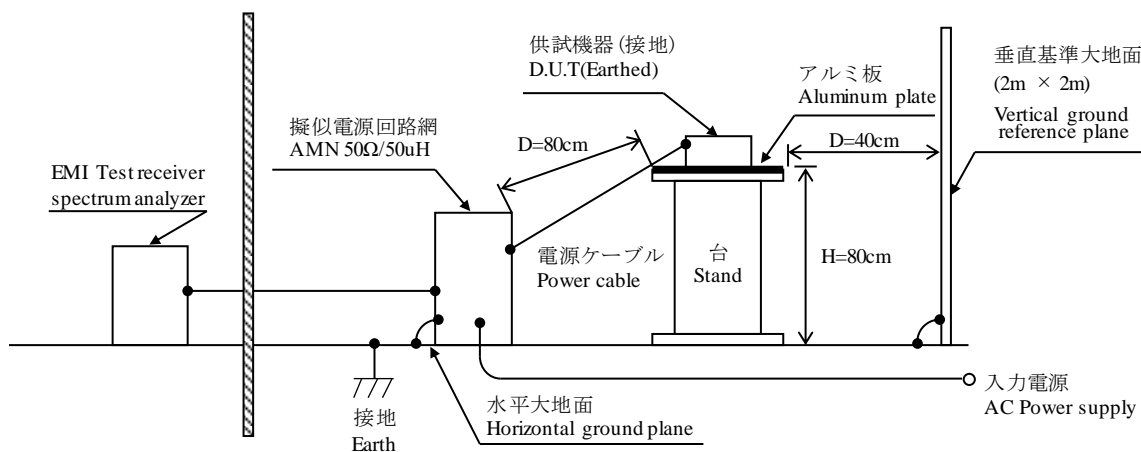

(b) 雑音電界強度 (放射ノイズ) Radiated Emission

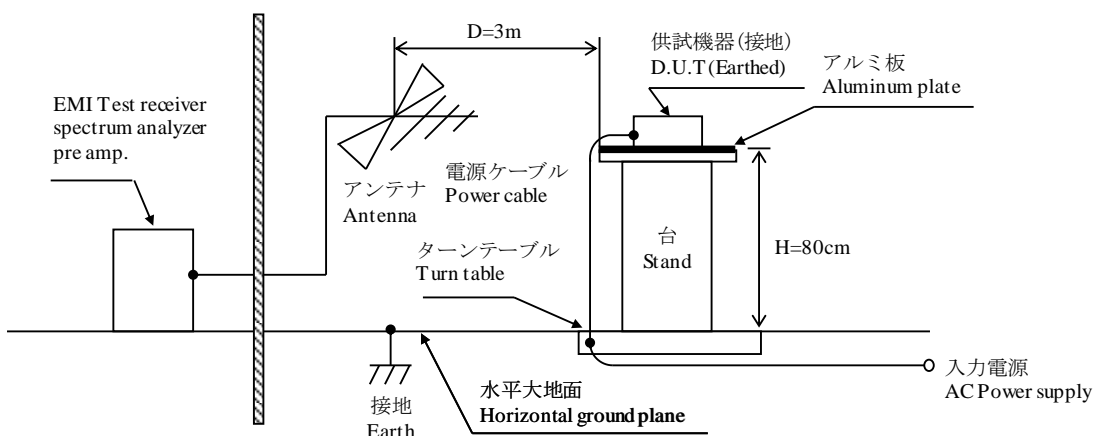

1-2. 使用測定機器 List of equipment used

	EQUIPMENT USED	MANUFACTURER	MODEL NO.
1	DIGITAL STORAGE OSCILLOSCOPE	YOKOGAWA ELECT.	DLM2054
2	DIGITAL MULTIMETER	KEYSIGHT	34970A
3	DIGITAL POWER METER	HIOKI	PW3337
4	CURRENT PROBE	YOKOGAWA ELECT.	701930
5	DYNAMIC DUMMY LOAD	KIKUSI	PLZ10005WSR
6	CVCF	KIKUSUI	PCR18000WEA2R
7	CONTROLLED TEMP. CHAMBER	ESPEC	PSL-4J
8	DYNAMIC DUMMY LOAD	TAKASAGO	FK-200L
9	LEAKAGE CURRENT METER	HIOKI	ST5540
10	EMI TEST RECEIVER / SPECTRUM ANALYZER	ROHDE & SCHWARZ	ESR3
11	PRE AMP.	SONOMA	310N
12	AMN	SCHWARZBECK	NNLK8121
13	ANTENNA	TESEQ	CBL6111D
14	HARMONIC / FLICKER ANALYZER	KIKUSUI	KHA1000
15	SINGLE-PHASE MASTER	NF	4420
16	REFERENCE IMPEDANCE NETWORK 20A	NF	4150
17	MULTI OUTLET UNIT	KIKUSUI	OT01-KHA

2. 特性データ Characteristics

2-1. 定電圧出力モード Constant voltage output mode

2-1-1. 静特性 Steady state data

(1) 入力・負荷・温度変動 Regulation - line and load, Temperature drift

1. Regulation - line and load

Condition Ta : 25 °C

Iout \ Vin	85VAC	100VAC	115VAC	132VAC	Line regulation	
0A	24.123V	24.122V	24.123V	24.120V	3mV	0.013%
31.25A	23.974V	23.973V	23.971V	23.975V	4mV	0.017%
62.5A	23.977V	23.977V	23.980V	23.982V	5mV	0.021%
Load regulation	149mV	149mV	152mV	145mV		
	0.621%	0.621%	0.633%	0.604%		

Iout \ Vin	170VAC	200VAC	230VAC	265VAC	Line regulation	
0A	24.118V	24.119V	24.121V	24.118V	3mV	0.013%
62.5A	23.973V	23.975V	23.974V	23.974V	2mV	0.008%
125A	23.982V	23.981V	23.981V	23.982V	1mV	0.004%
Load regulation	145mV	144mV	147mV	144mV		
	0.604%	0.600%	0.612%	0.600%		

2. Temperature drift

Conditions Vin : 100 VAC

Iout : 62.5 A

Ta	-20°C	+25°C	+50°C	Temperature stability	
Vout	23.992V	23.977V	23.950V	42mV	0.175%

Conditions Vin : 200 VAC

Iout : 125 A

Ta	-20°C	+25°C	+50°C	Temperature stability	
Vout	23.992V	23.981V	23.952V	40mV	0.167%

(2) リプルノイズ電圧対出力電流 Ripple noise voltage vs. Output current

Conditions Vin : 100 VAC
 Vout : 24 V
 Ta : -20 °C ---
 25 °C -.-
 50 °C —

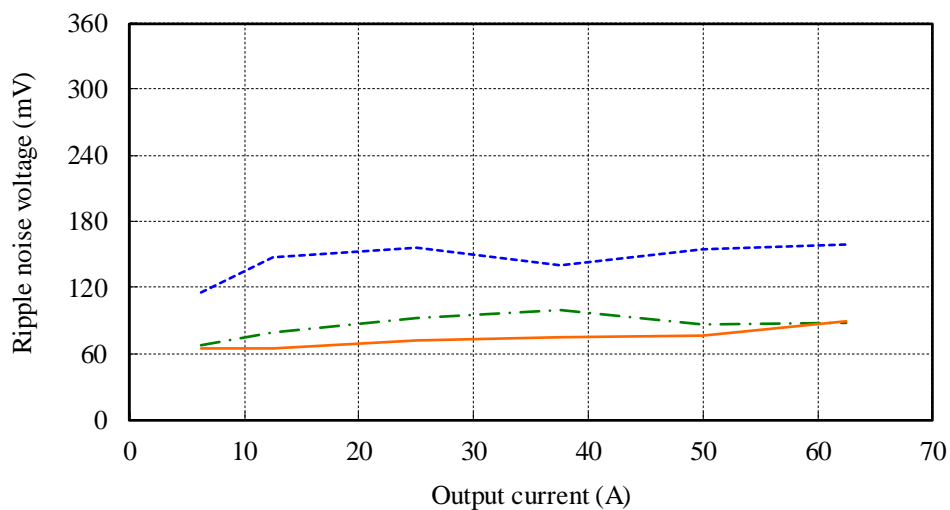

Conditions Vin : 200 VAC
 Vout : 24 V
 Ta : -20 °C ---
 25 °C -.-
 50 °C —

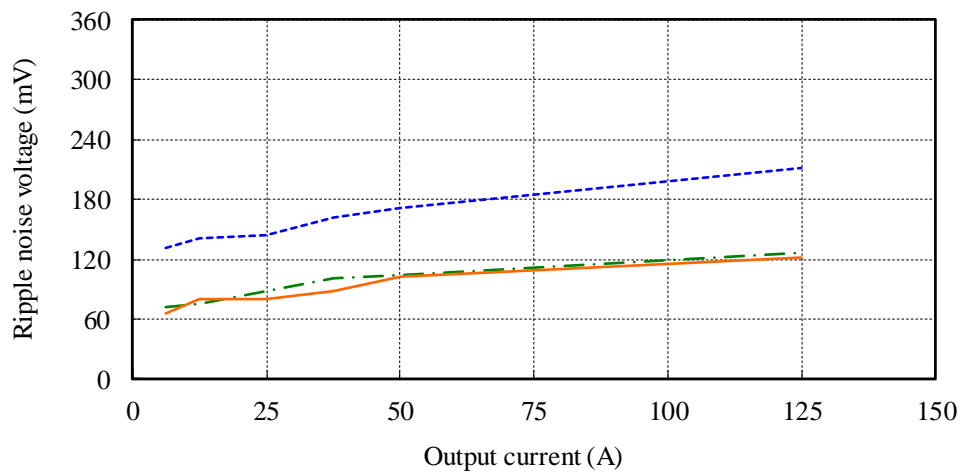

(3) 効率・力率対出力電流 Efficiency and Power factor vs. Output current

Conditions Vin : 100 VAC ---
 115 VAC -.-
 Vout : 24 V
 Iaux : 0 %
 Ta : 25 °C

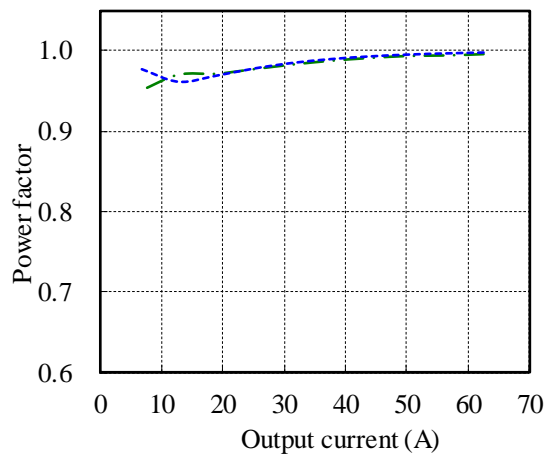
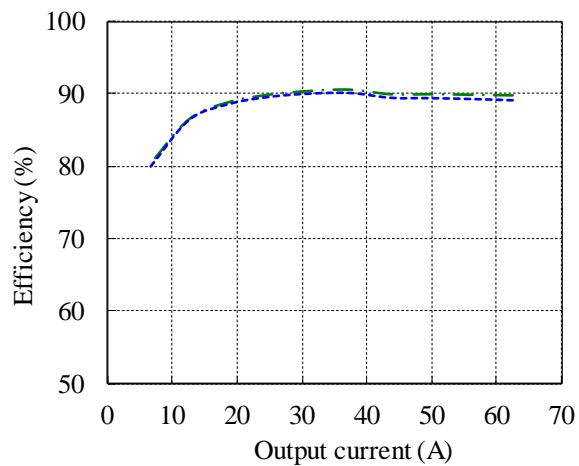

Conditions Vin : 200 VAC ---
 230 VAC -.-
 Vout : 24 V
 Iaux : 0 %
 Ta : 25 °C

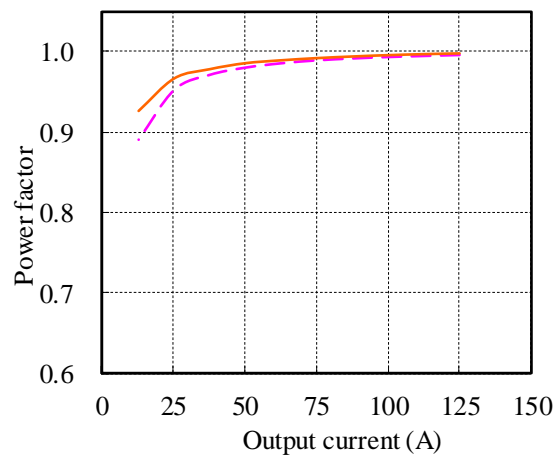
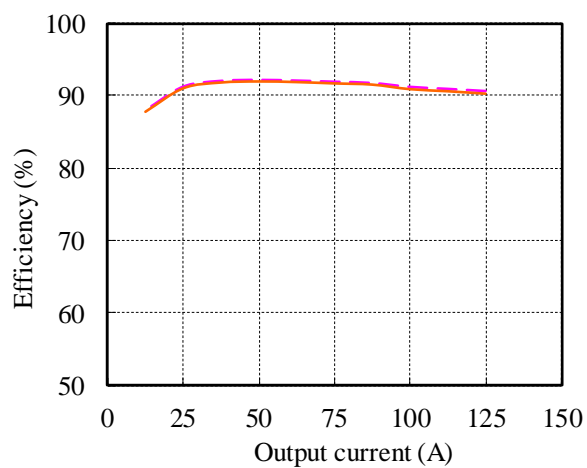

(4) 入力電力対出力電流 Input power vs. Output current

Vin	Input power	
	Iout : 0%	Control OFF
100VAC	11.2W	8.5W
115VAC	10.3W	8.0W

Conditions Vin : 100 VAC ---
 115 VAC -.-
 Vout : 24 V
 Iaux : 0 %
 Ta : 25 °C

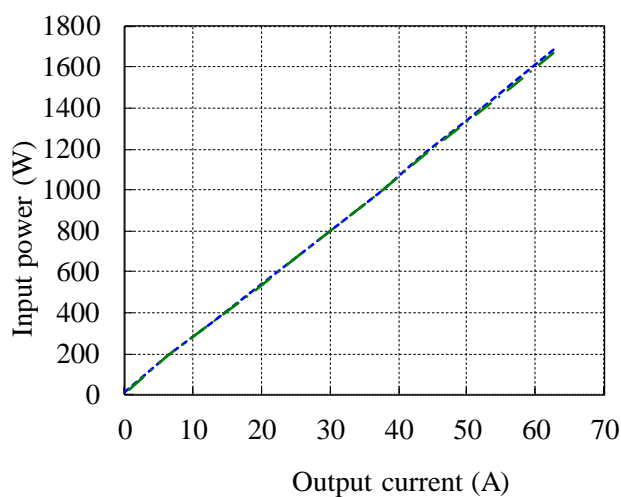

Vin	Input power	
	Iout : 0%	Control OFF
200VAC	9.1W	7.0W
230VAC	9.0W	7.0W

Conditions Vin : 200 VAC —
 230 VAC -.-
 Vout : 24 V
 Iaux : 0 %
 Ta : 25 °C

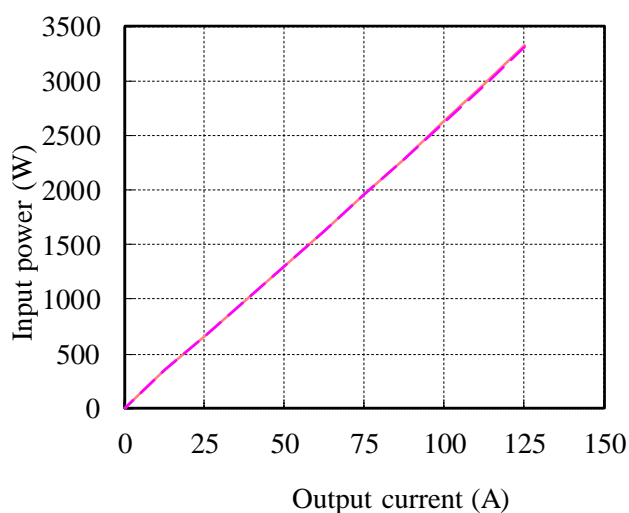

(5) 入力電流対出力電流 Input current vs. Output current

Vin	Input current	
	Iout : 0%	Control OFF
100VAC	0.23A	0.19A
115VAC	0.21A	0.18A

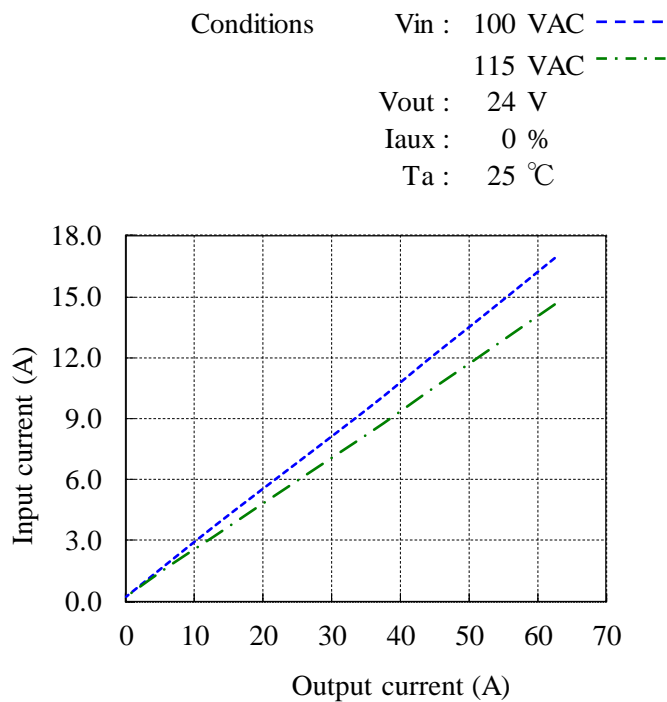

Vin	Input current	
	Iout : 0%	Control OFF
200VAC	0.24A	0.22A
230VAC	0.26A	0.25A

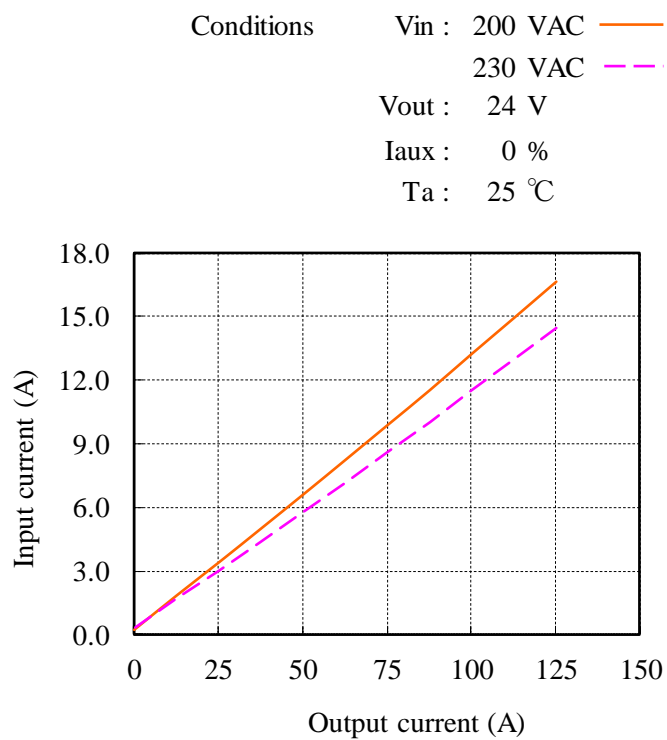

2-1-2. 通電ドリフト特性 Warm up voltage drift characteristics

Conditions Vin : 100 VAC
 Vout : 24 V
 Iout : 62.5 A
 Ta : 25 °C

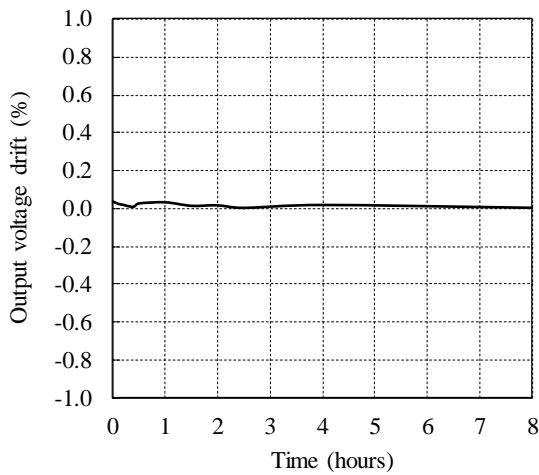

Conditions Vin : 200 VAC
 Vout : 24 V
 Iout : 125 A
 Ta : 25 °C

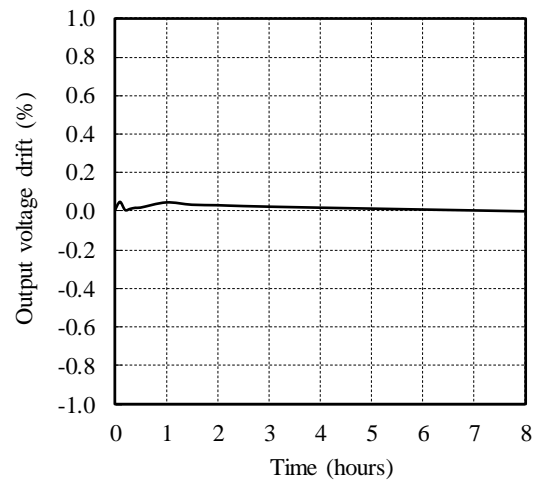

2-1-3. 出力保持時間特性 Hold up time characteristics

Conditions Vin : 100 VAC
 Vout : 24 V
 Ta : 25 °C

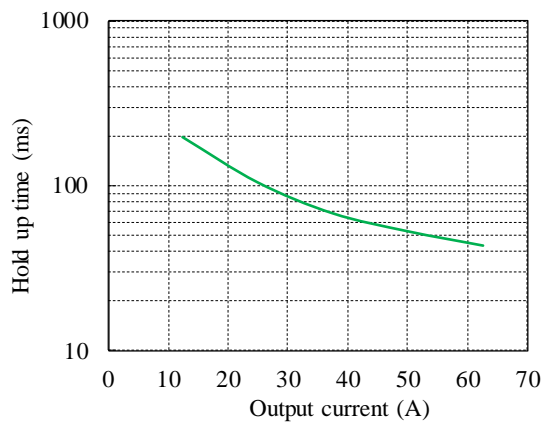

Conditions Vin : 200 VAC
 Vout : 24 V
 Ta : 25 °C

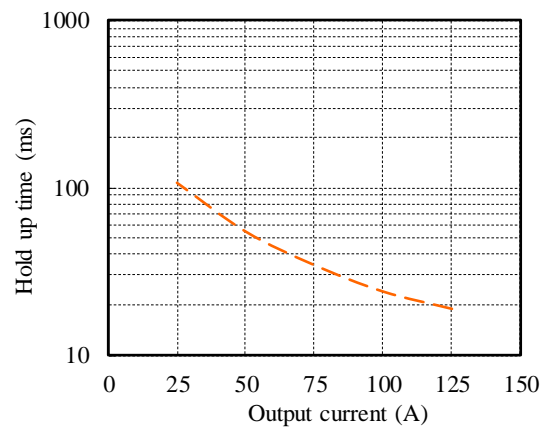

2-1-4. 出力電圧立ち上がり特性 Output voltage rise characteristics

Conditions Vin : 100 VAC (A)
 115 VAC (B)
 Iaux : 100 %
 Ta : 25 °C

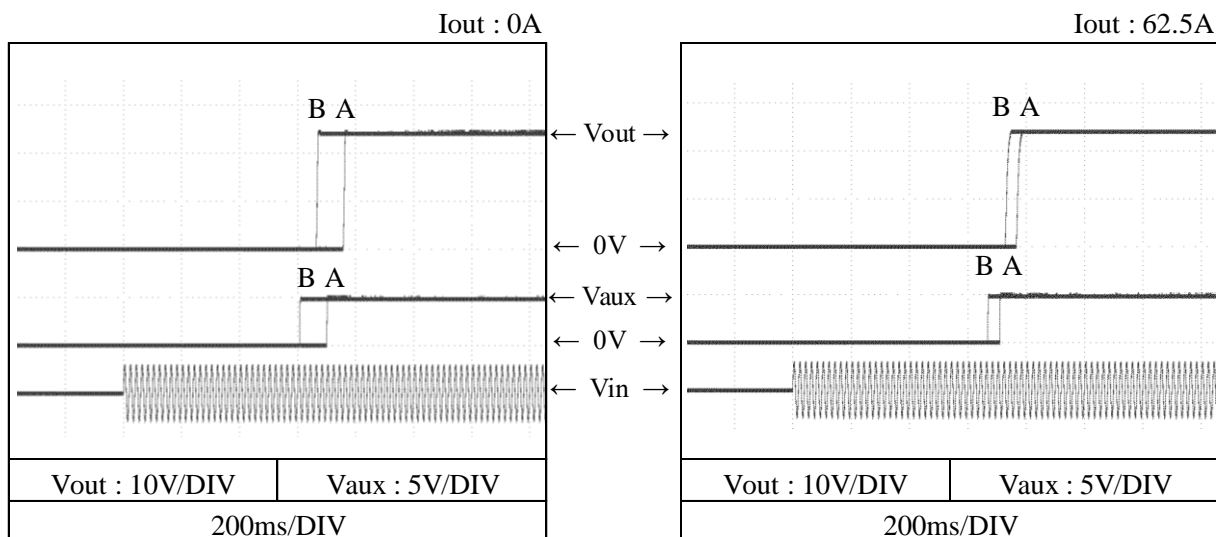

Conditions Vin : 200 VAC (C)
 230 VAC (D)
 Iaux : 100 %
 Ta : 25 °C

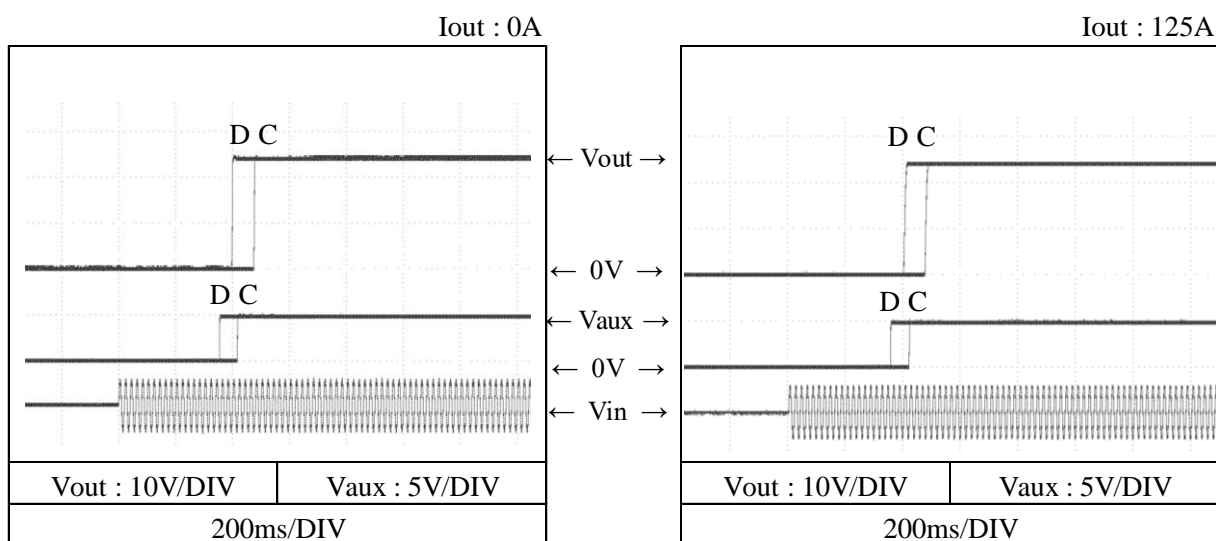

2-1-5. 出力電圧立ち下がり特性 Output voltage fall characteristics

Conditions Vin : 100 VAC (A)
 115 VAC (B)
 Iaux : 100 %
 Ta : 25 °C

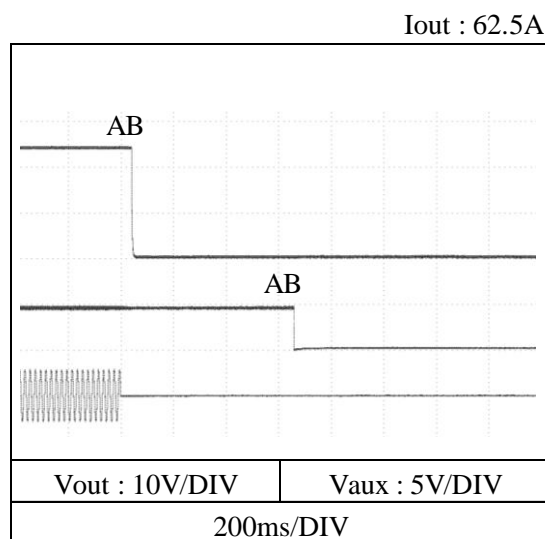
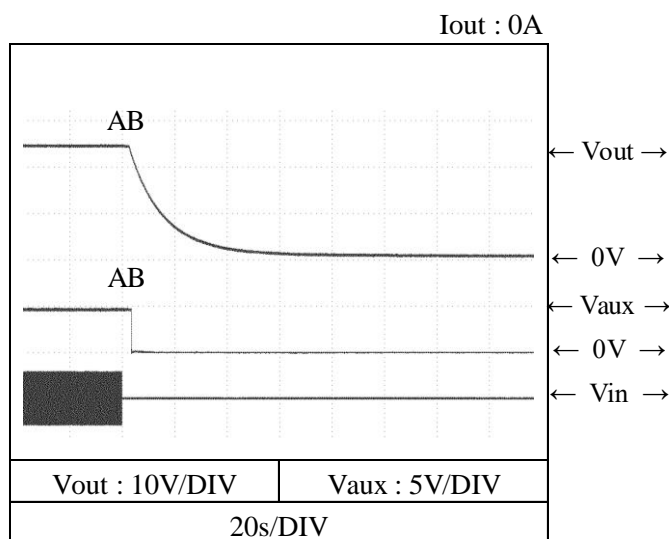

Conditions Vin : 200 VAC (C)
 230 VAC (D)
 Iaux : 100 %
 Ta : 25 °C

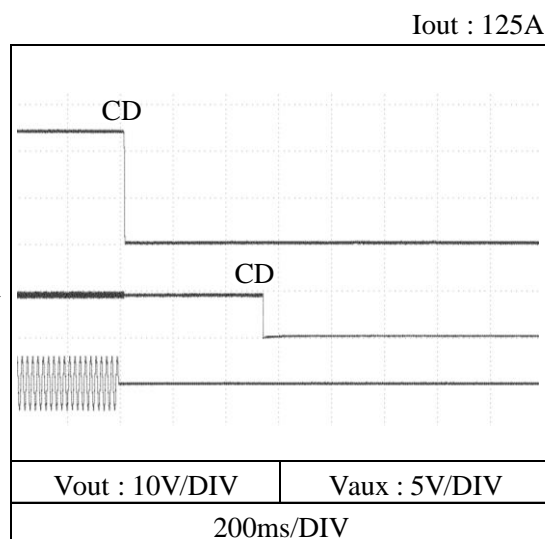
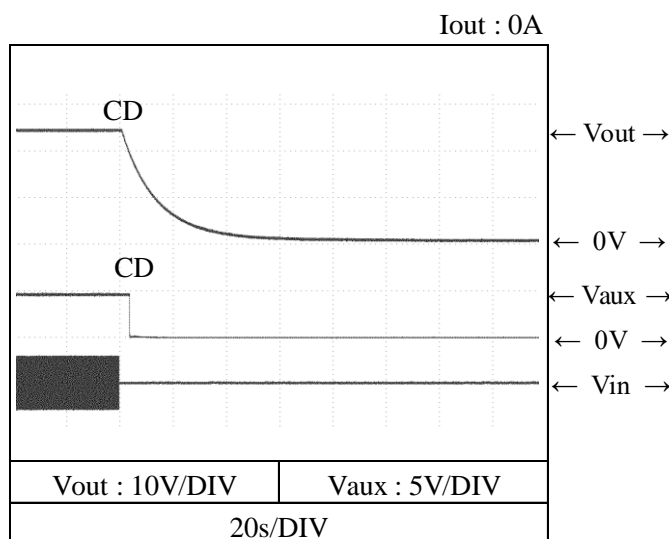

2-1-6. ON/OFFコントロール時出力立ち上がり、立ち下がり特性

Output rise, fall characteristics with ON/OFF Control

(a) リモートON/OFFコントロール端子によるON/OFF

ON/OFF control by remote ON/OFF control terminal

Conditions V_{in} : 100 VAC

T_a : 25 °C

I_{out} : 0A

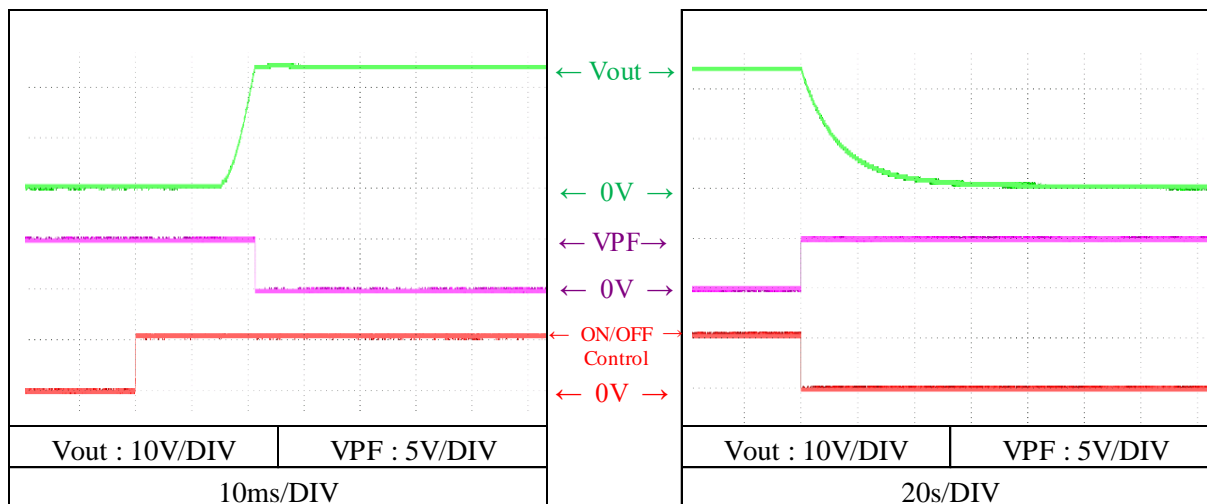

I_{out} : 62.5A

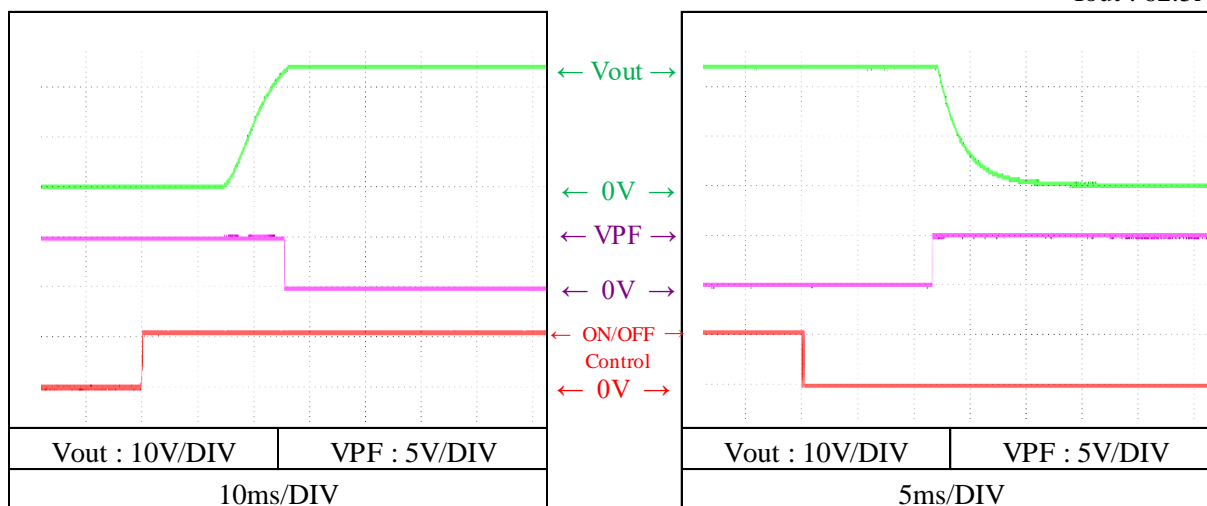

(a) リモートON/OFFコントロール端子によるON/OFF

ON/OFF control by remote ON/OFF control terminal

Conditions Vin : 200 VAC

Ta : 25 °C

Iout : 0A

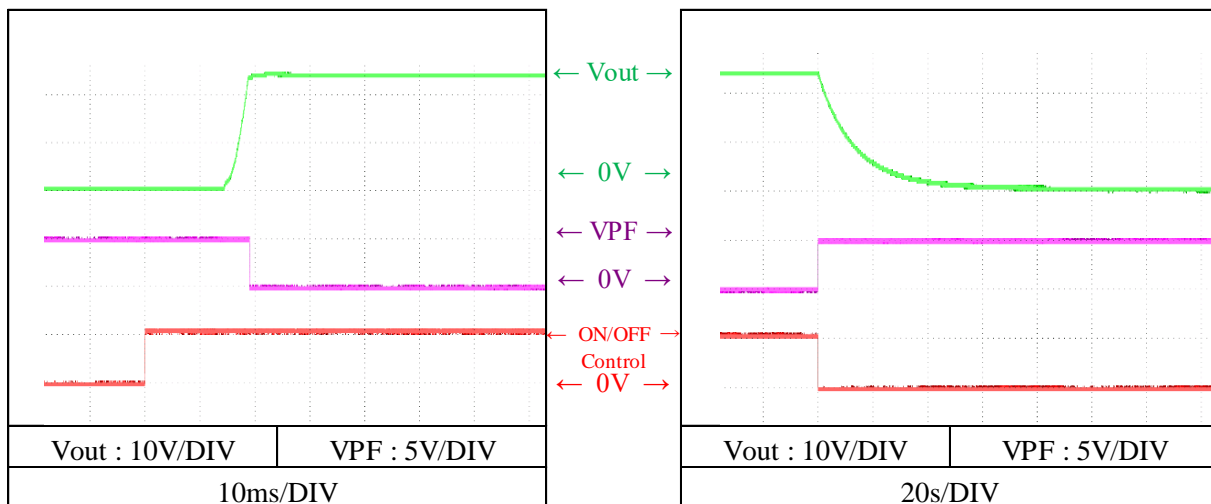

Iout : 125A

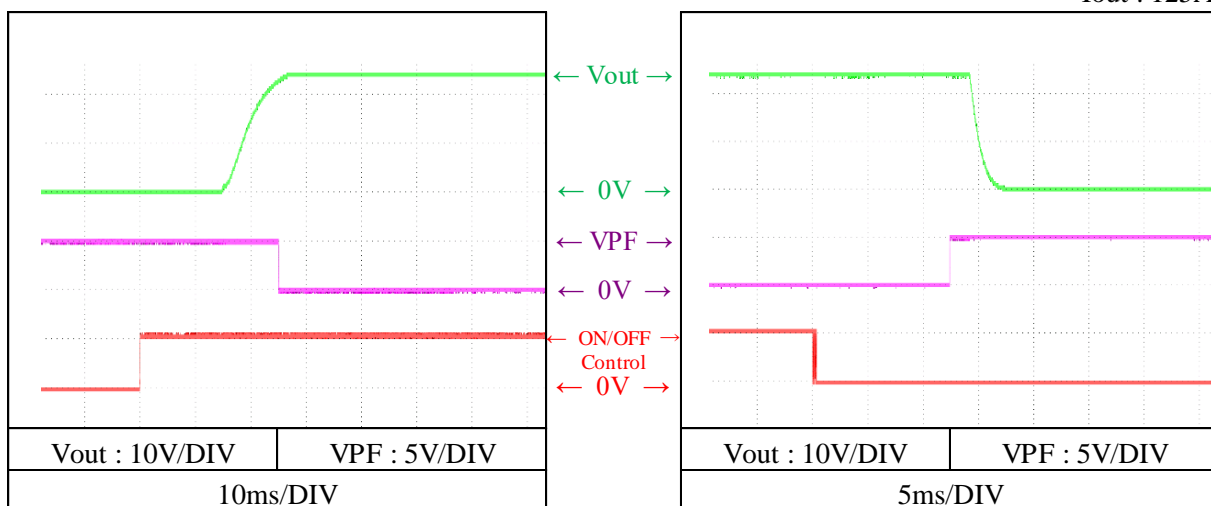

2-1-6. ON/OFFコントロール時出力立ち上がり、立ち下がり特性

Output rise, fall characteristics with ON/OFF Control

(b) RS-485通信によるON/OFF ON/OFF control by RS-485

Conditions Vin : 100 VAC

Ta : 25 °C

Iout : 0A

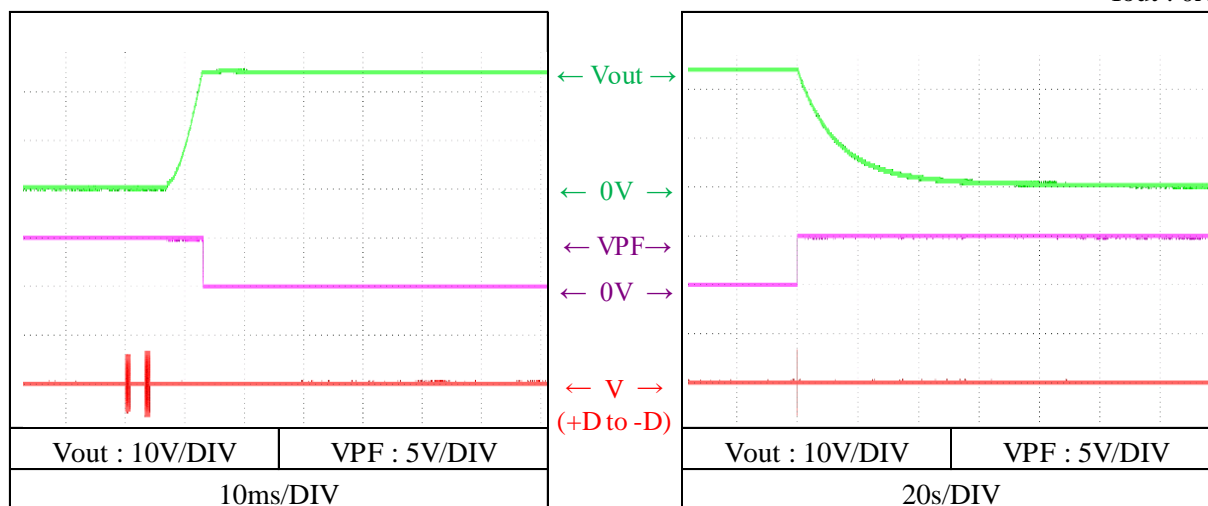

Iout : 62.5A

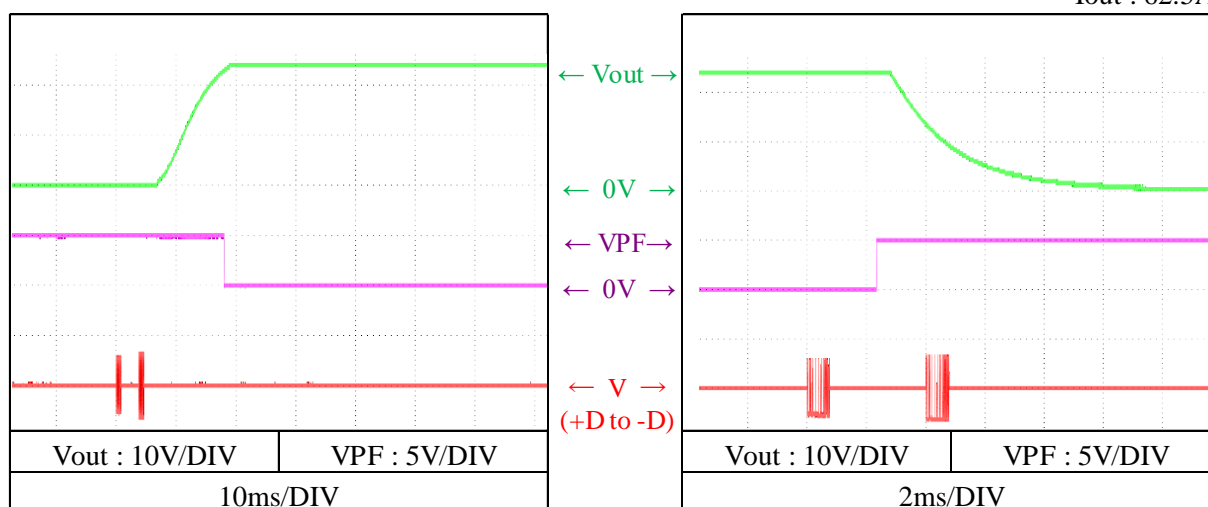

(b) RS-485通信によるON/OFF ON/OFF control by RS-485

Conditions V_{in} : 200 VAC

T_a : 25 °C

I_{out} : 0A

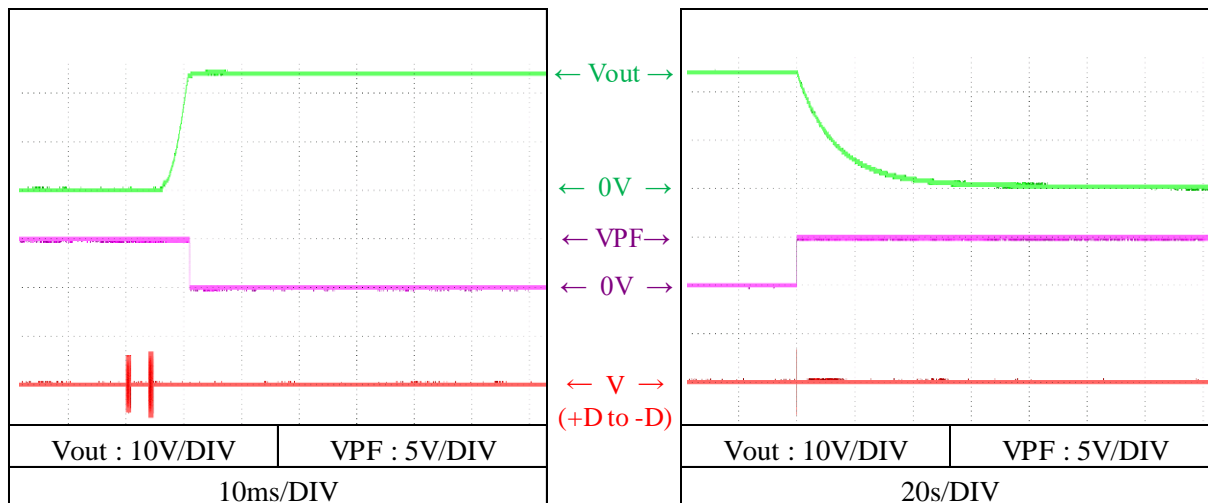

I_{out} : 125A

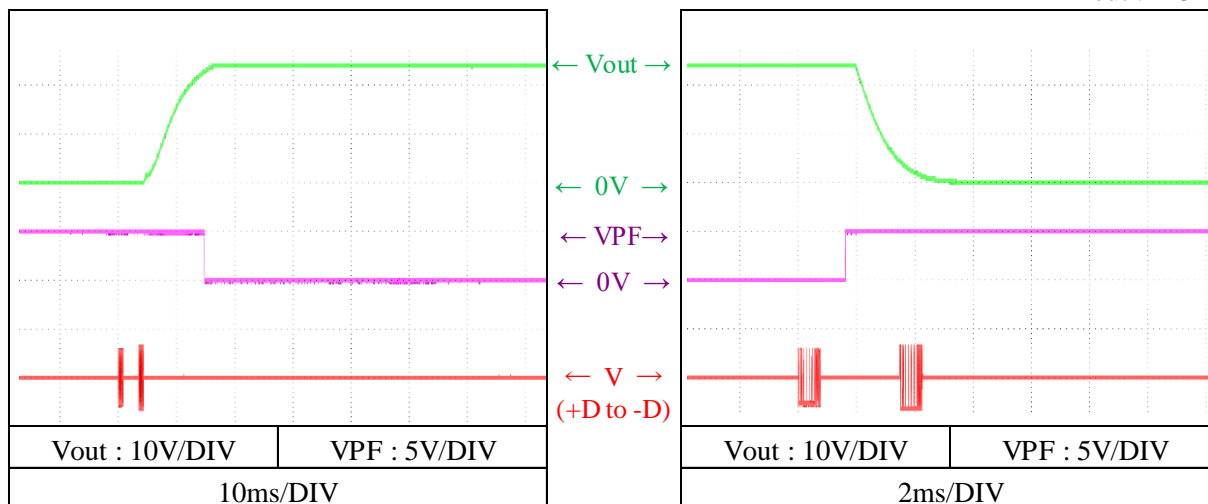

2-1-7. 過渡応答 (負荷急変) 特性 Dynamic load response characteristics

Conditions V_{in} : 100 VAC
 I_{out} : 31.25A \leftrightarrow 62.5A
 (tr = tf = 50us)
 T_a : 25 °C

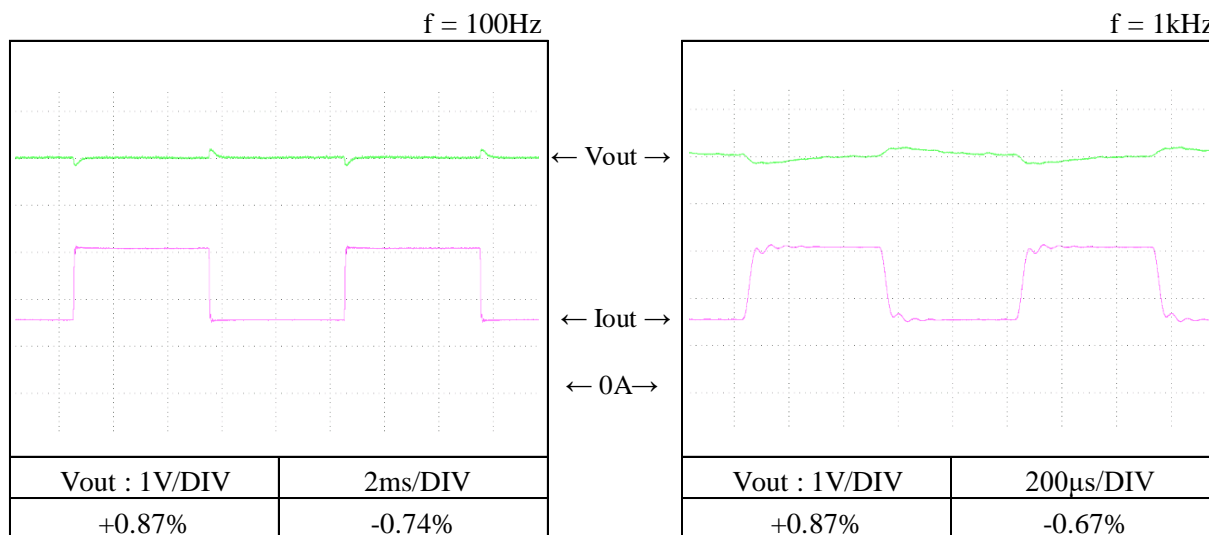

Conditions V_{in} : 200 VAC
 I_{out} : 62.5A \leftrightarrow 125A
 (tr = tf = 50us)
 T_a : 25 °C

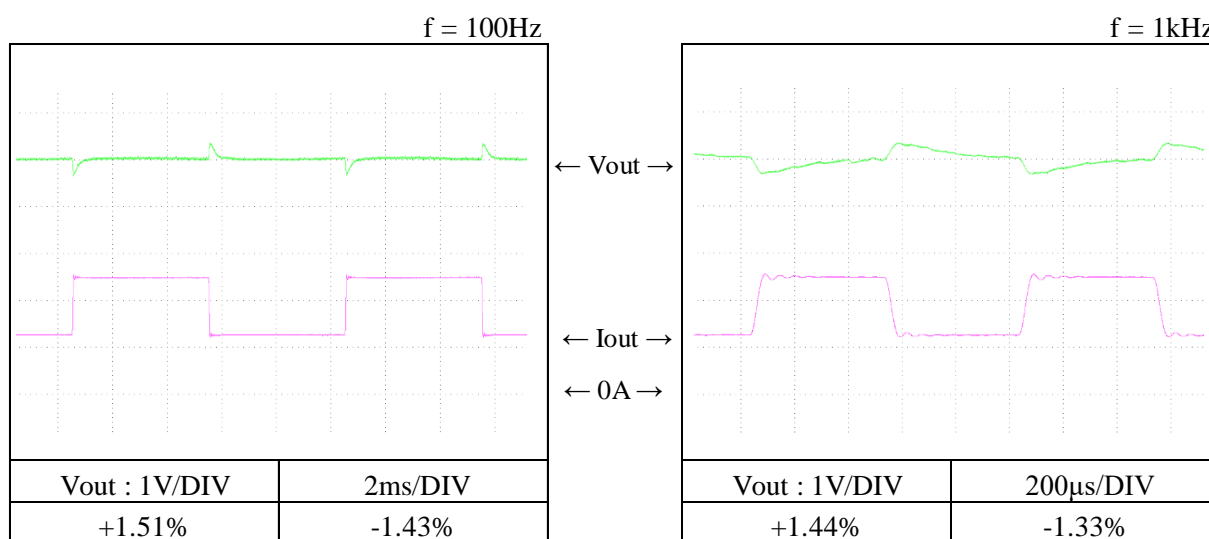

2-1-8. 入力電圧瞬停特性 Response to brown out characteristics

瞬停時間 Interruption time

A : 出力電圧の低下なし Output voltage does not drop.

B : 出力電圧の低下が0Vまでいかない Output voltage drop down not reaching 0V.

C : 出力電圧が0Vまで低下 Output voltage drops until 0V.

Conditions V_{in} : 100VAC

I_{out} : 62.5 A

T_a : 25 °C

Conditions V_{in} : 200VAC

I_{out} : 125 A

T_a : 25 °C

A = 16ms, C = 17ms

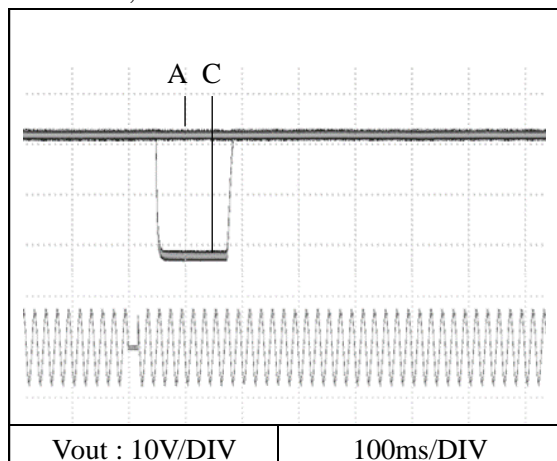

A = 8ms, C = 9ms

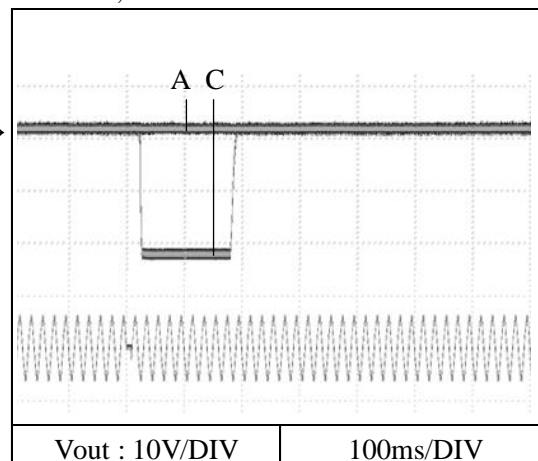

2-1-9. 出力リップル、ノイズ波形 Output ripple and noise waveform

Conditions V_{in} : 100VAC

V_{out} : 24 V

I_{out} : 62.5 A

T_a : 25 °C

Conditions V_{in} : 200VAC

V_{out} : 24 V

I_{out} : 125 A

T_a : 25 °C

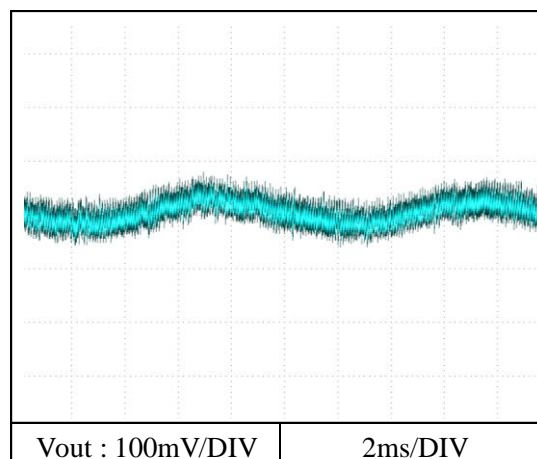
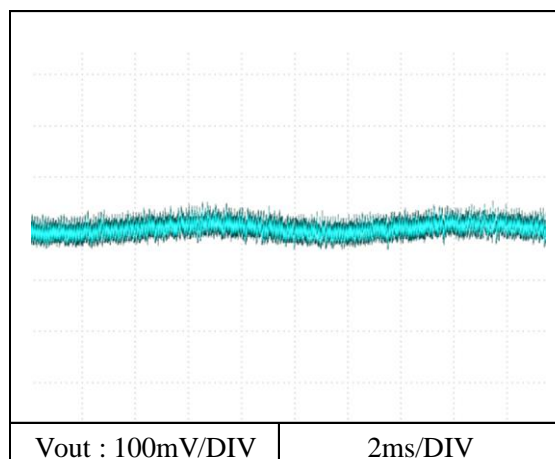

2-2. 定電流出力モード Constant current output mode

2-2-1. 静特性 Steady state data

(1) 入力・負荷・温度変動 Regulation - line and load, Temperature drift

1. Regulation - line and load

Condition Ta : 25 °C

Vout \ Vin	85VAC	100VAC	115VAC	132VAC	Line regulation	
2.4V	62.55A	62.55A	62.55A	62.56A	8mA	0.013%
12V	62.51A	62.51A	62.51A	62.51A	2mA	0.003%
24V	62.57A	62.55A	62.55A	62.56A	6mA	0.010%
Load regulation	58mA	42mA	40mA	45mA		
	0.093%	0.067%	0.064%	0.072%		

Vout \ Vin	170VAC	200VAC	230VAC	265VAC	Line regulation	
2.4V	125.32A	125.30A	125.30A	125.30A	21mA	0.017%
12V	125.22A	125.24A	125.25A	125.23A	35mA	0.028%
24V	125.27A	125.27A	125.29A	125.28A	20mA	0.016%
Load regulation	100mA	58mA	44mA	68mA		
	0.080%	0.046%	0.035%	0.054%		

2. Temperature drift

Conditions Vin : 100 VAC

Vout : 24 V

Ta	-20°C	+25°C	+50°C	Temperature stability	
Iout	62.54A	62.55A	62.60A	64mA	0.102%

Conditions Vin : 200 VAC

Vout : 24 V

Ta	-20°C	+25°C	+50°C	Temperature stability	
Iout	125.00A	125.27A	125.39A	391mA	0.313%

(2) リップルノイズ電流対出力電圧 Ripple noise current vs. Output voltage

Conditions
 Vin : 100 VAC
 Iout : 62.5 A
 Ta : -20 °C ---
 25 °C -.-
 50 °C —

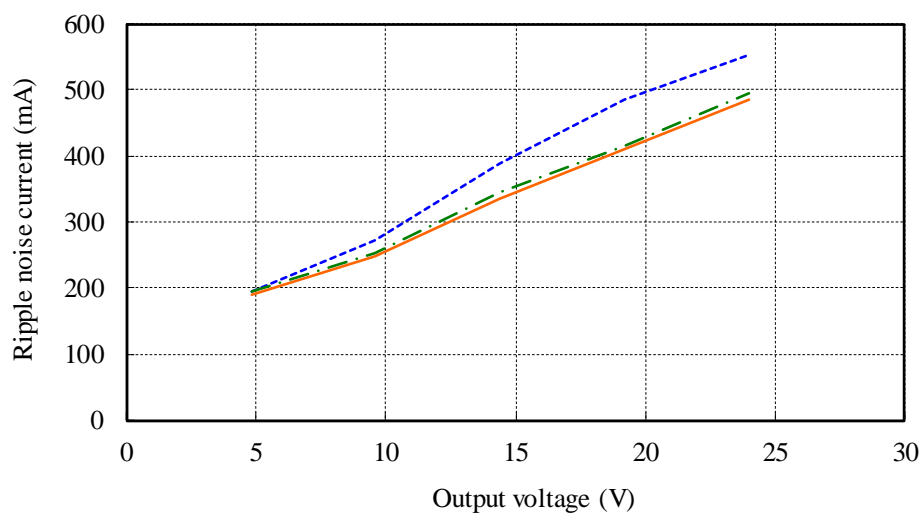

Conditions
 Vin : 200 VAC
 Iout : 125 A
 Ta : -20 °C ---
 25 °C -.-
 50 °C —

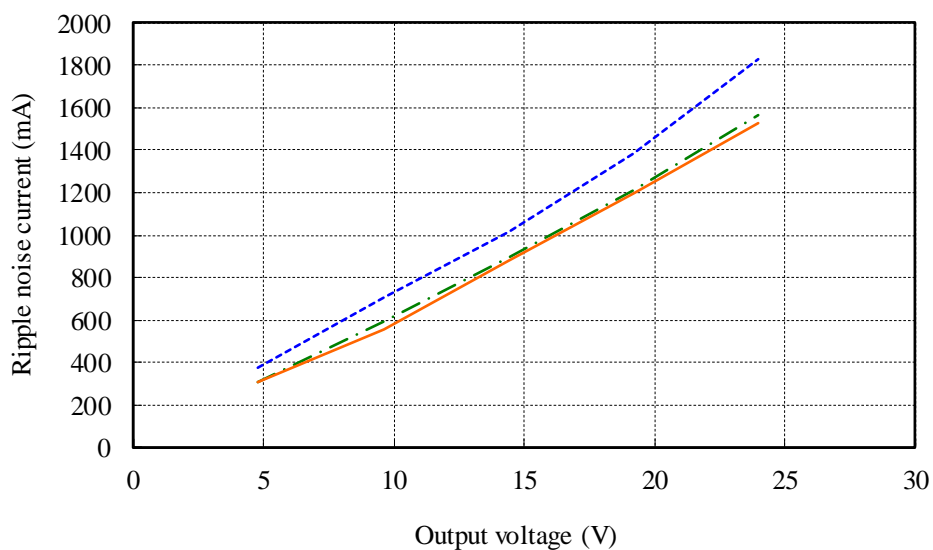

(3) 効率・力率対出力電圧 Efficiency and Power factor vs. Output voltage

Conditions Vin : 100 VAC ---
 115 VAC -.-
 Iout : 62.5 A
 Iaux : 0 %
 Ta : 25 °C

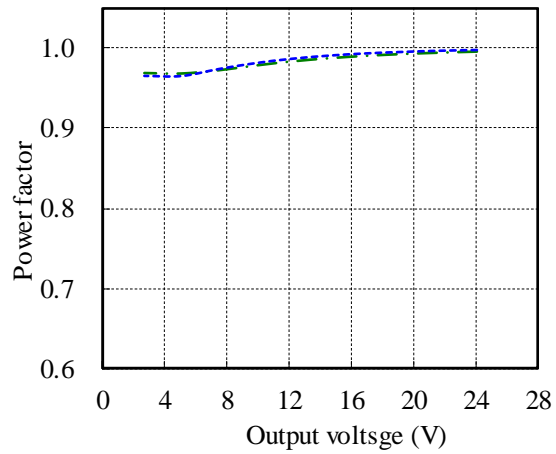
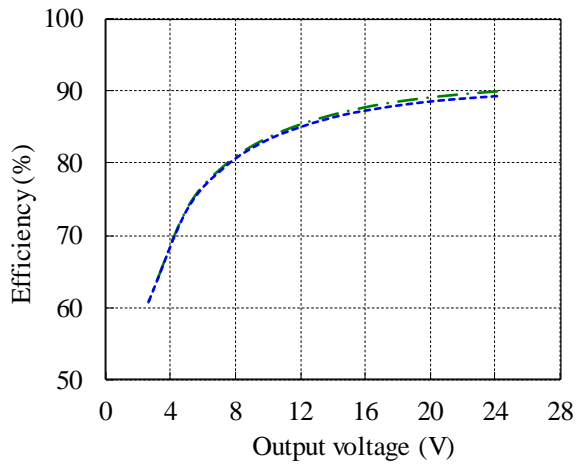

Conditions Vin : 200 VAC ---
 230 VAC -.-
 Iout : 125 A
 Iaux : 0 %
 Ta : 25 °C

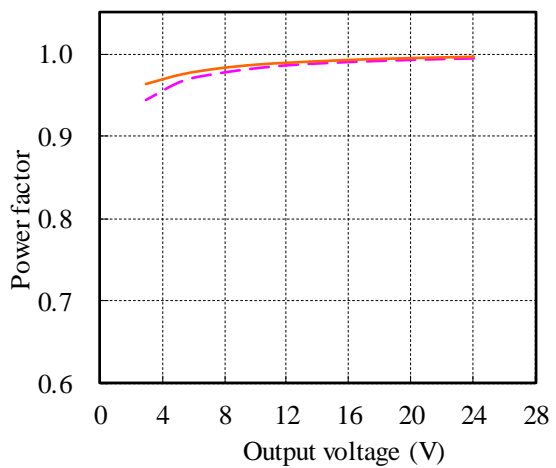
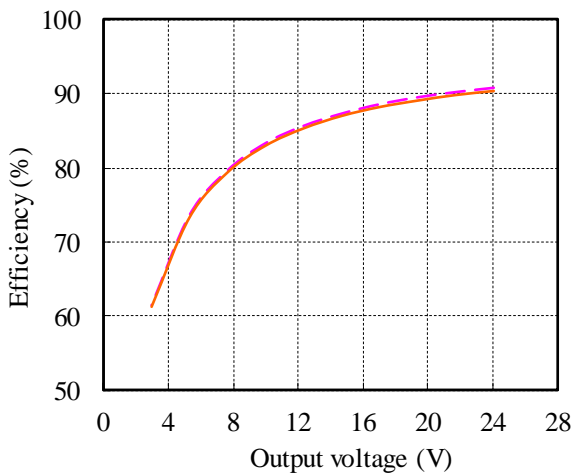

(4) 入力電力対出力電圧 Input power vs. Output voltage

Conditions Vin : 100 VAC ---
 115 VAC - - -
 Iout : 62.5 A
 Iaux : 0 %
 Ta : 25 °C

Vin	Input power
	Control OFF
100VAC	8.5W
115VAC	8.0W

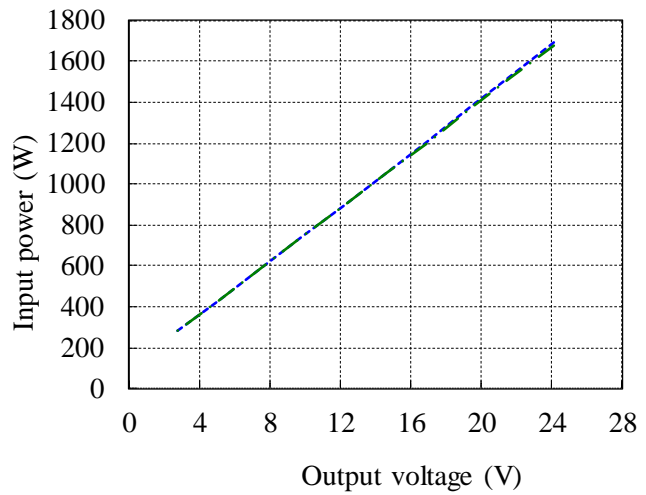

Conditions Vin : 200 VAC ---
 230 VAC - - -
 Iout : 125 A
 Iaux : 0 %
 Ta : 25 °C

Vin	Input power
	Control OFF
200VAC	7.0W
230VAC	7.0W

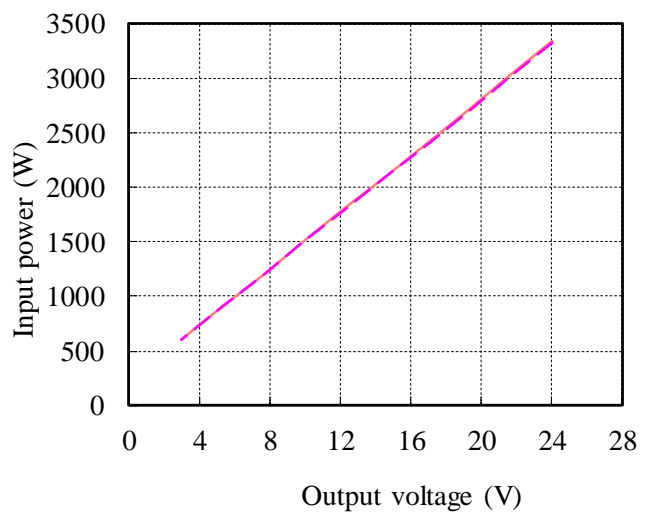

(5) 入力電流対出力電圧 Input current vs. Output voltage

Vin	Input current
	Control OFF
100VAC	0.19A
115VAC	0.18A

Conditions Vin : 100 VAC ---
 115 VAC - - -
 Iout : 62.5 A
 Iaux : 0 %
 Ta : 25 °C

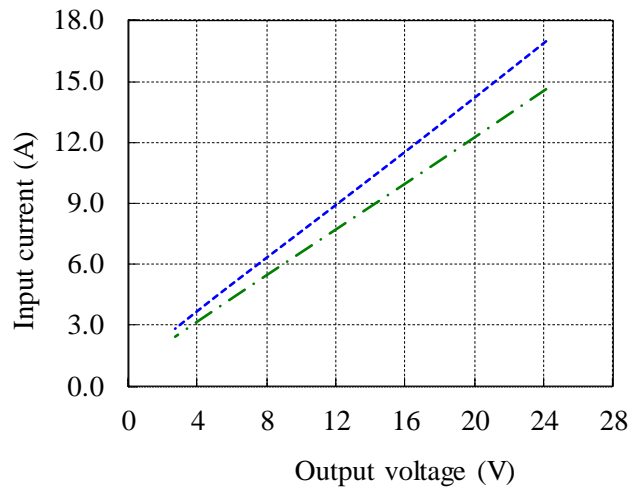

Vin	Input current
	Control OFF
200VAC	0.22A
230VAC	0.25A

Conditions Vin : 200 VAC ---
 230 VAC - - -
 Iout : 125 A
 Iaux : 0 %
 Ta : 25 °C

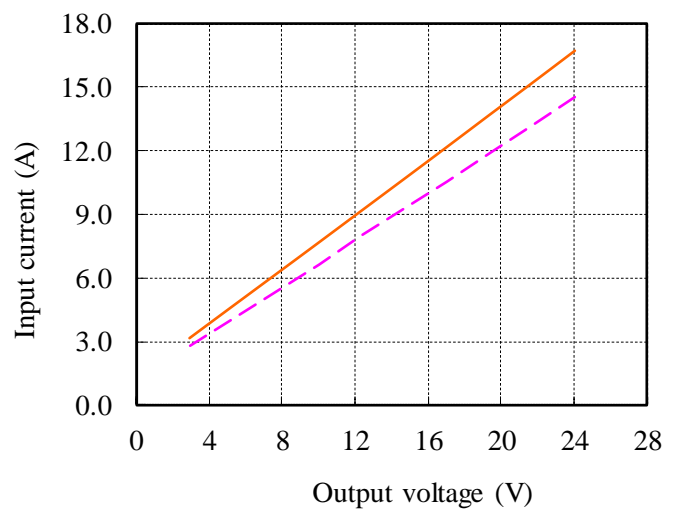

2-2-2. 通電ドリフト特性 Warm up current drift characteristics

Conditions V_{in} : 100 VAC
 V_{out} : 24 V
 I_{out} : 62.5 A
 T_a : 25 °C

Conditions V_{in} : 200 VAC
 V_{out} : 24 V
 I_{out} : 125 A
 T_a : 25 °C

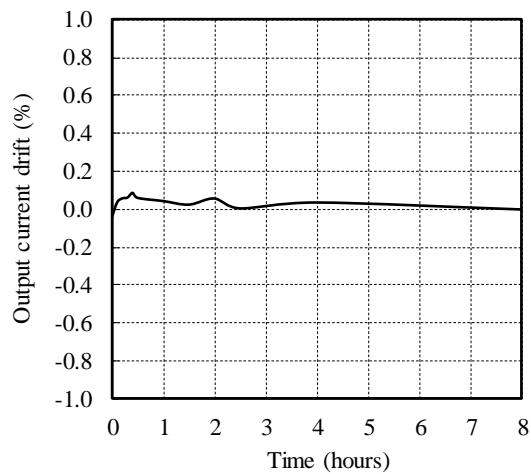
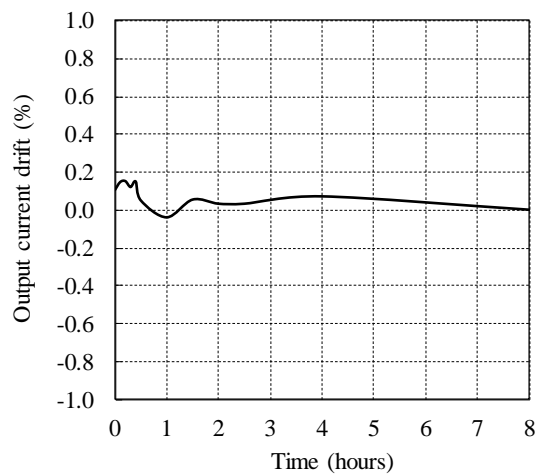

2-2-3. 出力電流立ち上がり特性 Output current rise characteristics

Conditions Vin : 100 VAC (A)

115 VAC (B)

Iaux : 100 %

Ta : 25 °C

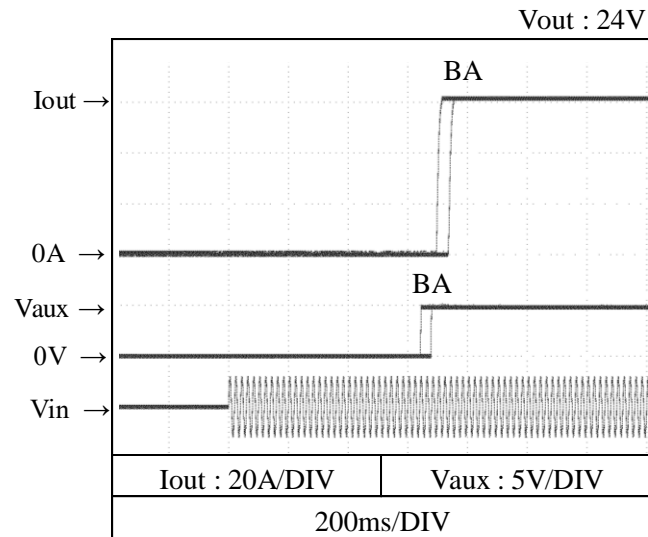

Conditions Vin : 200 VAC (C)

230 VAC (D)

Iaux : 100 %

Ta : 25 °C

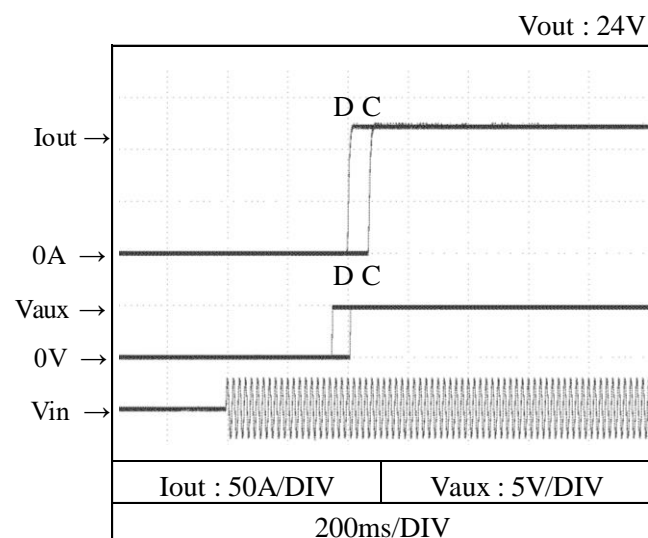

2-2-4. 出力電流立ち下がり特性 Output current fall characteristics

Conditions Vin : 100 VAC (A)

115 VAC (B)

Iaux : 100 %

Ta : 25 °C

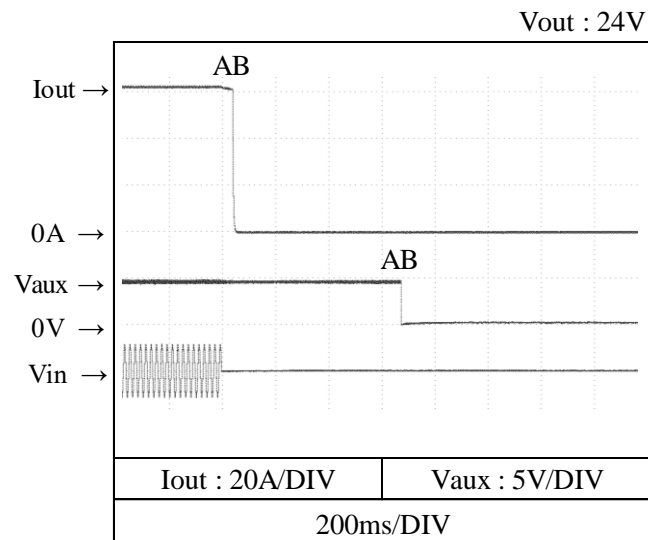

Conditions Vin : 200 VAC (C)

230 VAC (D)

Iaux : 100 %

Ta : 25 °C

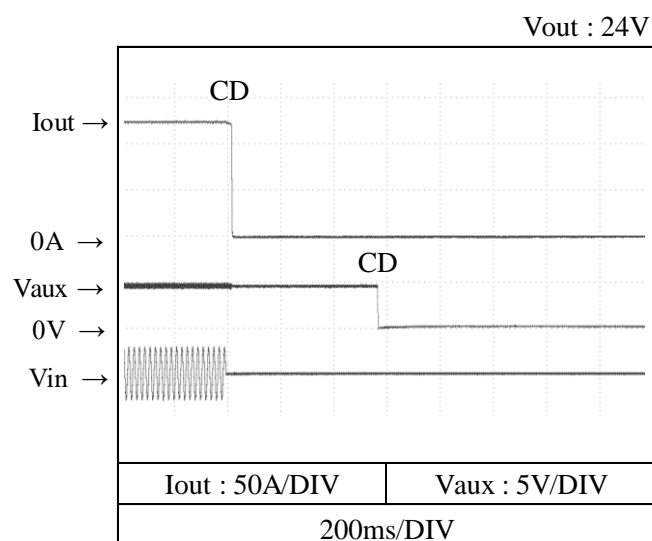

2-2-5. ON/OFFコントロール時出力立ち上がり、立ち下がり特性

Output rise, fall characteristics with ON/OFF Control

(a) リモートON/OFFコントロール端子によるON/OFF

ON/OFF control by remote ON/OFF control terminal

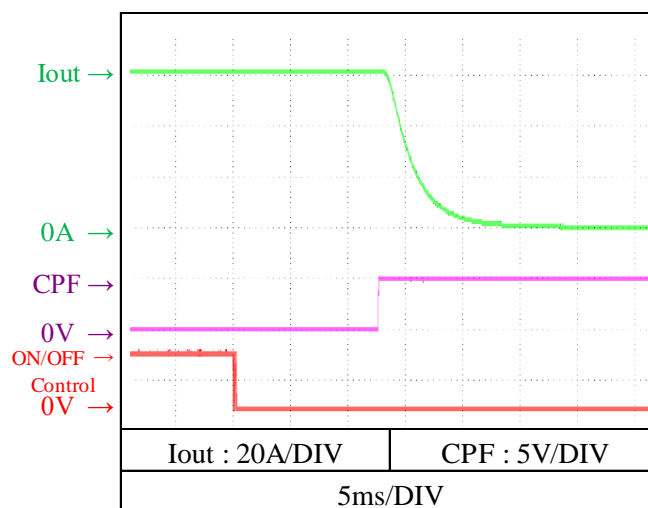
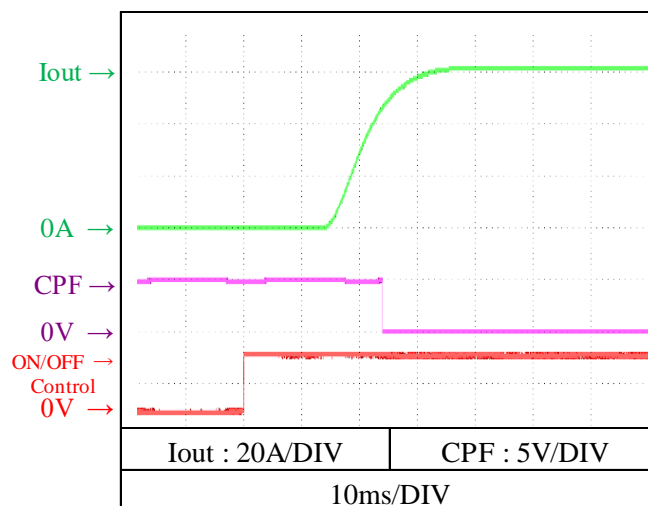
Conditions V_{in} : 100 VAC V_{out} : 24 V T_a : 25 °C

(a) リモートON/OFFコントロール端子によるON/OFF

ON/OFF control by remote ON/OFF control terminal

Conditions V_{in} : 200 VAC

V_{out} : 24 V

T_a : 25 °C

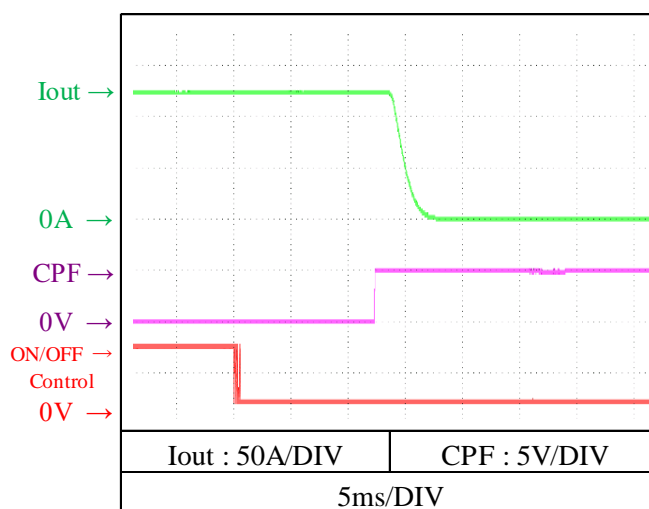
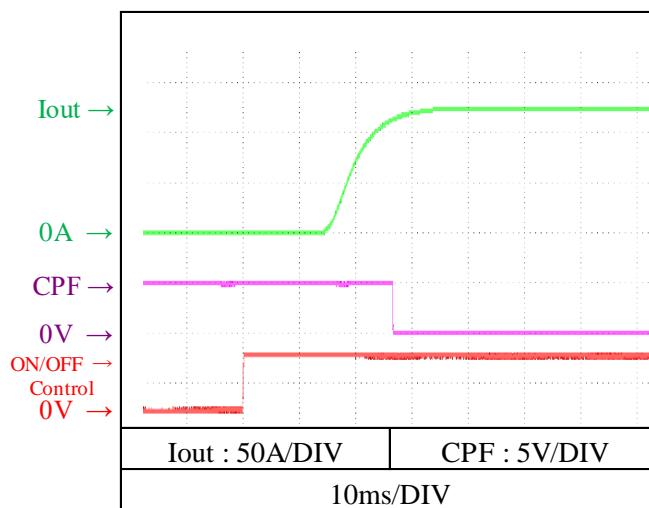

2-2-5. ON/OFFコントロール時出力立ち上がり、立ち下がり特性

Output rise, fall characteristics with ON/OFF Control

(b) RS-485通信によるON/OFF ON/OFF control by RS-485

Conditions Vin : 100 VAC

Vout : 24 V

Ta : 25 °C

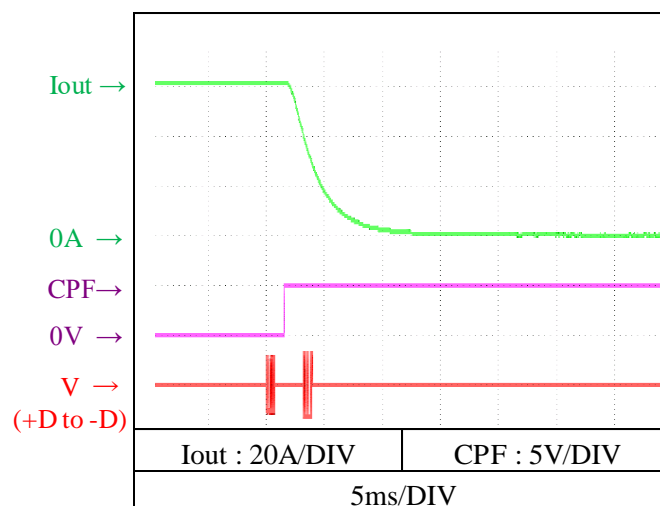
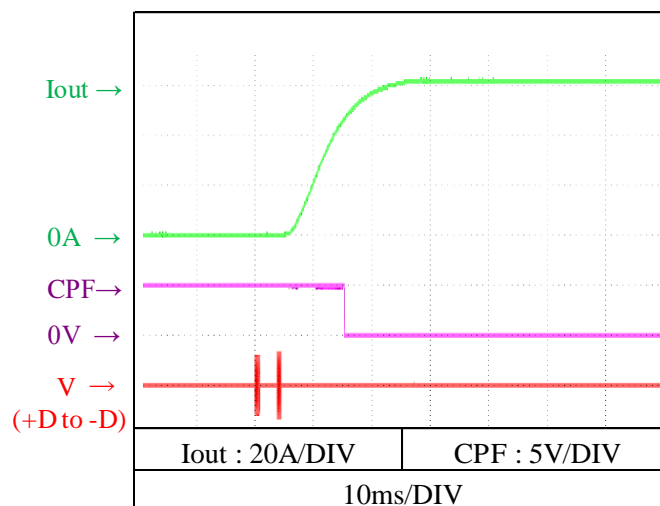

(b) RS-485通信によるON/OFF ON/OFF control by RS-485

Conditions Vin : 200 VAC

Vout : 24 V

Ta : 25 °C

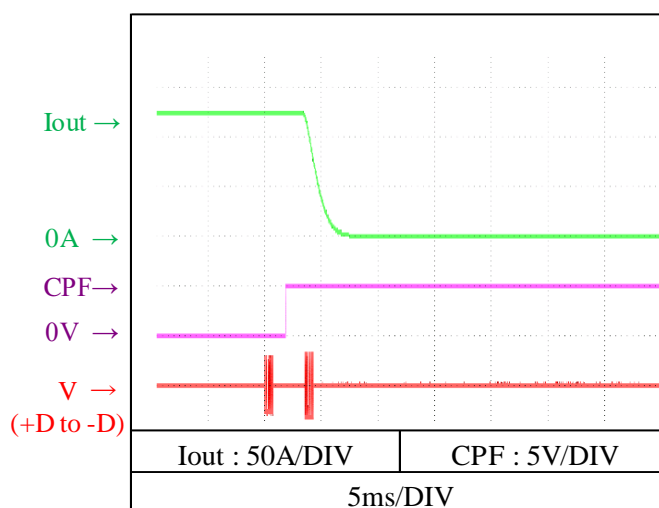
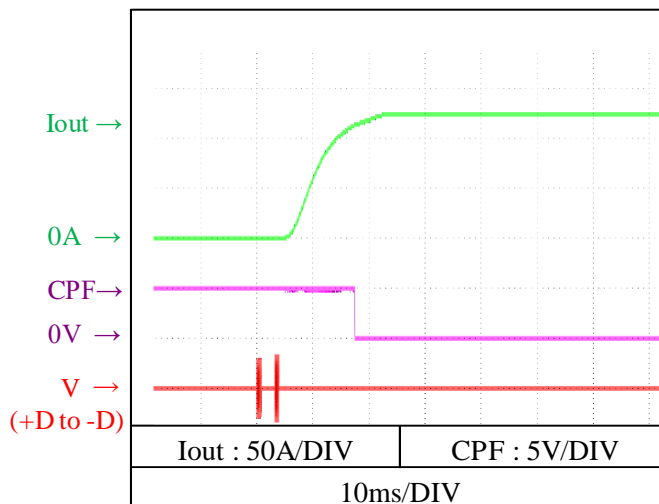

2-2-6. 入力電圧瞬停特性 Response to brown out characteristics

瞬停時間 Interruption time

A : 出力電圧の低下なし Output voltage does not drop.

B : 出力電圧の低下が0Vまでいかない Output voltage drop down not reaching 0V.

C : 出力電圧が0Vまで低下 Output voltage drops until 0V.

Conditions V_{in} : 100VAC

V_{out} : 24 V

T_a : 25 °C

Conditions V_{in} : 200VAC

V_{out} : 24 V

T_a : 25 °C

A = 16ms, C = 17ms

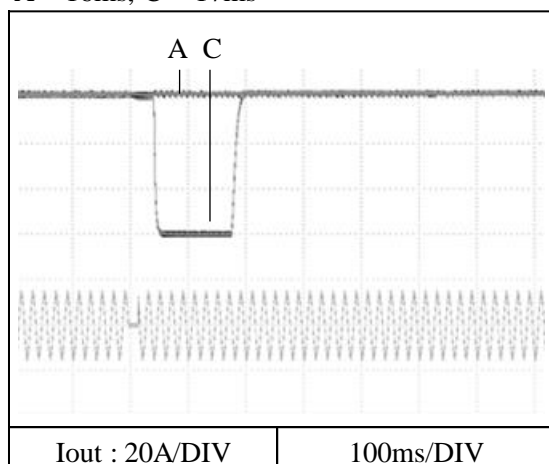

A = 9ms, C = 10ms

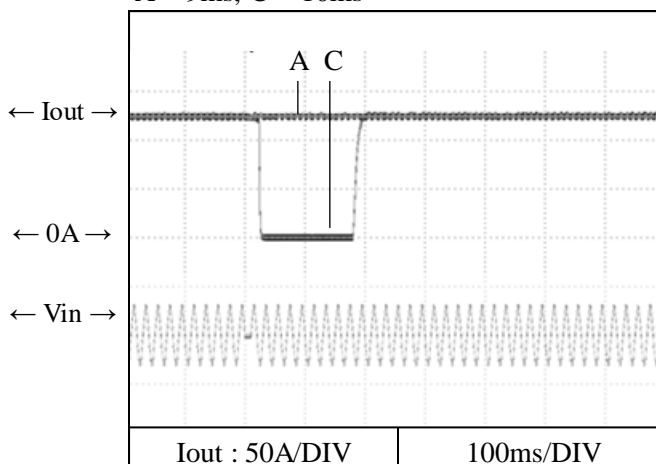

2-2-7. 出力リップル、ノイズ波形 Output ripple and noise waveform

Conditions V_{in} : 100VAC

V_{out} : 24 V

I_{out} : 62.5 A

T_a : 25 °C

Conditions V_{in} : 200VAC

V_{out} : 24 V

I_{out} : 125 A

T_a : 25 °C

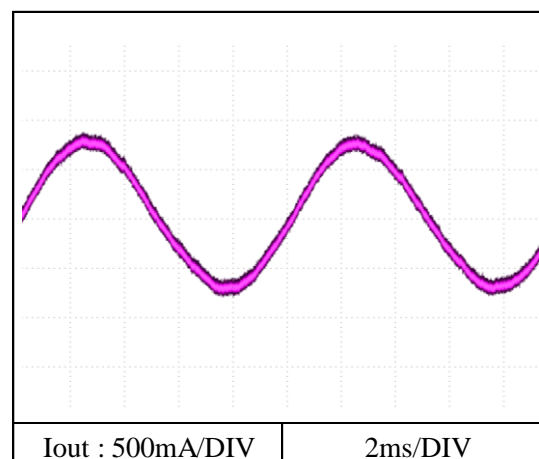
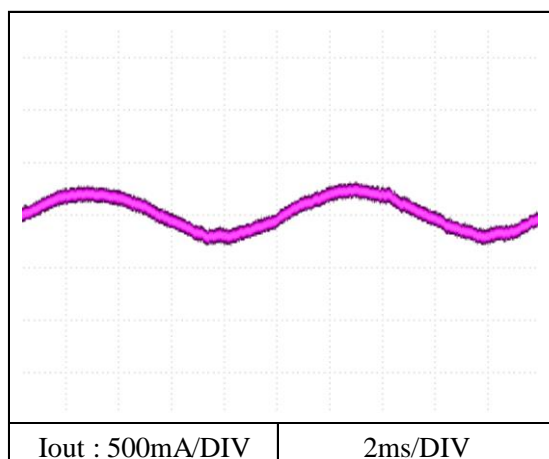

2-3. 過電流保護特性 Over current protection (OCP) characteristics

Conditions Vin : 100 VAC

Ta : -20 °C - - - -

25 °C - - - -

50 °C - - - -

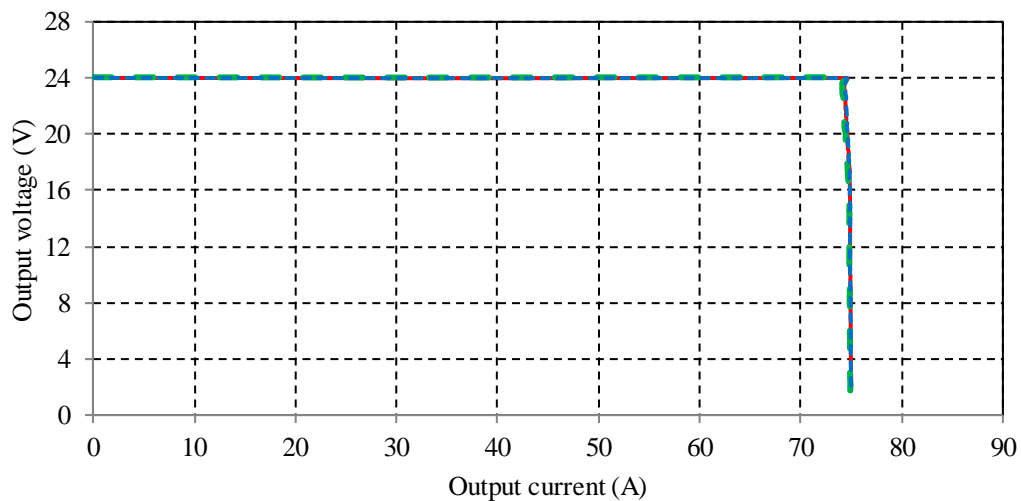

Conditions Vin : 200 VAC

Ta : -20 °C - - - -

25 °C - - - -

50 °C - - - -

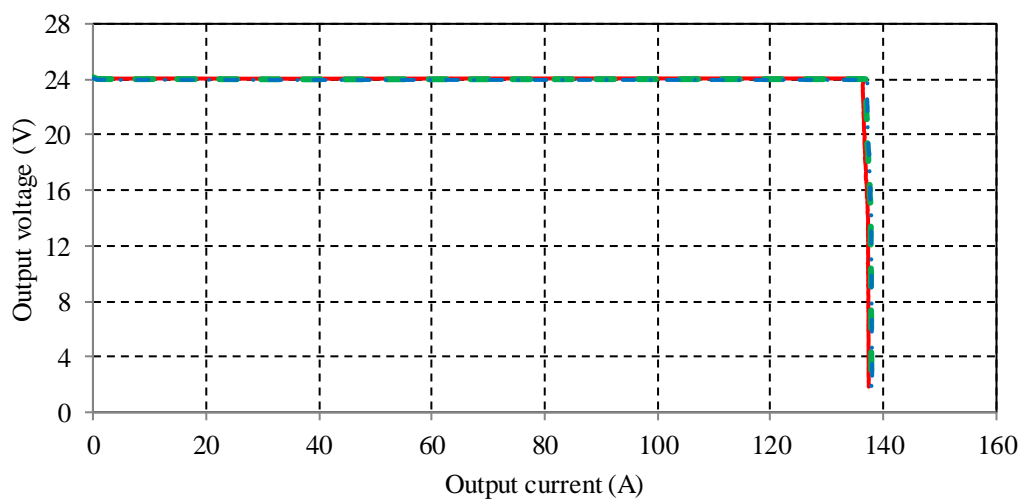

2-4. 過電圧保護特性 Over voltage protection (OVP) characteristics

Conditions V_{in} : 200VAC

I_{out} : 1 A

T_a : 25 °C

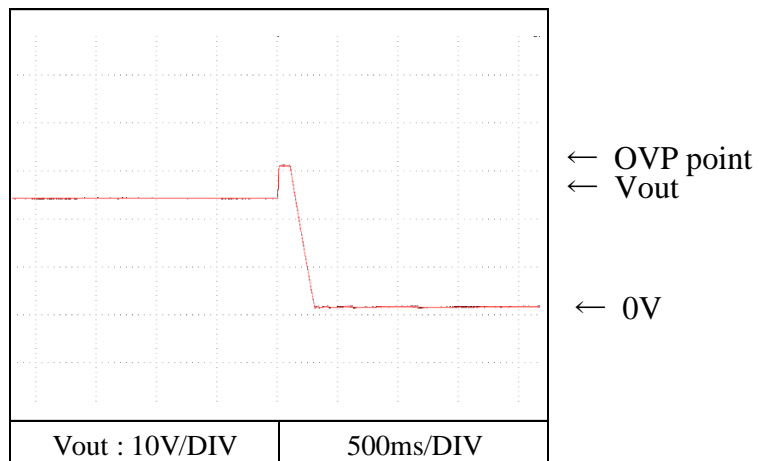

2-5. 入力サージ電流（突入電流）波形 Inrush current waveform

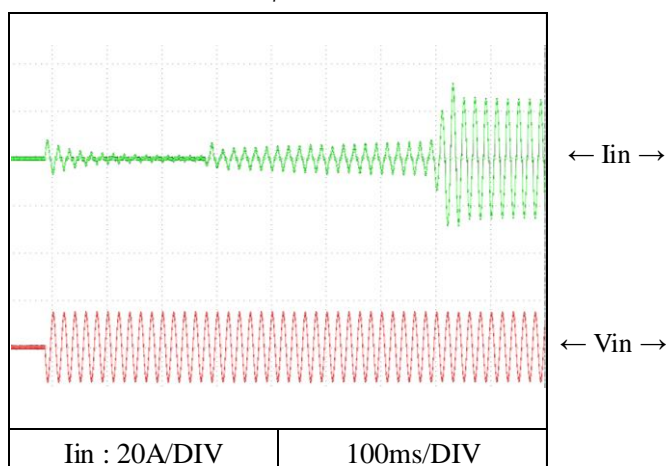
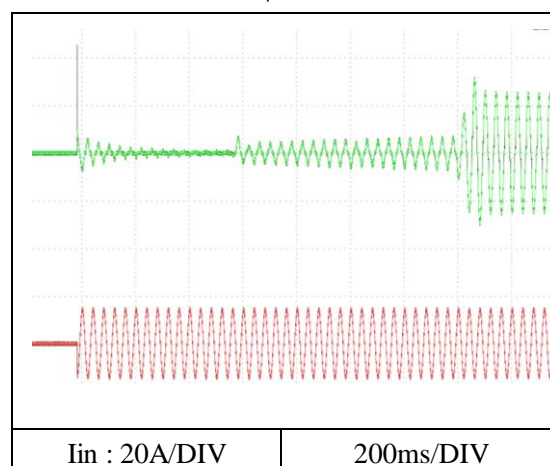
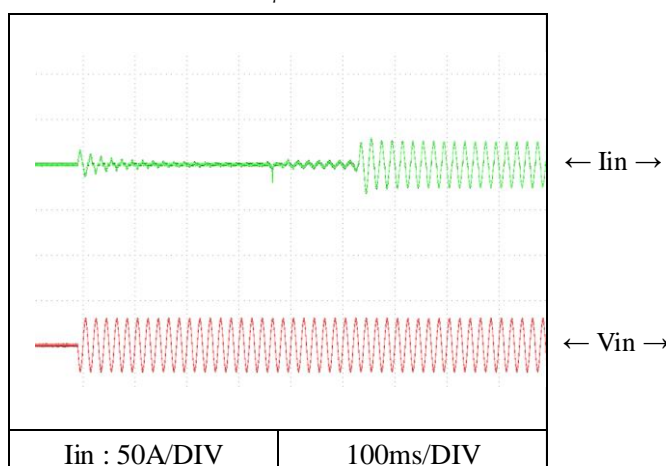
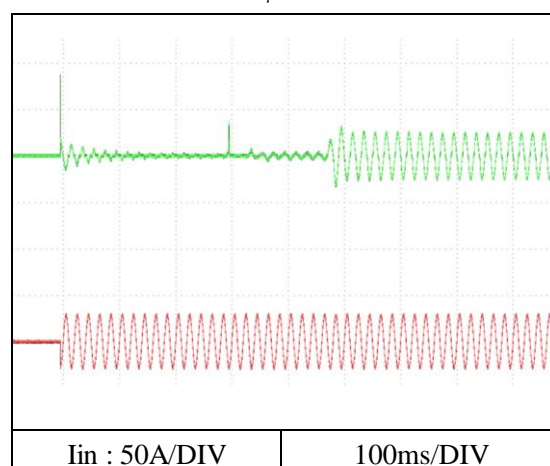
Conditions V_{in} : 100 VAC V_{out} : Nominal output voltage I_{out} : Maximum output current T_a : 25 °CSwitch on phase angle of input AC voltage
 $\phi = 0^\circ$ Switch on phase angle of input AC voltage
 $\phi = 90^\circ$ Conditions V_{in} : 200 VAC V_{out} : Nominal output voltage I_{out} : Maximum output current T_a : 25 °CSwitch on phase angle of input AC voltage
 $\phi = 0^\circ$ Switch on phase angle of input AC voltage
 $\phi = 90^\circ$ 

2-6. 高調波成分 Input current harmonics

Conditions Vin : 100 VAC
 Vout : Nominal output voltage
 Iout : Maximum output current
 Ta : 25 °C

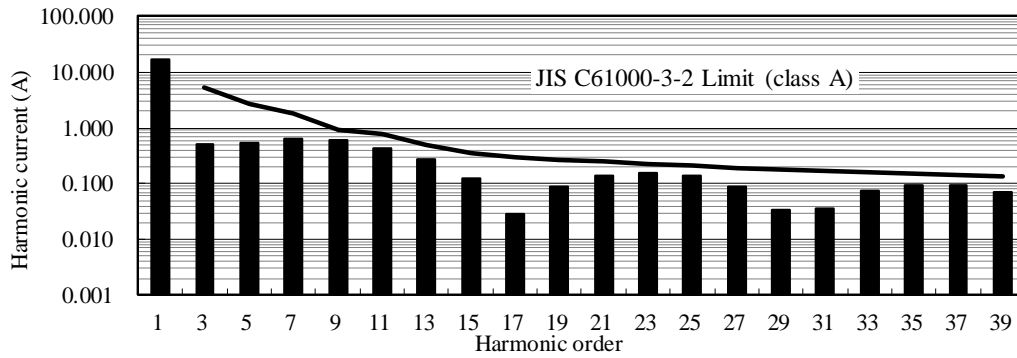

Conditions Vin : 230 VAC
 Vout : Nominal output voltage
 Iout : Maximum output current
 Ta : 25 °C

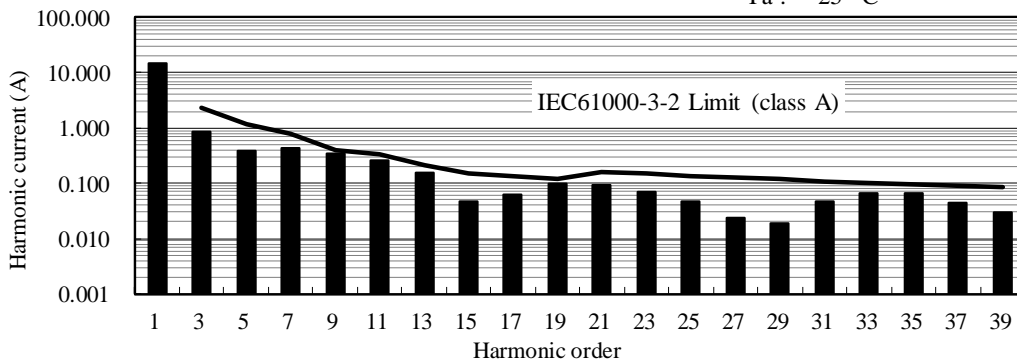

2-7. 入力電流波形 Input current waveform

Conditions Vin : 100 VAC
 Vout : Nominal output voltage
 Iout : Maximum output current
 Ta : 25 °C

Conditions Vin : 200 VAC
 Vout : Nominal output voltage
 Iout : Maximum output current
 Ta : 25 °C

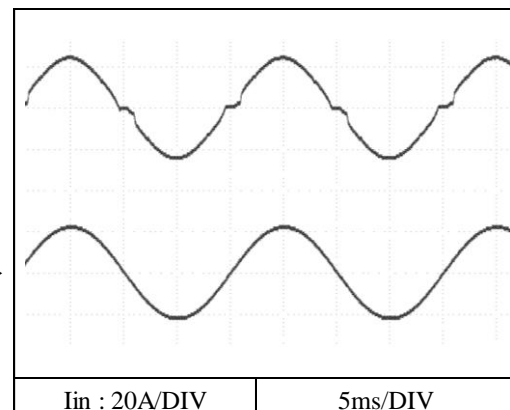
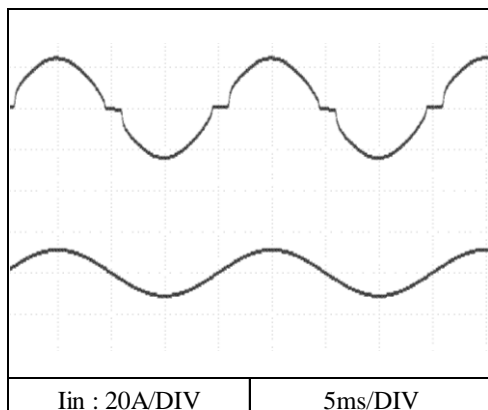

2-8. リーク電流特性 Leakage current characteristics

Conditions Vout : Nominal output voltage
 Iout : 0 A ———
 Maximum - - - -
 Ta : 25 °C
 f : 50 Hz

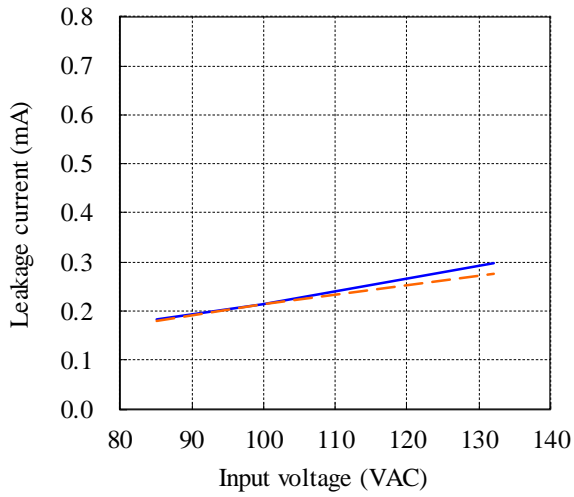

Conditions Vout : Nominal output voltage
 Iout : 0 A ———
 Maximum - - - -
 Ta : 25 °C
 f : 50 Hz

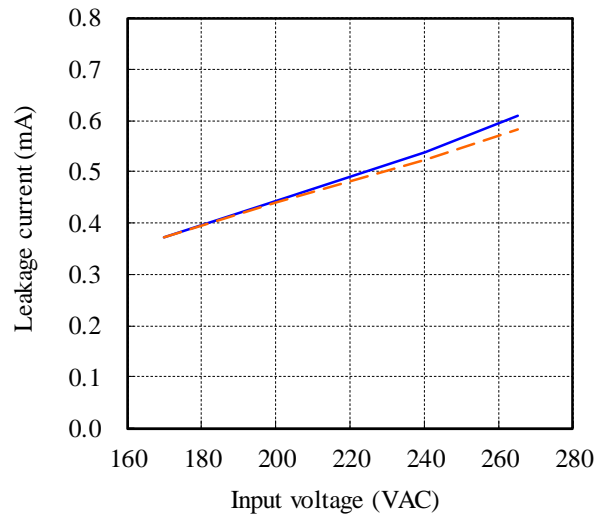

Conditions Vout : Nominal output voltage
 Iout : 0 A ———
 Maximum - - - -
 Ta : 25 °C
 f : 60 Hz

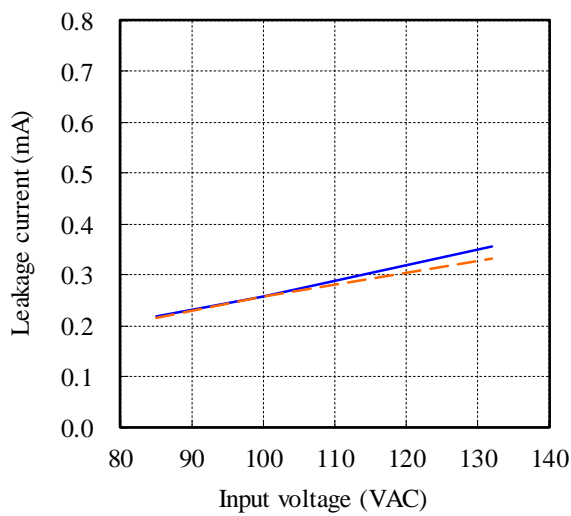

Conditions Vout : Nominal output voltage
 Iout : 0 A ———
 Maximum - - - -
 Ta : 25 °C
 f : 60 Hz

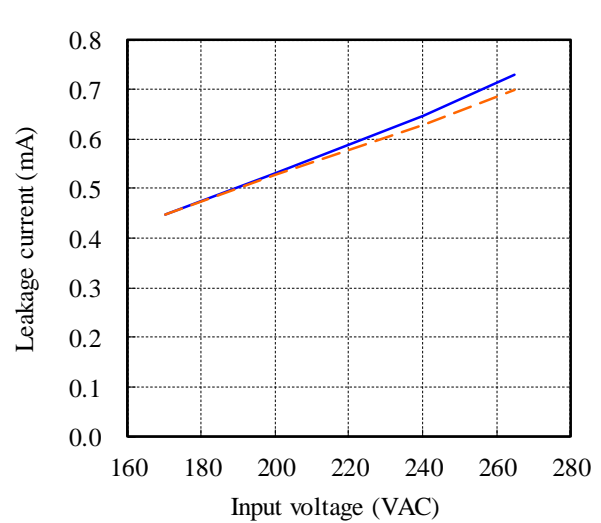

2-9. EMI特性 Electro Magnetic Interference characteristics

雑音端子電圧
Conducted Emission

Conditions Vin : 100 VAC
Iout : 62.5 A
Iaux : 100 %
Ta : 25 °C

Phase : N

Point A (0.24MHz)		
Ref. Data	Limit (dB)	Measure (dB)
QP	79.0	55.2
AV	66.0	55.1

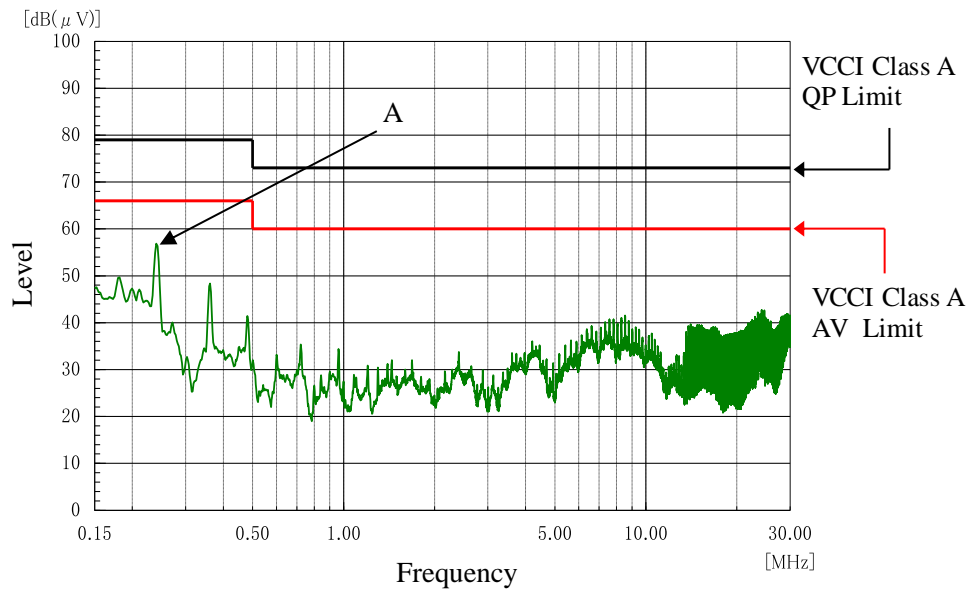

Phase : L

Point B (0.24MHz)		
Ref. Data	Limit (dB)	Measure (dB)
QP	79.0	56.5
AV	66.0	56.4

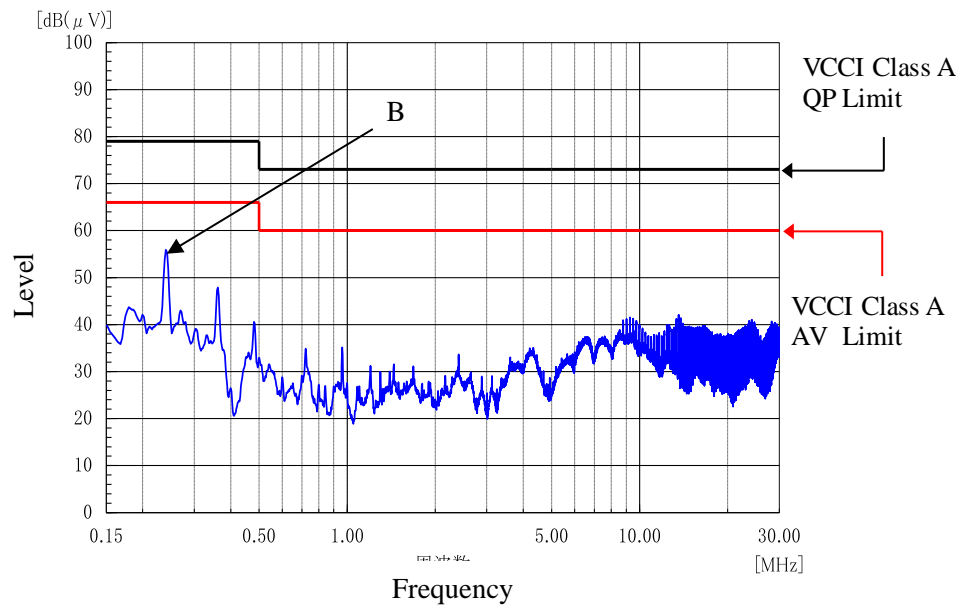

EN55011-A,EN55032-A,FCC-Aの限界値はVCCI class Aの限界値と同じ
Limit of EN55011-A,EN55032-A,FCC-A are same as its VCCI class A.
波形はピーク値
Waveform is peak values.

雑音端子電圧
Conducted Emission

Conditions Vin : 230 VAC
Iout : 125 A
Iaux : 100 %
Ta : 25 °C

Phase : N

Point A (0.24MHz)		
Ref. Data	Limit (dB)	Measure (dB)
QP	79.0	56.4
AV	66.0	56.2

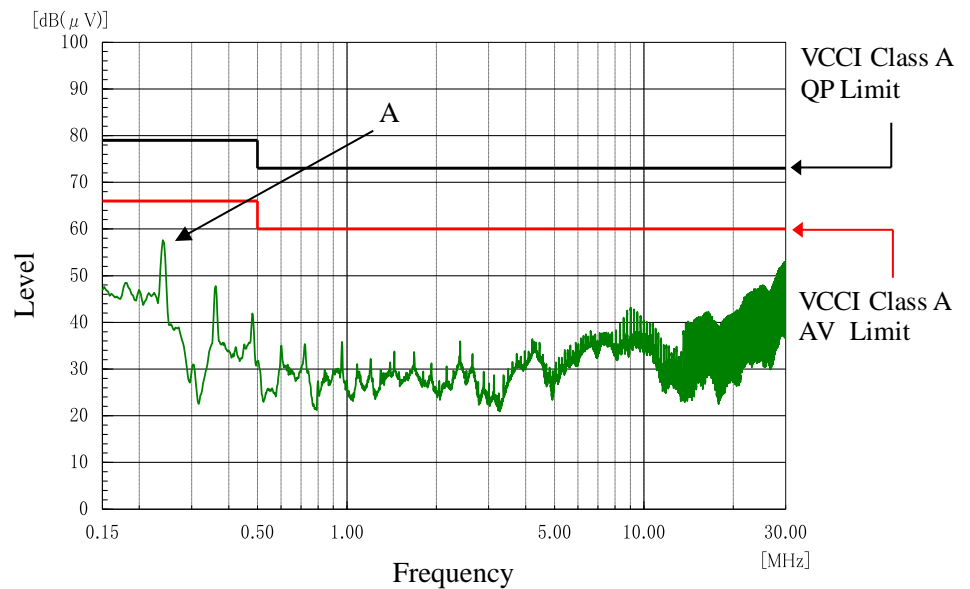

Phase : L

Point B (0.24MHz)		
Ref. Data	Limit (dB)	Measure (dB)
QP	79.0	57.3
AV	66.0	57.2

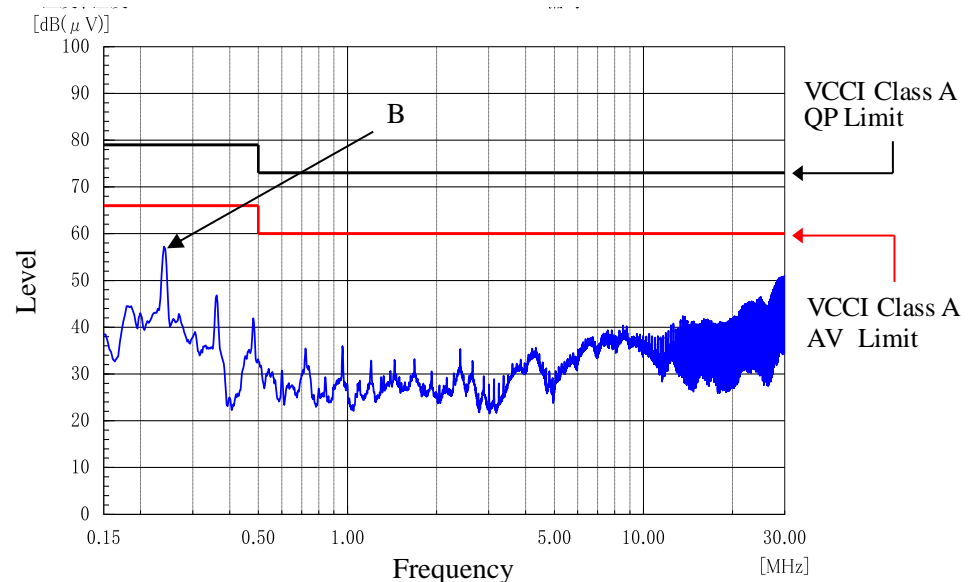

EN55011-A,EN55032-A,FCC-Aの限界値はVCCI class Aの限界値と同じ

Limit of EN55011-A,EN55032-A,FCC-A are same as its VCCI class A.

波形はピーク値

Waveform is peak values.

2-9. EMI特性 Electro Magnetic Interference characteristics

雑音電界強度
Radiated Emission

Conditions Vin : 100 VAC
Iout : 62.5 A
Iaux : 100 %
Ta : 25 °C

HORIZONTAL

Point A (146MHz)		
Ref.	Limit	Measure
Data	(dB)	(dB)
QP	50.0	41.0

Point B (178MHz)		
Ref.	Limit	Measure
Data	(dB)	(dB)
QP	50.0	42.1

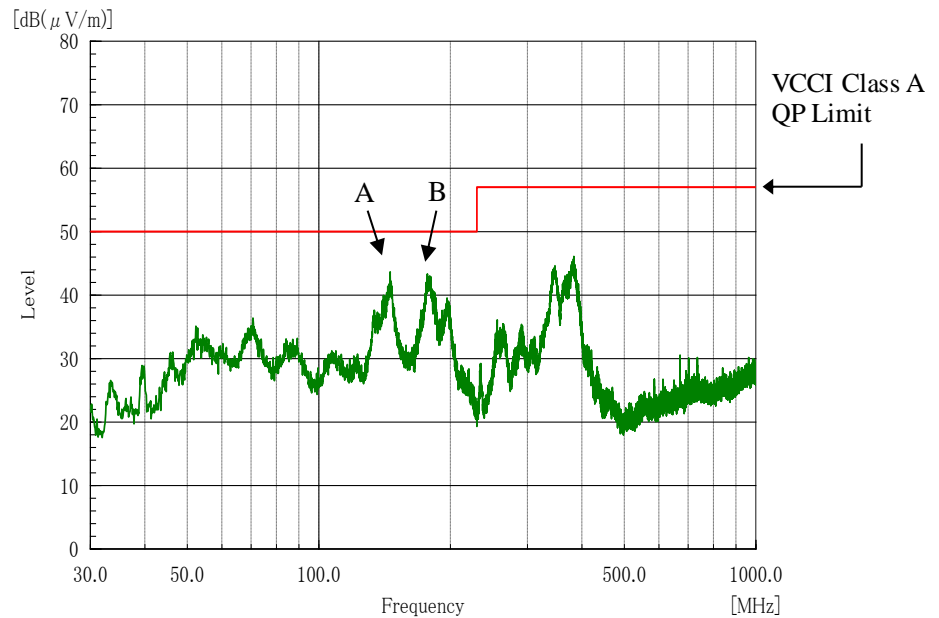

VERTICAL

Point C (33MHz)		
Ref.	Limit	Measure
Data	(dB)	(dB)
QP	50.0	41.5

Point D (39MHz)		
Ref.	Limit	Measure
Data	(dB)	(dB)
QP	50.0	42.2

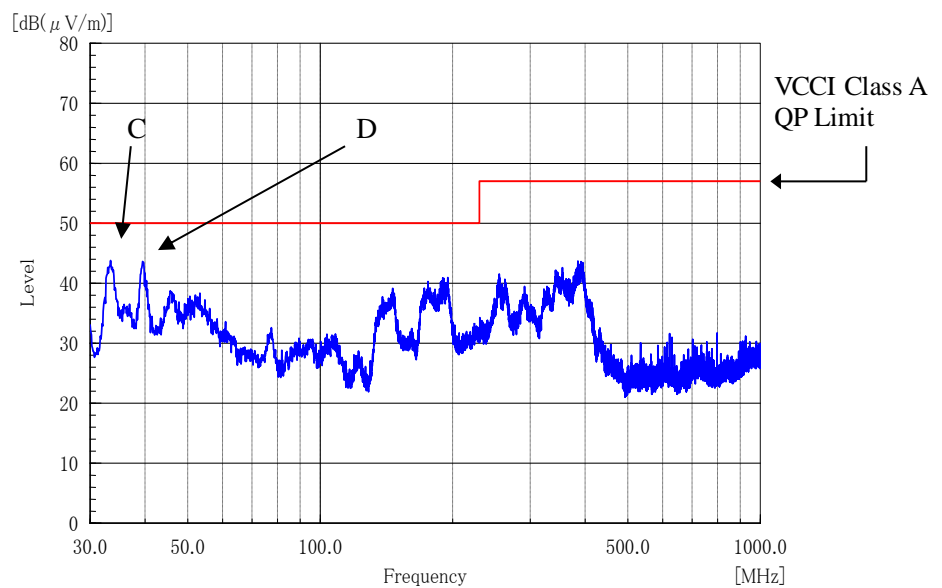

EN55011-A,EN55032-A,FCC-Aの限界値はVCCI class Aの限界値と同じ
Limit of EN55011-A,EN55032-A,FCC-A are same as its VCCI class A.

波形はピーク値

Waveform is peak values.

雑音電界強度
Radiated Emission

Conditions Vin : 230 VAC
Iout : 125 A
Iaux : 100 %
Ta : 25 °C

HORIZONTAL

Point A (144MHz)		
Ref. Data	Limit (dB)	Measure (dB)
QP	50.0	43.3

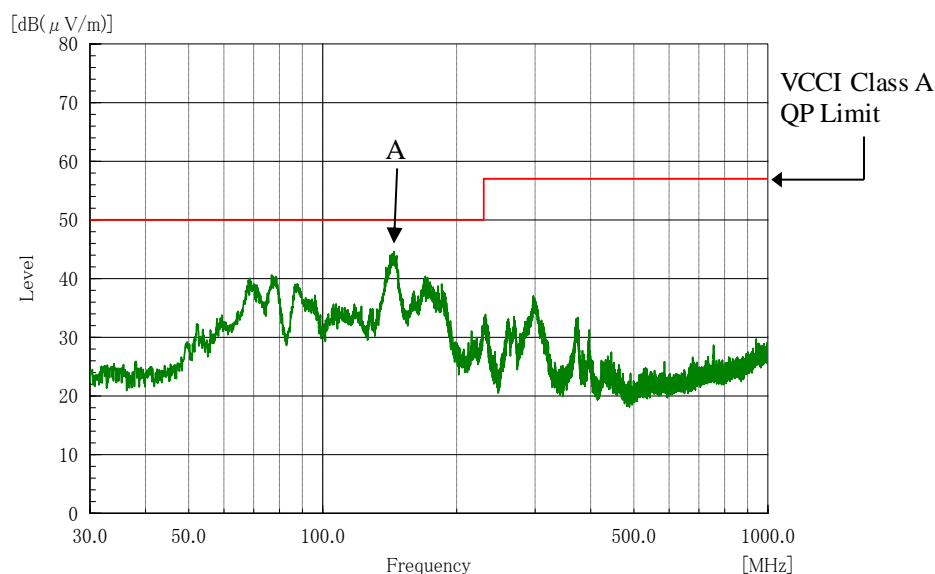

VERTICAL

Point B (35MHz)		
Ref. Data	Limit (dB)	Measure (dB)
QP	50.0	45.1

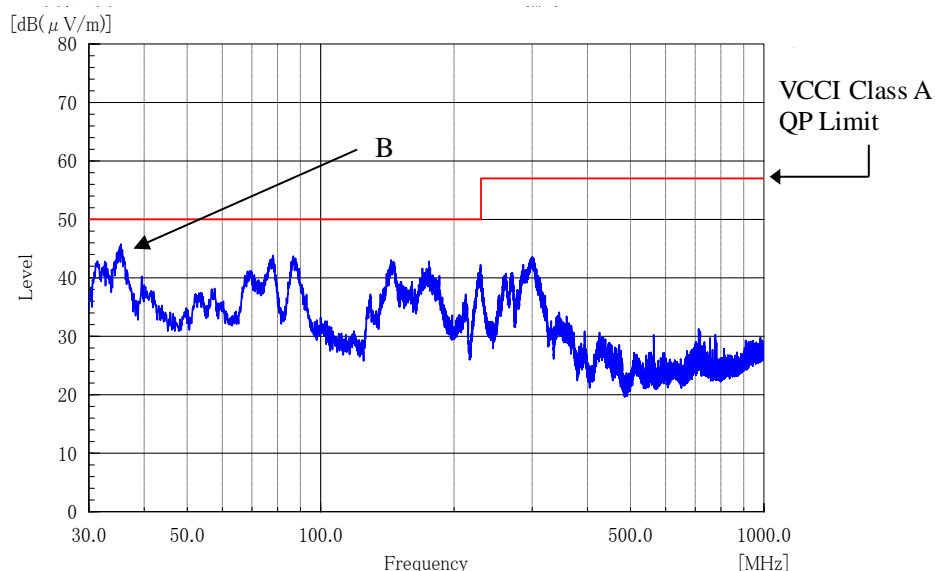

EN55011-A,EN55032-A,FCC-Aの限界値はVCCI class Aの限界値と同じ
Limit of EN55011-A,EN55032-A,FCC-A are same as its VCCI class A.
波形はピーク値
Waveform is peak values.