

CUS100MB

Instruction Manual

BEFORE USING THE POWER SUPPLY UNIT

Be sure to read this instruction manual thoroughly before using this product. Pay attention to all cautions and warnings before using this product. Incorrect usage could lead to an electrical shock, damage to the unit or a fire hazard.

DANGER

Never use this product in locations where flammable gas or ignitable substances are present. There are risks of igniting these substances and exploding by an arcing.

WARNING

- Do not touch this product or its internal components while circuit is live, or shortly after shut down. There may be high voltage or high temperature present and you may receive an electric shock or burn.
- When this product is operating, keep your hands and face away from it as you may be injured by an unexpected situation.
- Do not make unauthorized changes to this product, otherwise you may receive an electric shock and void your warranty.
- Do not drop or insert anything into this product. It might cause a failure, fire and electric shock.
- Do not use this product under unusual condition such as emission of smoke or abnormal smell and sound etc. It might lead to fire and electric shock. In such cases, please contact us. Do not attempt repair by yourself, as it is dangerous for the user.
- Do not operate these products in the presence of condensation. It might lead fire and electric shock.

CAUTION

- This power supply is designed and manufactured for use within an end product such that it is accessible to SERVICE ENGINEERS only.
- Confirm connections to input/output terminals are correct as indicated in the instruction manual before switching on.
- Input voltage, Output current, Output power, ambient temperature and ambient humidity should be kept within specifications, otherwise the product will be damaged.
- Do not operate and store this product in an environment where condensation might occur. In such case, waterproof treatment is necessary.
- Do not use this product in environment with a strong electromagnetic field, corrosive gas or conductive substances.
- For applications, which require very high reliability, it is necessary to provide a fail-safe mechanism in the end equipment.
- Do not inject abnormal voltages into the output of this product. The injection of reverse voltage or over voltage exceeding nominal output voltage into the output terminal might cause damage to internal components.
- Never operate the product under over current or short-circuit conditions, or outside its specified Input Voltage Range. Insulation failure, smoking, burning or other damage may occur.
- This product contains a printed circuit board utilizing surface mounted devices. PCB stress such as bending, twisting etc. could cause damage. Therefore, please handle with care.
- When handling this product, hold the board edge and take care not to touch the component side. When installing this product in apparatus or equipment, mount it on spacers.
- This product has used Power Thermistor to protect the circuit from Inrush Current. Frequent repetition of input on/off might cause damage to internal components because of generating surge current.
- Breaking of internal fuse is considered internal failure. In such cases, please contact us.
- The information in this document is subject to change without prior notice. Please refer to the latest version of the data sheet, etc., for the most up-to date specifications of the product.
- Double pole / neutral fusing.

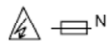

- No part of this document may be copied or reproduced in any form without prior written consent of TDK-Lambda.

Important safety instructions

Servicing

These products are not customer serviceable. Repairs can only be carried out by TDK-Lambda or their authorized agents. These products are not authorized for use as critical components in nuclear control systems, life support systems or equipment for use in hazardous environments without the express written approval of the Managing Director of TDK-Lambda Corporation.

Safety Class of Protection

This power supply is a switch mode power supply for use in applications within a Pollution Degree 2, overvoltage category II environment. Material Group IIIb PCB is used within it.

Input markings and symbols

 Caution refer to supplementary documents

EMC performance

Immunity

Test	Standard	Passed	Comments
Electrostatic discharge	IEC61000-4-2	Level 3	Air discharge 8kV Contact discharge 6kV
Electromagnetic field	IEC61000-4-3	Level 3	10V/m
Fast / burst transient	IEC61000-4-4	Level 3	2.0kV (100kHz)
Surge immunity	IEC61000-4-5	Level 3 Level 4	Normal mode 2.0kV Common mode 4.0kV
Conducted RF immunity	IEC61000-4-6	Level 3	10V
Power frequency magnetic field	IEC61000-4-8	Level 4	30A/m
Voltage dips, variations, interruptions	IEC61000-4-11	Pass	

Emissions

Test	Standard	Comments
EMI	EN55032	Class B (as per CISPR 32)
Conducted harmonics	IEC61000-3-2	Meet Class A at 70% load or less (*1)

*1. Output power is less than 50W for 5V model and 70W for 12V~48V models.

General installation instructions

- 1) CUS100MB is for installation in Class I end equipment only, and therefore must be reliably earthed and professionally installed.
CUS100MB/G2 is optional model for installation in Class II end equipment, and no earthing connection to the power supply is required.
- 2) These products are IPX0, and therefore chemicals/solvents, cleaning agents and other liquids must not be used.
- 3) The first protective earth connection in the final installation must be marked with the protective earth symbol.

Special Instructions for IEC/UL/ 60601-1

- 1) These products are designed for continuous operation within an overall enclosure, and must be mounted such that access to the mains terminals is restricted. See Clause 16, IEC/UL60601-1.
- 2) These products are NOT suitable for use in the presence of flammable anaesthetic mixtures with air or with oxygen or with nitrous oxide.
- 3) These products are classed as ordinary equipment according to IEC/UL60601-1 and are NOT protected against the ingress of water.
- 4) Reference should be made to local regulations concerning the disposal of these products at out of their useful life.
- 5) These products have not been assessed to IEC/UL60601-1-2 (EMC) but EMC test data is available from TDK-Lambda Corporation.
- 6) For Class II installation (CUS100MB/G2), the product needs to be fixed such that they are isolated from unearthed accessible conductive parts by at least 2 MOPP's.
- 7) For IEC/EN 60601-1 2nd Edition, UL 60601-1 1st Edition, CSA-C22.2 No. 601.1-M90, these products have a reinforced insulation barrier between input and output. For IEC/EN 60601-1 3rd Edition, ANSI/AAMI ES 60601-1, CSA 22.2 No 60601-1, these products provide reinforced insulation between input and outputs of 2 MOPPs. 1 MOPP from input to earth and 1 MOPP from output to earth.
- 8) All outputs have basic spacing's to earth rated for mains - 250Vac, and due consideration must be given to this in the end product design.
- 9) These products have SELV outputs.

1. Model name identification method

CUS 100 MB – 5 /□

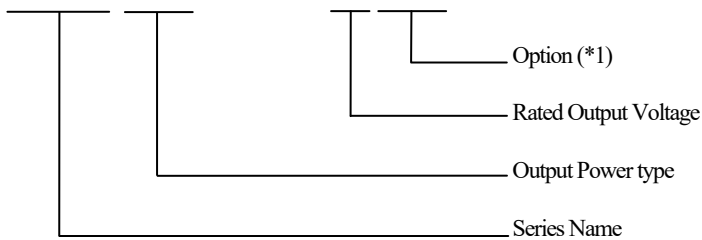

- (*1) Blank : Standard model
 /A : With chassis and cover model
 /B : With base plate model
 /G2 : Class II model

2. Terminal Explanation

- ③ is for standard model except for /A, /B and /G2 model.
 ④⑤⑨ are for standard model and /G2 model, except for /A and /B model.
 For the Protective Earth of /A and /B model, please refer to 7-3-2 and 7-3-3.

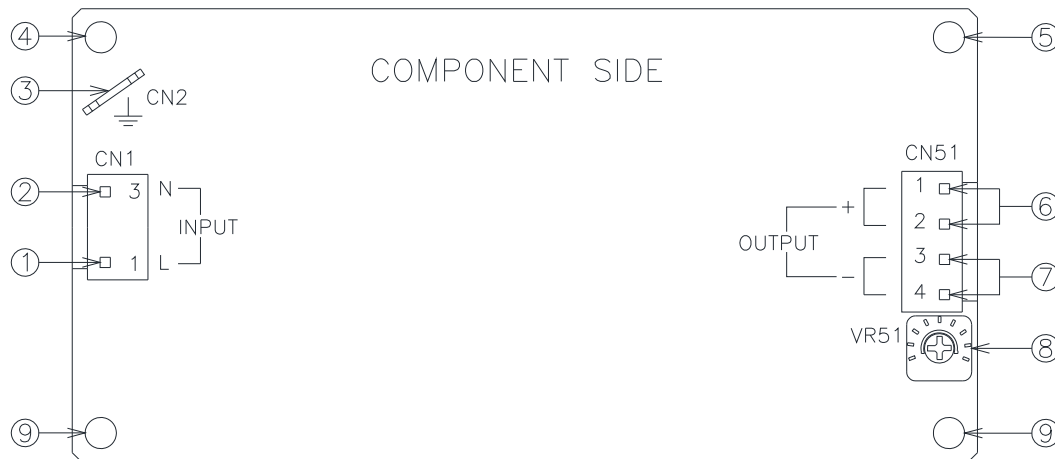

- ① L : AC Input terminal Live line (Fuse in line.)
 ② N : AC Input terminal Neutral line (Fuse in line.)
 ③ \perp : \perp Terminal CN2(Protective Earth)
 ④ Mounting hole (hole diameter : $\phi 3.5\text{mm}$)
 This hole is electrically connected to CN2.
 ⑤ Mounting hole (hole diameter : $\phi 3.5\text{mm}$)
 ④ and ⑤ Must be connected to earthed metal plate/chassis of the equipment by metal spacers in Class I installation.
 ⑥ + : + Output Terminal
 ⑦ - : - Output Terminal
 ⑧ V.ADJ : Output voltage adjust trimmer. The output voltage rises when the trimmer is turned clockwise.
 ⑨ Mounting hole (hole diameter : $\phi 3.5\text{mm}$)
 This hole is used for support the unit.

3. Terminal Connection Method

Pay attention to the input wiring. If it is connected to wrong terminal, the power supply will be damaged.

- Input must be off when making connections.
- \perp terminal must be connected to protective earth of the equipment (Except for /G2 model).
- Output current of each terminal pin must be less than 10A.
- The output load line and input line shall be separated to improve noise sensitivity.
- Do not apply stress to PCB, when connecting or removing connector.
- Use input/output connector (housing) specified by the table below.
- Use recommended crimping tool. Connector is not included with this product. (Refer to the following)

Input/Output Connector

	Model	Connector	Housing	Terminal Pin	Maker
Input (CN1)	Common	B2P3-VH(LF)(SN)	VAR-2 / VHR-3N	SVH-41T-P1.1 BVH-41T-P1.1	J.S.T.
Output (CN51)	Common	B4P-VH(LF)(SN)	VHR-4N		
FG TAB (CN2)	Common	---	22~18AWG: STO-21T-250N 18~14AWG: STO-61T-250N	---	J.S.T.

Hand Crimping Tool : YC-930R, YC-931R (J.S.T.)

4. Block Diagram

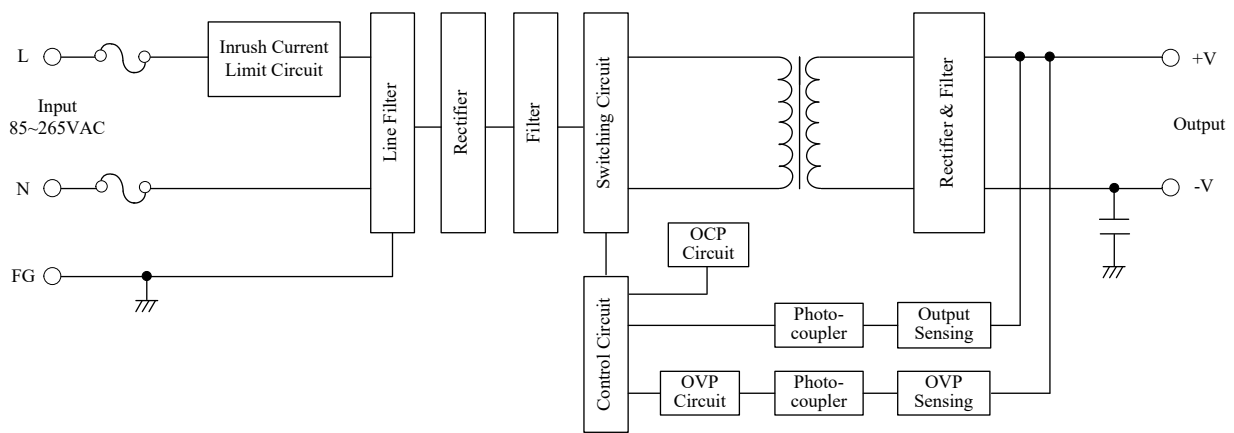

● Fuse rating
3.15A

● Circuit topology, switching frequency
100KHz

5. Sequence Time Chart

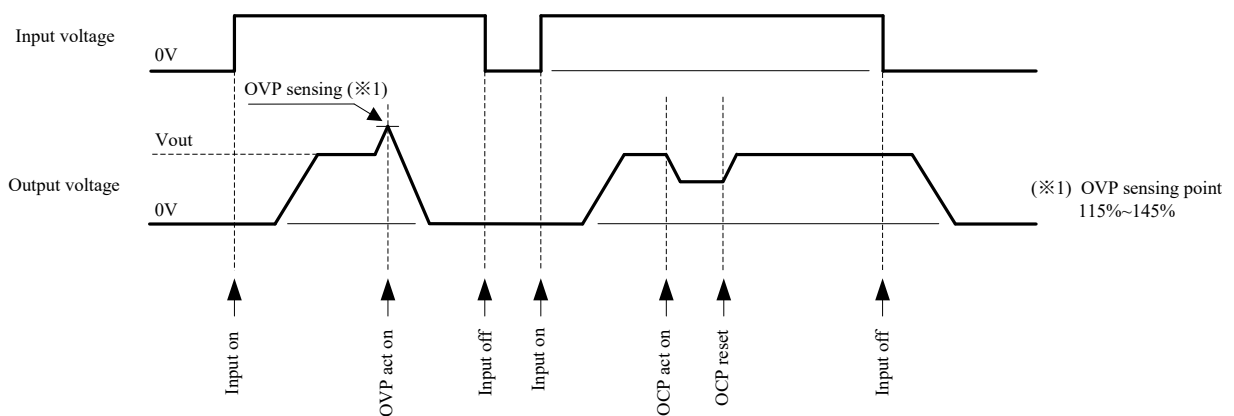

6. Explanation of Function and Precautions

6-1. Input Voltage Range

Input voltage range is single phase 85-265VAC(47-63Hz). Never operate the unit out of the specified input voltage range to avoid unit failure. For cases where conformance to various safeties required, input voltage range will be 100-240VAC (50-60Hz). If input voltage is less than 115VAC, output power need to be derated.

Derating curve of the Input voltage

CUS100MB-5		CUS100MB-12, -15 -18, -24, -28, -36, -48	
Input Voltage (VAC)	Load (%)	Input Voltage (VAC)	Load (%)
85	80	85	80
100~265	100	115~265	100

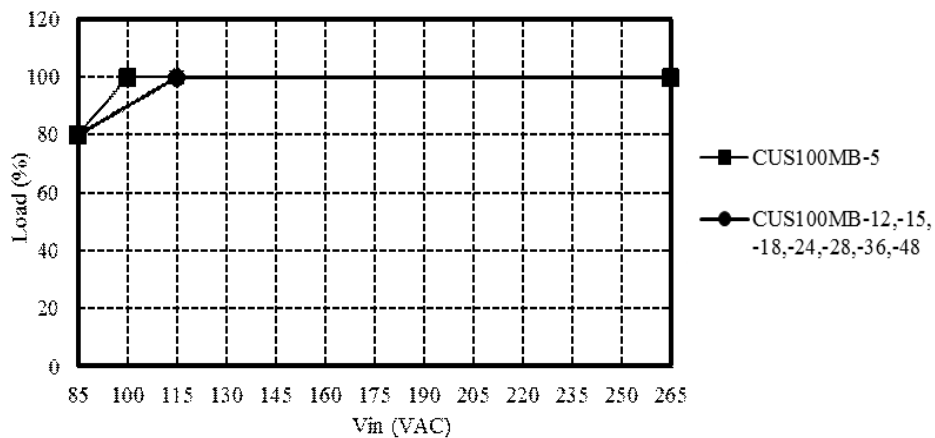

6-2. Output Voltage Range

Output voltage is set the rated value at shipment. V.ADJ trimmer (VR51) can adjust the output voltage within the range. Output voltage range refers to the specification. To turn the trimmer clockwise, the output voltage will be increased. Take note when the output voltage is increased excessively, over voltage protection (OVP) function may be triggered and voltage will be shut down. Furthermore, when increasing the output voltage reduce the output current so as not to exceed the maximum output power.

6-3. Inrush Current

These products equipped Power thermistor to limit the inrush Current. Higher inrush current will flow at higher ambient temperature or re-input condition. Please select input switch and fuse carefully with the high temperature and re-input the power condition. The Inrush Current value is under cold start at 25°C in the specification.

6-4. Over Voltage Protection (OVP)

The OVP function (Inverter shut down method, manual reset type) is provided. Please refer to its specification for OVP operating range. When OVP triggers, the output will be shut down. To reset OVP, remove the input of power supply for a few minutes, and then re-input. In addition, the setting value of OVP is fixed and not adjustable. Pay attention not to apply higher voltage externally to the output terminal to avoid unit failure. In case of inductive load, put protective diode in series to the output power line.

6-5. Over Current Protection (OCP)

The OCP is hiccup mode with automatic recovery. The outputs will be automatically recovered when the overload condition is canceled.

OCP function operates when the output current exceeds 105% of maximum DC output current of specification. Never operate the unit under over current or shorted conditions for more than 30seconds, which may leads damage or insulation failure. OCP setting is fixed and not to be adjusted externally.

6-6. Output Ripple & Noise

The standard specification for maximum ripple value is measured according to measurement circuit specified as below. When load lines are longer, ripple will becomes larger. In this case, electrolytic capacitor, film capacitor, etc. might be necessary to use across the load terminal. The output ripple cannot be measured accurately if the probe ground lead of oscilloscope is too long.

A circuit reducing light load input power consumption is built in this model. When output current is within 0-35% of rated load, the internal switch element is intermittent operated, and the switching loss is decreased. The specification of the Ripple & Noise changes by this intermittent operation. The dynamic load response characteristic changes by this intermittent operation too. Different input voltage and dynamic load condition has different dynamic load response characteristic. Please contact us for details.

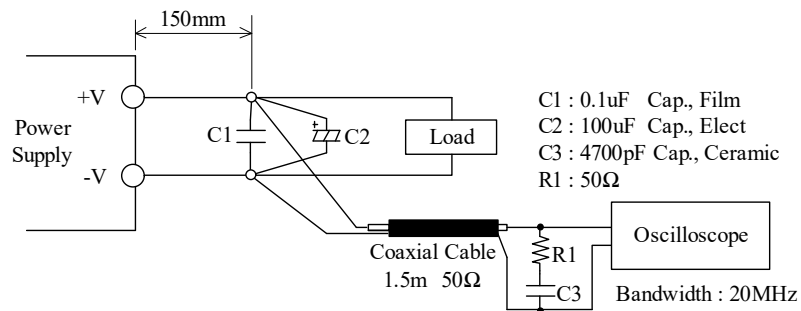

6-7. Series Operation

For series operation, either method (A) or (B) is possible.

Method (A)

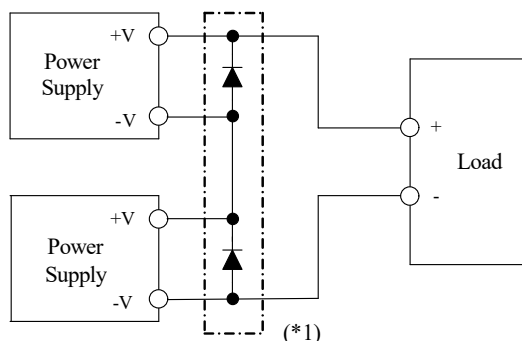

Method (B)

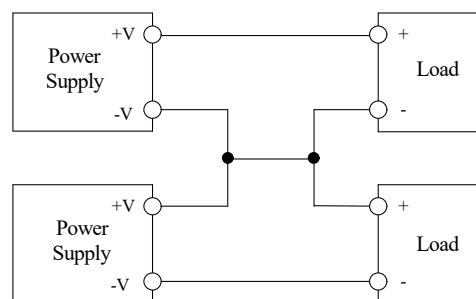

(*1)Please select a bypass diode with maximum forward current rating more than output load current. And maximum reverse voltage must withstand each power supply output voltage.

6-8. Parallel Operation

For parallel operation, method (B) is possible.

(A) To increase the Output Current is not possible.

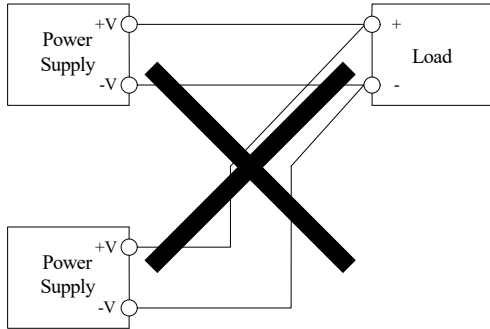

(B) To use as Backup Power Supply.

1. Adjust the output voltage of each power supply to be the same.
 2. Set power supply output voltage higher by the forward voltage drop (V_f) of diode.
- Use within the specification for output voltage and output power.

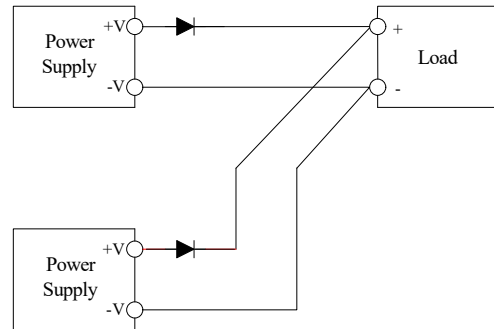

6-9. Isolation Test

Isolation resistance between Output and \perp (Protective Earth) is more than 100M Ω at 500VDC. For safety operation, voltage setting of DC isolation tester must be done before the test. Ensure that the unit is fully discharged after the test.

Output - \perp (Protective Earth) : 500VDC More than 100M Ω

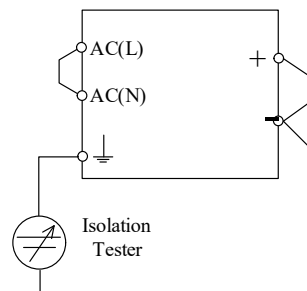

6-10. Withstand Voltage

These products are designed to withstand 4.0kVAC between input and output, 2.0kVAC between input and \perp , and 1.5kVAC between output and \perp each for 1 minute. When testing withstand voltage, set current limit of the withstand voltage test equipment to 20mA. The applied voltage must be gradually increased from zero to the testing value and then gradually decreased for shut down. When timer is used, the power supply may be damaged by high impulse voltage at timer switch on and off. Connect input and output as follows.

Input - Output(Dashed line) : 4.0kVAC 1min(20mA)

Input - \perp (Protective Earth)(Solid line) : 2.0kVAC 1min(20mA)

Output - \perp (Protective Earth) : 1.5kVAC 1min(20mA)

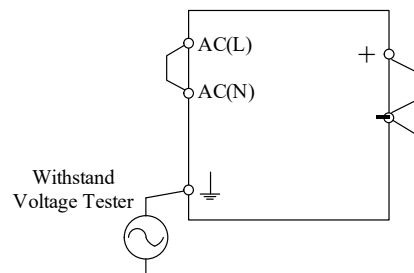
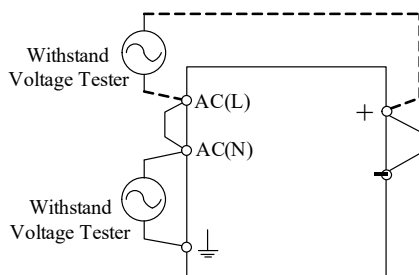

Instructions for using the power supply in customer's system

1. If the output of power supply is connected to FG in the application, the withstand voltage test between input and output (FG) should be tested at 2kVAC.
2. If there is external noise filter and Y-caps connected at the input and output of the power supply, the voltage distribution between primary and secondary circuit will be changed during the withstand voltage test, and may cause test fail. In this case, please contact TDK-Lambda for the technical support and instructions.

7. Mounting

7-1. Mounting Directions

7-1-1. Mounting directions for models (except CUS100MB/A)

Recommended standard mounting direction is (A). Mounting direction (B)-(E) are also possible.

(A) Standard mounting

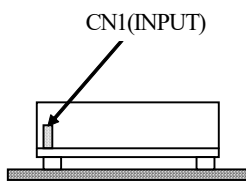

(B)

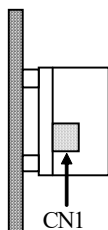

(C)

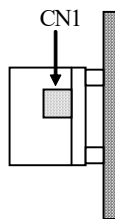

(D)

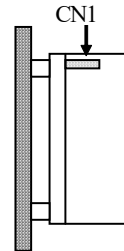

(E)

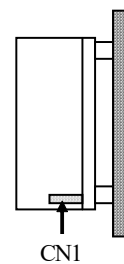

7-1-2. Mounting directions for CUS100MB/A

Recommended standard mounting direction is (A). Mounting direction (B)-(E) are also possible.

Please use the mounting holes on bottom side of the power supply, do not use the side of the chassis for power supply mounting.

(A) Standard mounting

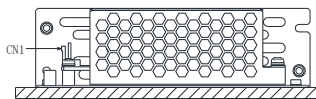

(B)

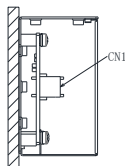

(C)

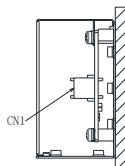

(D)

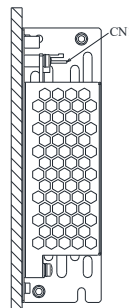

(E)

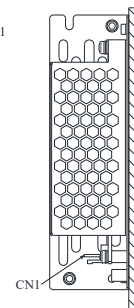

7-2. Output Derating

7-2-1. Output derating for CUS100MB and CUS100MB/B

Make sure that the specified temperature range is maintained.

(1) 5V model

Convection Cooling: Mounting A,B,C,D
 & Force Air Cooling: Mounting A,B,C,D,E

Ta (°C)	Load (%)
-20 - +40	100
50	90
60	75
70	50

Convection Cooling: Mounting E

Ta (°C)	Load (%)
-20 - +35	100
45	90
55	75
65	50

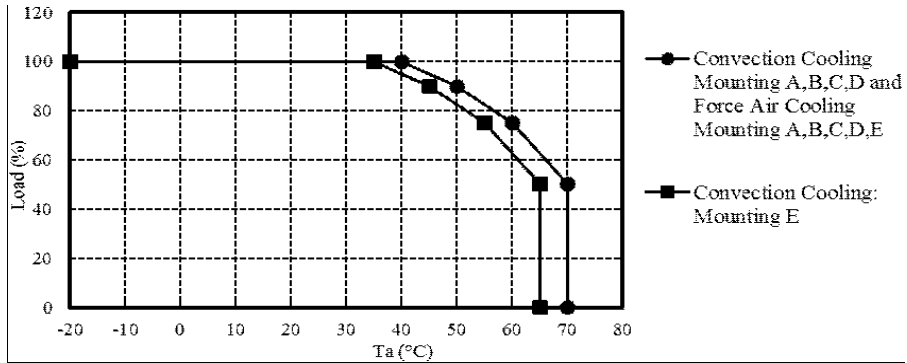

(2) 12V, 15V, 18V model

Convection and Force Air Cooling

Mounting: A,B,C,D,E

Ta (°C)	Load (%)
-20 - +50	100
70	50

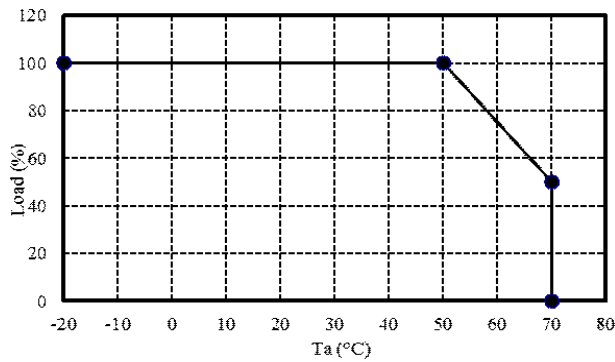

(3) 24V Model

Convection Cooling
 Mounting: A,B,C,D,E

Ta (°C)	Load (%)
-20 - +40	100
70	40

Force Air Cooling
 Mounting: A,B,C,D,E

Ta (°C)	Load (%)
-20 - +50	100
70	50

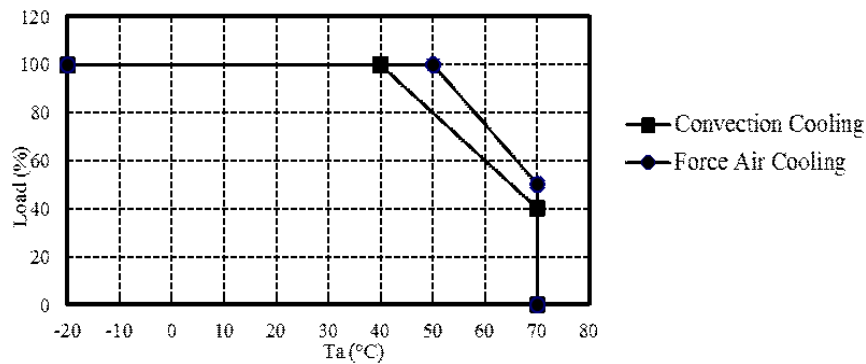

(4) 28V model

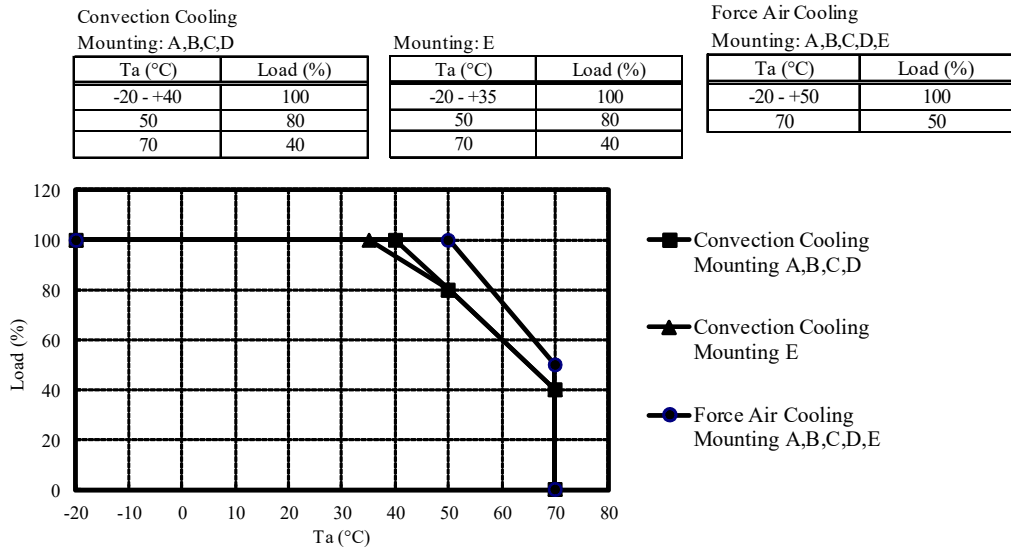

(5) 36V model

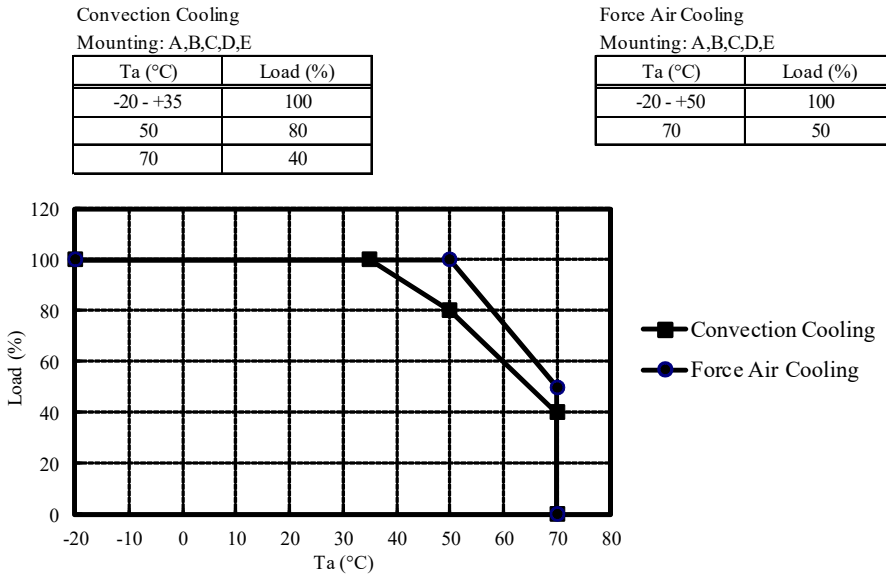

(6) 48V Model

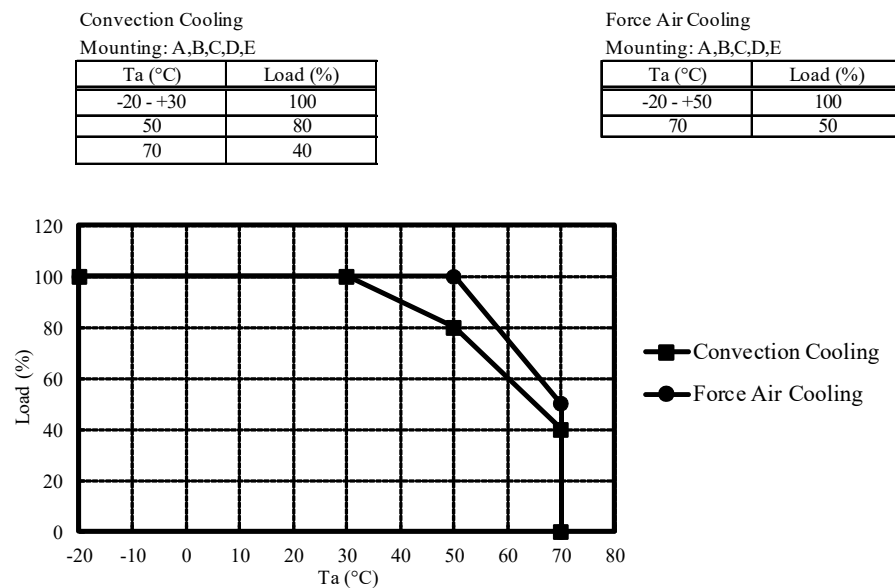

▪ **Condition of force air cooling**

Recommend force air cooling with air velocity more than 1.2m/s (measured at component side of PCB) and air must flow through component side, so that the maximum temperature of the surface of the following components will not exceed max temperature in the table.

Components	C5	T1
Max temperature	95°C	115°C

Absolute temperature = Temperature rise + Ambient temperature

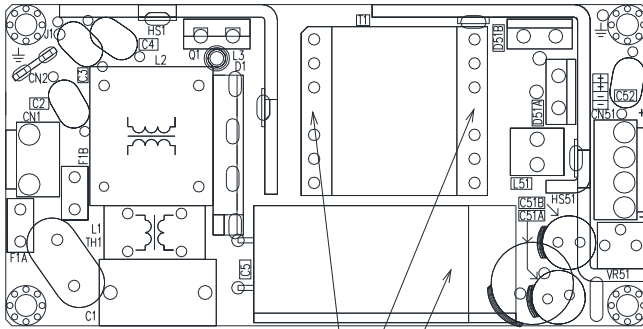

TEMPERATURE RISE TEST POINTS

7-2-2. Output derating for CUS100MB/A.

CUS100MB/A is convection cooling type. Make sure that the specified temperature range is maintained.

CUS100MB-5/A
 Mounting A,B,C,D,E

Ta (°C)	Load (%)
-20 - +30	100
40	90
70	40

CUS100MB-12/A,15/A,18/A,24/A,28/A,36/A,48/A
 Mounting A,B,C,D,E

Ta (°C)	Load (%)
-20 - +40	100
70	40

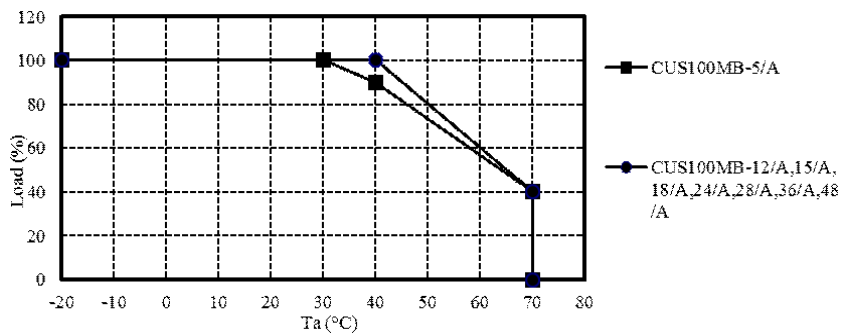

7-3. Mounting Method

7-3-1. Mounting method for standard model

Note: Except /A, /B and /G2 model.

All four mounting holes on this model should be utilized for best electrical and mechanical performance, with 8mm (minimum height) metal standoffs.

▪ **Mounting Holes size**

4 holes ϕ 3.5mm.

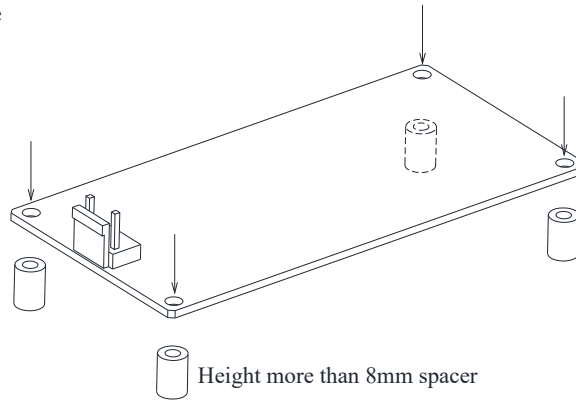

Refer to the shadow in the figure below for allowable area touched by conductive material on top and bottom side of the PCB.



▪ **Condition to meet EMI, EMC, Isolation, Withstand Voltage and Cooling requirement.**

Keep 4mm space minimum from the surface and sides of power supply, 8mm space minimum from the bottom side of PCB to meet safety requirement, or more space depend on safety requirement. If the space is not enough, the specification of isolation and withstand voltage will not be satisfied.

More space may be required in the surrounding of power supply and the upper area of components for effective cooling depends on the application conditions.

⊥ terminal (Protective Earth) must be connected to the earth terminal of the equipment, also the two mounting holes (as shown below) needed to be connected to earthed metal plane or metal chassis of end product by metal spacer to ensure EMC and EMI performance.

All equipment ideally should be mounted inside an earthed shielded metal box. Alternatively an earthed metal plate can be used to mount the power supply and load.

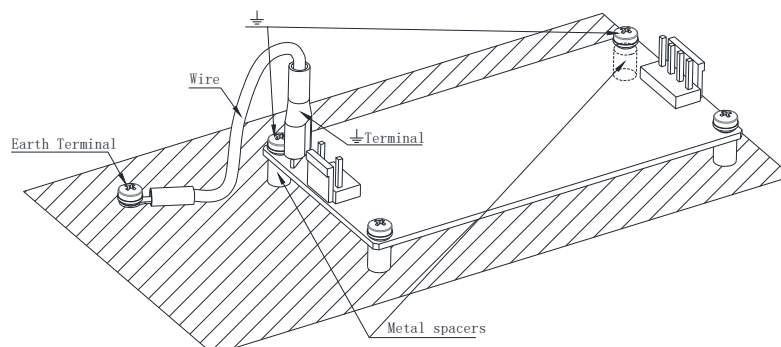

7-3-2. Mounting method for /B model

/B model is optional model with metal plate on the bottom.

The mounting holes on the metal plate are for power supply fixing. The M3 stud near the input connector is used to connect to the protective earth.

Refer to the /B model outline drawings for the detailed dimensions.

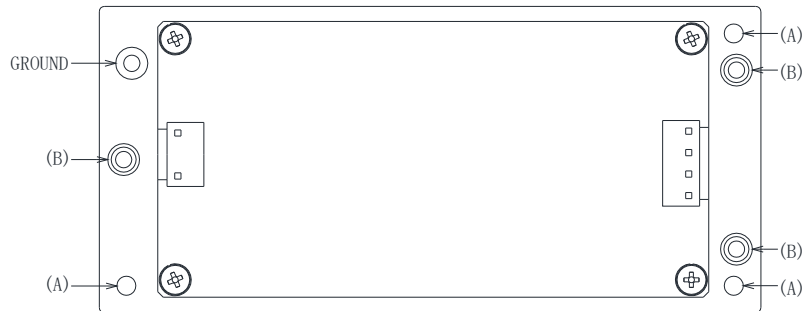

■ Mounting Holes

A: 3- ϕ 3.5 holes for mounting screws to fix the power supply from top.

B: 3-M3 tapped, embossed and countersink holes for mounting screws to fix the power supply from bottom.

Ground: M3 stud for protective earth

■ Condition to meet EMI, EMC, Isolation, Withstand Voltage and Cooling.

Keep more than 4mm space from the top of components and the sides of PCB to meet safety requirement. If the space is not enough, the specification of isolation and withstand voltage will not be satisfied.

More space may be required in the surrounding of power supply and the upper area of components for effective cooling depends on the application conditions.

All equipment ideally should be mounted inside an earthed shielded metal box. Alternatively an earthed metal plate can be used to mount the power supply and load to ensure the EMI and EMC performance.

7-3-3. Mounting method for /A model

/A model is optional model with metal chassis and cover.

The mounting holes on the bottom of the chassis are for power supply fixing. The M3 stud near the input connector can be used to connect to the protective earth.

Refer to the /A model outline drawings for the detailed dimensions.

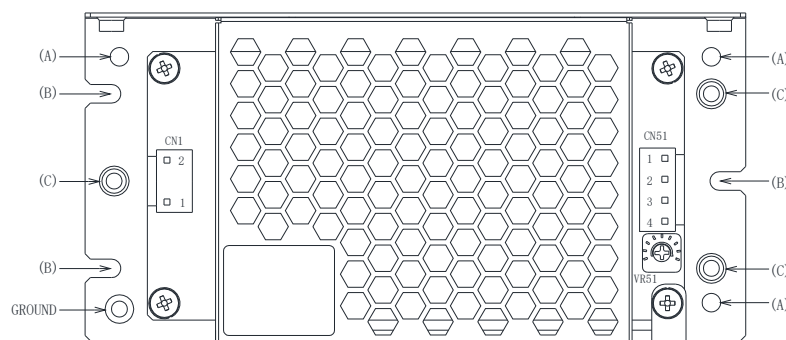

■ Mounting Holes

A: 3- ϕ 3.5 holes for mounting screws to fix the power supply from top.

B: 3- ϕ 3.5 holes for mounting screws to fix the power supply from top.

C: 3-M3 tapped, embossed and countersink holes for mounting screws to fix the power supply from bottom.

Ground: M3 stud for protective earth

▪ **Condition to meet EMI, EMC, Isolation, Withstand Voltage and Cooling.**

- (1) This series is convection cooling type. In consideration of the heat radiation and safety, please keep a distance of more than 15mm between the power supply and the peripheral parts. When lining up multiple units, please make sure to place them 15mm or more apart from each other.
- (2) Recommended torque for mounting screws of M3 screw : 0.49 N·m (5.0 kgf·cm).
- (3) All equipment ideally should be mounted inside an earthed shielded metal box. Alternatively an earthed metal plate can be used to mount the power supply and load to ensure the EMI and EMC performance.

7-3-4. Mounting method for /G2 model

/G2 model is optional model for installation in class II end equipment (without ground connection), such as used inside of a plastic enclosure.

All four mounting holes on this model should be utilized for support the power supply

Keep enough space from the surrounding of the power supply for safety and cooling requirement, these products need to be fixed such that they are isolated from unearthed accessible conductive parts by at least 2 MOPP's for Class II installation.

8. EMC and Wiring Method

This power supply is primarily designed and manufactured to be used and enclosed in other equipment. The installation, wiring, grounding and end application of the switching power supply in the equipment system may influence its EMC characteristics. Therefore, the EMC performance has to be tested on end system level. Additional filtering may be required depends on application and installation methods.

Please refer to following application notes which may help to improve EMC performance.

- (1) The output load line and input line shall be separated each other and twisted individually to improve noise.
- (2) Use all lines as thick and short as possible to made lower impedance.
- (3) Noise can be reduced by attaching a capacitor to the load terminals.
- (4) For safety and EMI considerations, connect \perp (Protective Earth) terminal and Frame Ground terminal of equipment firmly.
- (5) Use Clamp or toroidal ferrite core on Input and Output wires for 2or 3 turns for CUS100MB/G2 5V~36V models to meet EN55011/EN55032-B,FCC-Class B EMI. Use any appropriate commercially available ferrite core from local vendor.

9. External Fuse Rating

Refer to the following fuse rating when selecting the external fuses that are to be used on input line. Surge current flows when line turns on. Have to use slow-blow or time-lag type fuse, not fast-blow fuse. Fuse rating is considered by in-rush current value at line turn-on. Do not select the fuse according to input current (RMS.) values under the actual load condition

CUS100MB: 3.15A

10. Before concluding that the unit is at fault

- (1) Check if the rated input voltage is connected.
- (2) Check if the wiring of input and output is correct.
- (3) Check if the wire thickness is enough.
- (4) Check if the output current and output power does not over specification.
- (5) Check if the output voltage adjust trimmer (V.ADJ) is properly adjusted. OVP might be triggered and output is shut down.
- (6) Audible noise can be heard when input voltage waveform is not sinusoidal wave.
- (7) Audible noise can be heard during Dynamic-Load operation.
- (8) Ensure that a large capacitor is not connected across the output terminals. Please use within maximum capacitance shown below.

MODEL	Maximum external capacitance							
	5V	12V	15V	18V	24V	28V	36V	48V
CUS100MB	10000uF	10000uF	5600uF	5600uF	4500uF	4000uF	4000uF	2000uF

11. Altitude

CUS100MB is safety approved for operation at below altitude.

- Up to 5000m by IEC62368-1 clearance requirement.
- Up to 5000m by IEC60601-1 clearance requirement.

Thermal evaluation should be considered for products operating at elevated altitudes above 2000m.

12. The Life Expectancy

The life of the power supply depends on the life of the built-in aluminum electrolytic capacitor. The life is described in reliability data.

The life of the aluminum electrolytic capacitor varies depending on the method of mounting the power supply, the load current, and the ambient temperature. Please refer to “Electrolytic Capacitor Lifetime”.

Please do not use the product which passed over the life expectancy. There is a risk of unexpected output shutdown and specifications may not be satisfied.

Please contact us for maintenance or exchange the product which passed over the life expectancy.

13. Warranty Period

This product is warranted for a period of 3 years from the date of shipment.

For damages occurring at normal operation within this warranty period, repair is free of charge.

Please read the General Safety Instruction before using the products.

3 years warranty applies but not limited to the following.

- (1) Average operating temperature (ambient temperature of the power supply unit) is under 40°C.
- (2) 3 years warranty base on 24 hours/day operation at 100% load.

Please refer to electrolytic capacitor life time from reliability data for various application conditions such as mounting, load derating, operating ambient temperature etc.

Customer system design could be improved with better electrolytic capacitor life time by selecting proper application method.

Following cases are not covered by warranty.

- (1) Improper usage like dropping products, applying shock and defects from operation exceeding specification of the units.
- (2) Defects resulting from natural disaster (fire, flood etc.).
- (3) Unauthorized modifications or repair.

14. CE Marking / UKCA Marking

CE MARKING

CE Marking, when applied to a product or packing material for a product covered by this handbook, indicates compliance with the Low Voltage Directive, EMC Directive and RoHS Directive.

UKCA MARKING

UKCA Marking, when applied to a product or packing material for a product covered by this handbook, indicates compliance with the Electrical Equipment (Safety) Regulations, Electromagnetic Compatibility Regulations and Restriction of the Use of Certain Hazardous Substances in Electrical & Electronic Equipment Regulations.