

CUS350M Series

Instruction Manual

BEFORE USING THE POWER SUPPLY UNIT

Be sure to read this instruction manual thoroughly before using this product. Pay attention to all cautions and warnings before using this product. Incorrect usage could lead to an electrical shock, damage to the unit or a fire hazard.

DANGER

1. Never use this product in locations where flammable gas or ignitable substances are present.

INSTALLATION WARNING

1. When installing, ensure that work is done in accordance with the instruction manual. When installation is improper, there is risk of electric shock and fire.
2. Installation shall be done by Service personnel with necessary and appropriate technical training and experience. There is a risk of electric shock and fire.
3. Do not cover the product with cloth or paper etc. Do not place anything flammable around. This might cause damage, electric shock or fire.

WARNING ON USE

1. Do not touch this product or its internal components while circuit in operation, or shortly after shutdown. You may receive a burn.
2. While this product is operating, keep your hands and face away from it as you may be injured by an unexpected situation.
3. For products with no cover, do not touch them as there are high-voltage and high temperature parts inside. Touching them might cause injury such as electric shock or burn.
4. There are cases where high voltage charge remains inside the product. Therefore, do not touch even if they are not in operation as you might get injured due to high voltage and high temperature. You might also get electric shock or burn.
5. Do not make unauthorized changes to this product nor remove the cover as you might get an electric shock or might damage the product. We will not be held responsible after the product has been modified, changed or dis-assembled.
6. Do not use this product under unusual condition such as emission of smoke or abnormal smell and sound etc. Please stop using it immediately and shut off the product.
It might lead to fire and electric shock. In such cases, please contact us. Do not attempt repair by yourself, as it is dangerous for the user.
7. Do not operate and store these products in environments where condensation occurs due to moisture and humidity.
It might lead fire and electric shock.
8. Do not drop or apply shock to this product. It might cause failure. Do not operate these products mechanical stress is applied.

CAUTION ON MOUNTING

1. Confirm connections to input/output terminals are correct as indicated in the instruction manual before switching on.
2. Input voltage, Output current, Output power, ambient temperature and ambient humidity should be kept within specifications, otherwise the product will be damaged.
3. Input line, please use the wires as short and thick as possible.
4. Do not use this product in special environment with strong electromagnetic field, corrosive gas or conductive substances and direct sunlight, or places where product is exposed to water or rain.
5. Mount this product properly in accordance with the instruction manual, mounting direction and shall be properly be ventilated.
6. Please shut down the input when connecting input and output of the product.
7. When installing in environment where conductive foreign, dust and liquid may be present, please consider penetration of above foreign material in the power supply by installing filter, to prevent trouble or malfunction.

CAUTION ON USE

1. Product individual notes are shown in the instruction manual. If there is any difference with common notes individual notes shall have priority.
2. Before using this product, be sure to read the catalog and instruction manual. There is risk of electric shock or damage to the product or fire due to improper use.
3. Input voltage, Output current, Output power, ambient temperature and ambient humidity should be kept within Specifications, otherwise the product will be damaged, or cause electric shock or fire.
4. If the built-in fuse is blown, do not use the product even after replacing the fuse, as there is risk of abnormality inside. Be sure to request repair to our company.
5. For products without built-in protection circuit (element, fuse, etc.), insert fuse at the input to prevent smoke, fire during abnormal operation.
As for products with built-in protection circuit, depending on usage conditions, built-in protection circuit might not work. It is recommended to provide separate proper protection circuit.
6. For externally mounted fuse do not use other fuses aside from our specified and recommended fuse.
7. This product was made for general purpose electronic equipment use and is not designed for applications requiring high safety (such as extremely high reliability and safety requirements. Even though high reliability and safety are not required, this product should not be used directly for applications that have serious risk for life and physical safety. Take sufficient consideration in fail-safe design (such as providing protective circuit or protective device inside the system, providing redundant circuit to ensure no instability when single device failure occurs).
8. When used in environments with strong electromagnetic field, there is possibility of product damage due to malfunction.
9. When used in environment with corrosive gas (hydrogen sulfide, sulfur dioxide, etc.) , there is possibility that they might penetrate the product and lead to failure.
10. When used in environments where there is conductive foreign matter or dust, there is possibility of product failure or malfunction.
11. Provide countermeasure for prevention of lightning surge voltage as there is risk of damage due to abnormal voltage.
12. Connect together the frame ground terminal of the product and the ground terminal of the equipment for safety and noise reduction. If these ground is not connected together, there is risk of electric shock.
13. Parts with lifetime specifications (built-in fan electrolytic capacitor) are required to be replaced periodically. Set the overhaul period depending on the environment of usage and perform maintenance.
Also, note that there are cases when EOL products cannot be overhauled.
14. Take care not to apply external abnormal voltage to the output. Especially, applying reverse voltage or overvoltage more than the rated voltage to the output might cause failure, electric shock or fire.

NOTE

1. Take note that traces of sheet metal processing be left in our power supplies.
2. When disposing product, follow disposal laws of each municipality.
3. Published EMI (CE, RE) or immunity is the result when measured in our standard measurement conditions and might not satisfy specification when mounted and wired inside end-user equipment.
Use the product after sufficiently evaluating at actual end-user equipment.
4. When exporting our products, apply for necessary permissions as required by rules and regulations of Foreign Exchange and Foreign Trade Control Act.
5. Catalogue, contents of the instruction manual may be changed without a prior notice. Refer to latest catalogue or instruction manual.
6. Reproduction or reprinting the instruction manual or its portion is forbidden without our permission.

STORAGE METHOD AND STORAGE PERIOD

1. Store in original package
2. Prevent excessive vibration, impact and external force from being applied during storage.
3. Store in an area out of direct sunlight
4. Temperature and humidity should be within range of product specification (with no condensation)
5. Storage period should be up to two years from receiving.

1. Model name identification method

CUS 350 M-12 □

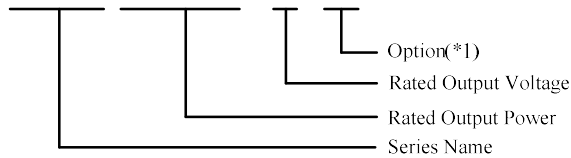

(*1)
 Blank : Standard Model
 /F: Full Function
 /FN: with Fan Supply Model
 /PG: with Power Good Model
 /Others: Denotes for market purpose,
 no construction difference and
 no safety impact,
 such as /0-/9, /a-/z etc.

2. Terminal Explanation

2-1. Terminal Explanation

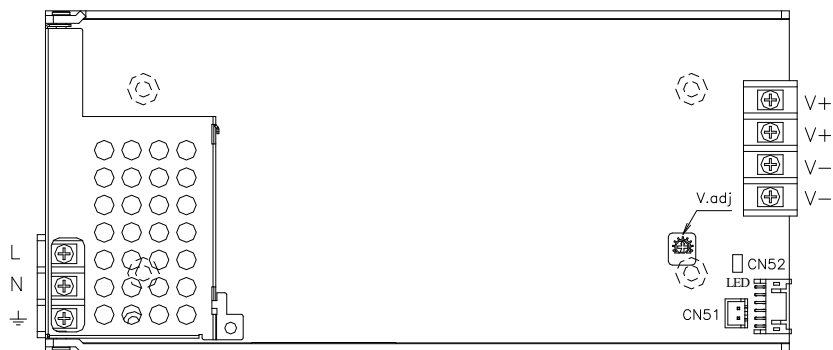

- ① L : Input terminal Live line (fuse in line.), M3 screw.
- ② N : Input terminal Neutral line (fuse in line.), M3 screw.
- ③ \perp : Earth terminal M3 screw.
- ④ V.adj: Output voltage adjustment trimmer. The output voltage rises when the trimmer is turned clockwise.
- ⑤ V+ : + Output Terminal, (20A max./terminal, M3 screw.)
- ⑥ V- : - Output Terminal, (20A max./terminal, M3 screw.)
- ⑦ LED : Output monitoring indicator (SMD type, Green color).

2-2. CN51 Connector pin Configuration and Function

CN51	Pin No.	Configuration	Function
	1	Fan Supply +	+ 12V, 0.3A max. for fan supply etc.
	2	Fan Supply -	Return of fan supply

2-3. CN52 Connector pin Configuration and Function

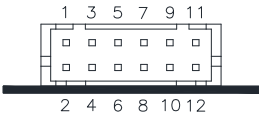
CN52	Pin No.	Configuration	Function
	1	STBY +	+5V, 0.5A max. for standby mode power
	2	STBY -	Return of standby mode power
	3	NC	NO CONNECTION
	4	NC	NO CONNECTION
	5	R-	Remote ON/OFF control terminal -
	6	R+	Remote ON/OFF control terminal +
	7	PG-	Return of power good terminal
	8	PG+	Power good terminal
	9	NC	NO CONNECTION
	10	TOVP	OVP test terminal(only for internal test)
	11	S-	Remote sensing terminal for -output terminal
	12	S+	Remote sensing terminal for +output terminal

*CN51, CN52 Connector & Housing & Terminal Pin

Connector build in PSU	Mated Housing	Mated Terminal Pin	Manufacturer
B2B-XH-A (CN51)	XHP-2 (CN51)	SXH-002T-P0.6 (CN51)	JST
S12B-PHDSS (CN52)	PHDR-12VS (CN52)	SPHD-002T-P0.5 (CN52)	JST

Hand Crimping Tool: YRS-480(SXH-002T-P0.6) (CN51) (JST) and YRS-620(SPHD-002T-P0.5) (CN52)(JST)

Use maker recommended crimping tool.

3. Block Diagram

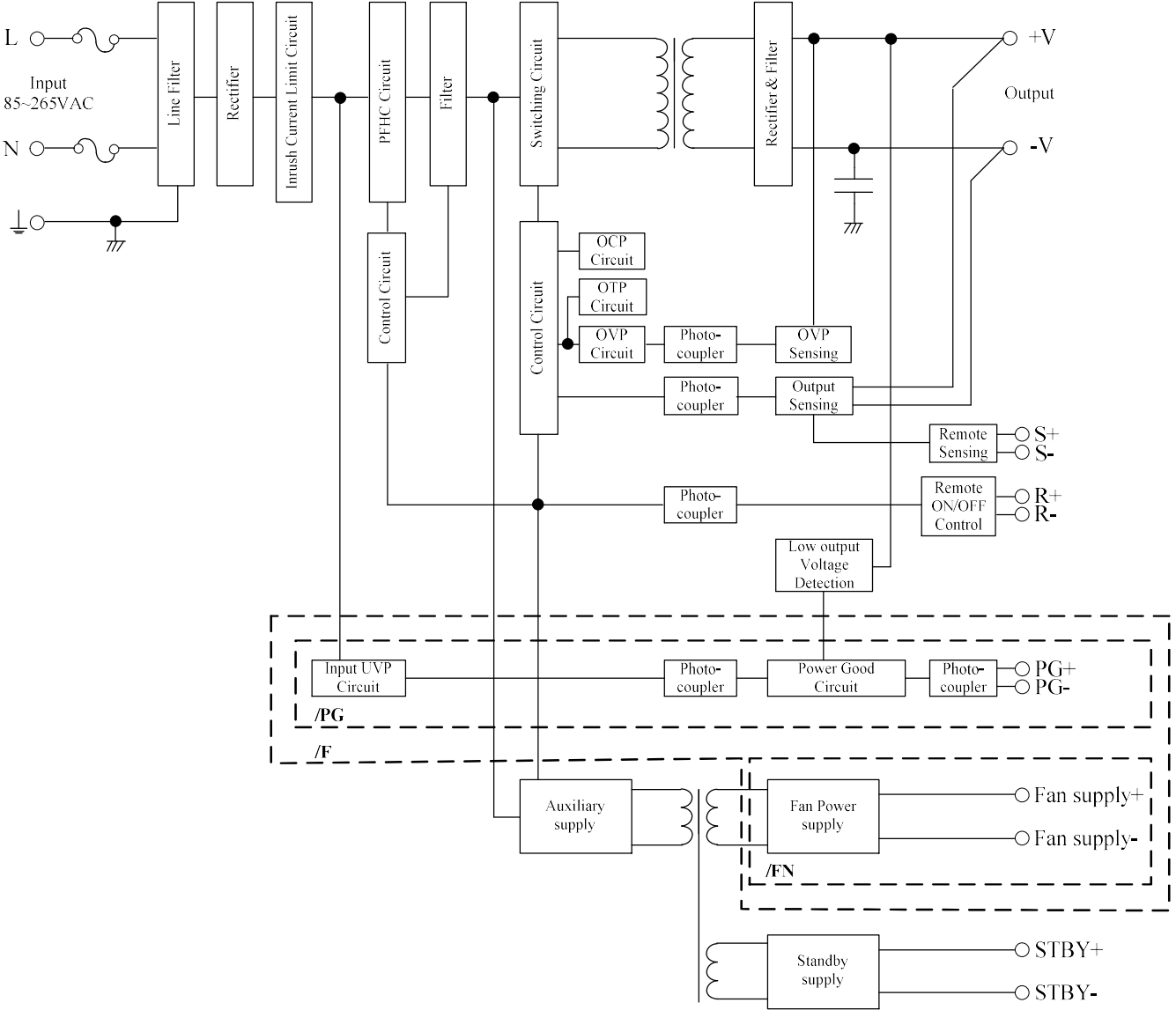

- Fuse rating : 6.3A
- Circuit topology , switching frequency
 - PFHC circuit : active filter (Constant Current Mode) 90~110kHz (frequency jitter)
 - LLC resonant circuit : 50~180kHz
 - Auxiliary supply circuit : 100kHz

4. Sequence time chart

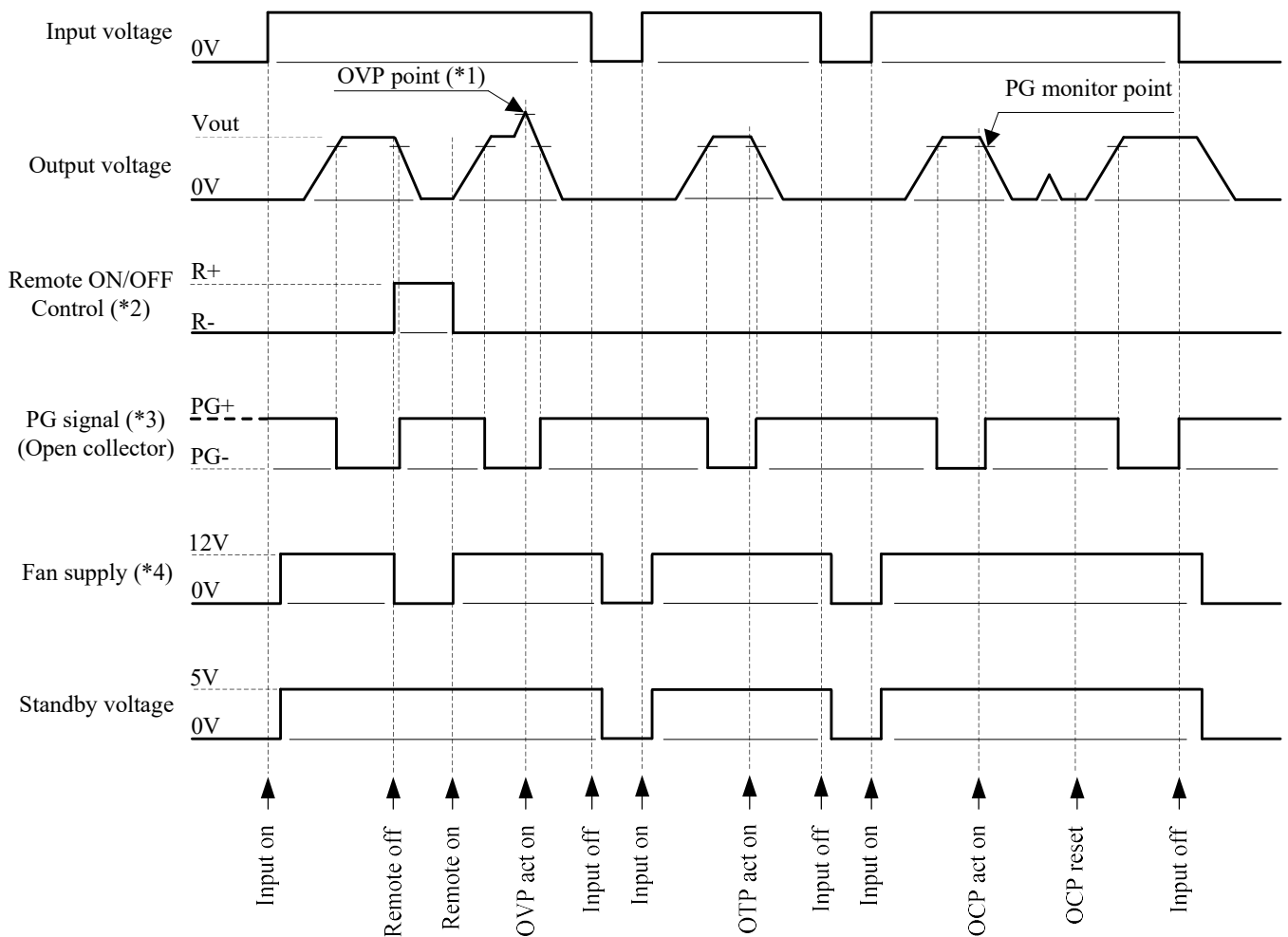

(*1) OVP sensing point : 115%~135%
Please refer specification for detail OVP point.

(*2) Target option : /F, /FN, /PG
Level
Higher than 4.5V : Output off
Lower than 0.5V : Output on
This sequence is using external voltage.

(*3) Target option : /F, /PG

(*4) Target option : /F, /FN

5. Connection Method

Please pay attention to the input wiring. If it is connected to wrong terminal, the power supply will be damaged.

- Input must be off when making connections.
- Connect ⏏ terminal to earth (frame ground of the equipment etc.) by thick wire for safety and improvement of noise sensitivity.
- The output load line and input line shall be separated to improve noise sensitivity.
- Remote sensing lines shall be twisted or used shielded wires.
- Remote ON/OFF control lines shall be twisted or used shielded wires.
- Output current of each terminal pin of CUS350M Series must be less than 20A.



Recommended torque: M3 screw 0.49N · m (5.0kgf · cm)

6. Explanation of Function and Precautions

6-1. Input Voltage Range

Input voltage range is single phase 85-265VAC (47-63Hz). Input voltage, which is out of specification, might lead unit damage. For cases where conformance to various safety requirements, described as 100-240VAC (50-60Hz). If input voltage is less than 115VAC under convection cooling condition or 100VAC under forced air cooling condition, output power need to be derated.

Derating curve of the input voltage

OUTPUT DERATING VERSUS INPUT VOLTAGE

INPUT VOLTAGE (VAC)	LOAD (%)	
	Convection cooling	Forced air cooling
85	80	90
115-265	100	100

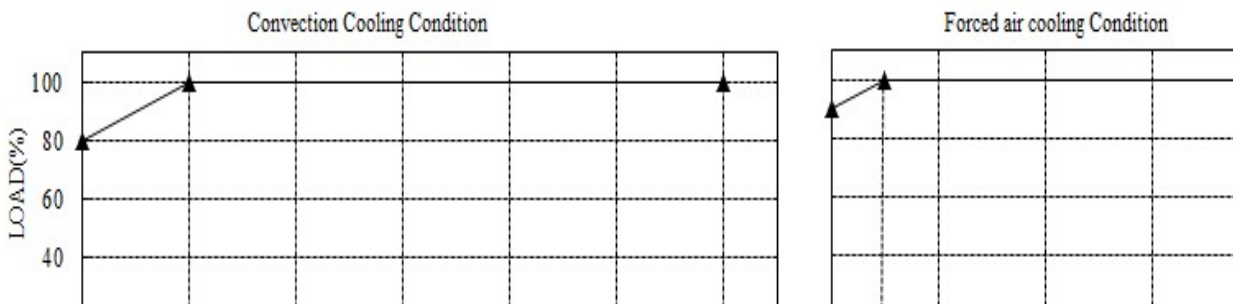

6-2. Output Voltage Range

Output voltage is set at nominal value at shipment. V.adj trimmer (V.adj) can adjust the output voltage within the range. Output voltage range is within $\pm 5\%$ of nominal output voltage. Turn the trimmer clockwise, the output voltage will be increased. Take note when the output voltage is increased excessively, over voltage protection (OVP) function may trigger and output will be shut down. Furthermore, when increasing the output voltage reduce the output current so as not to exceed the maximum output power.

6-3. Inrush Current

These products equipped Power Thermistor to limit the inrush current. Higher inrush current will flow at higher ambient temperature or re-input condition. Please select input switch and fuse carefully with the high temperature and re-input the power condition. The Inrush Current value is under cold start at 25°C in the specification.

6-4. Over Voltage Protection (OVP)

The OVP function (PSU shut down method, manual reset type) is provided. Please refer to its specification for OVP operating range. When OVP trigger, the output will be shut down. To reset OVP, remove the input of power supply for few minutes, and then re-input. In addition, the setting value of OVP is fixed and not adjustable. Pay attention not to apply higher voltage externally to the output terminal to avoid unit failure. In case of inductive load, put protective diode in series to the output power line.

Two methods to recovery from OVP:

- Turn off the input of power supply for a few minutes, and then turn on.
- Remote OFF, and then remote ON again.(Refer to 6-8)

6-5. Over Current Protection (OCP)

CUS350M Series provide the hiccup mode with automatic recovery. OCP function operates when the output current exceeds 105% of maximum DC output current of specification. The output will be automatically recovered when the overload condition is removed. Never operate the unit under over current or shorted conditions for more than 30seconds, which may lead damage or failure. OCP setting is fixed and not to be adjusted externally.

6-6. Over Temperature Protection (OTP)

The OTP function (manual reset type) is provided. When ambient or internal temperature rises abnormally, OTP function operates and output will be shut down. After shut down, remove the input and cool it down to reset OTP, and then re-input.

6-7. Power Good (ALM)

Power Good is an opto coupler providing a minimum 5ms warning before loss of output voltage since AC fail (available only with /F, /PG models). The signal is fully isolated and the maximum sink current 2mA, maximum voltage 20V.

Examples of connecting Power Good are shown as below.

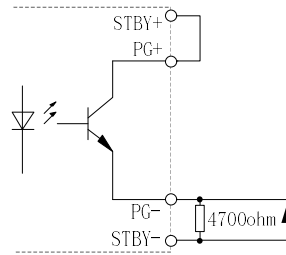
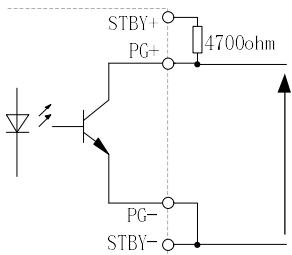

Standard Logic 0

Transistor On (<0.8V) : Power good (DC output is good)
 Transistor Off (>4.5V) : Power not good (AC or DC is not good)
 Actual Test Waveform:

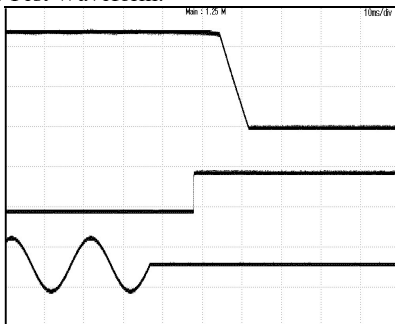

Standard Logic 1

Transistor On (>4.5V) : Power good (DC output is good)
 Transistor Off (<0.8V) : Power not good (AC or DC is not good)

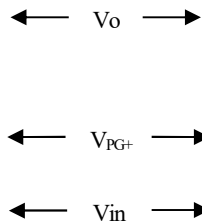
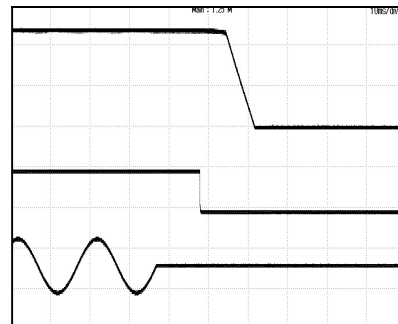

6-8. Remote ON/OFF Control

Remote ON/OFF control is an isolated control signal input which turns the power supply off by supplying 5mA to 10mA into the pin. Remote ON/OFF control enable option available, see the below configuration.

- 1) The current limit resistor need be available when the supply voltage is higher than 5V.
- 2) A switch, relay or a transistor, can be used as ON/OFF switch.

Examples of connecting remote ON/OFF control application:.



Actual Test Waveform (limit resistor is 0ohm) :

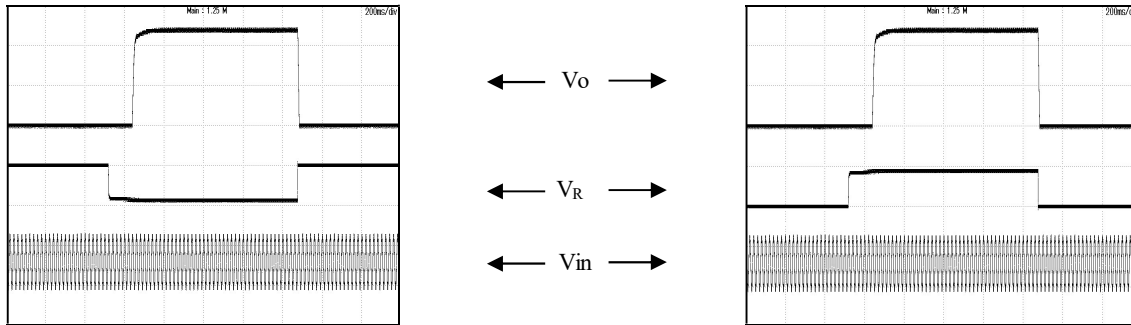

6-9. Remote Sensing (S+, S- terminal)

This function compensates voltage drop of wiring from output terminals to load terminals. Connect “S+” terminal to “+” terminal of load and “S-” to “-” terminal of load with sensing wires. The total line voltage drop (+ side line and - side line) shall be less than 0.5V. Otherwise the output voltage will decrease as the line voltage drop increased. In case that sensing lines are too long, it is necessary to put an electrolytic capacitor in following places.

- 1) Across the load terminal;
- 2) Between “S+” terminal and “V+” terminal;
- 3) Between “S-” terminal and “V-” terminal.

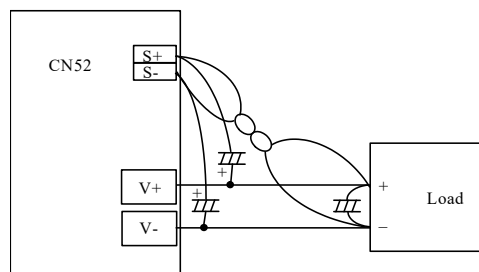

6-10. Output Ripple and Noise

Ripple and noise are measured at 100MHz by using a 150mm twisted pair terminated with a 0.1uF & 100uF capacitor. When load cables are longer, ripple will becomes larger. In this case, electrolytic capacitor, film capacitor, etc. might be necessary to use across the load terminal. The output ripple cannot be measured accurately if the probe ground lead of oscilloscope is too long. For start up at low ambient temperature, output ripple noise might not meet specification. However, output ripple noise specification can be met after few seconds.

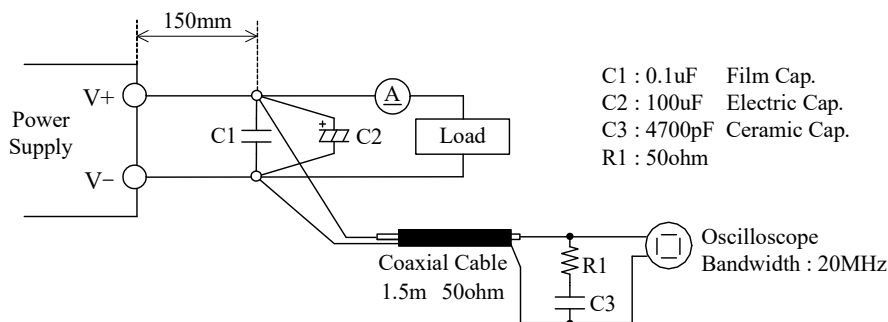

6-11. Series Operation

For series operation, either method (A) or (B) is possible.

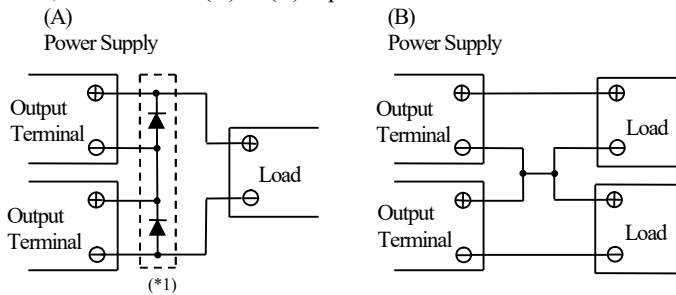

(*1) Please select a bypass diode with maximum forward current rating more than output load current. And maximum reverse voltage must withstand each power supply output voltage.

6-12. Parallel Operation

No current balance function, not recommend.

6-13. Isolation Test

Isolation resistance between Output – FG is more than 100MΩ at 500VDC. For safety operation, voltage setting of DC isolation tester must be done before the test. Ensure that the unit is fully discharged after the test.

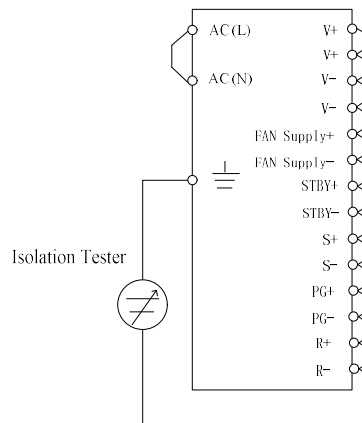

6-14. Withstand Voltage

This series is designed to withstand 4.0kVAC between input and output, 1.5kVAC between input and FG and 1.5kVAC between output and FG each for 1 minute. When testing withstands voltage, set current limit of the withstand voltage test equipment to 20mA. The applied voltage must be gradually increased from zero to the testing value and then gradually decreased for shut down. When timer is used, the power supply may be damaged by high impulse voltage at timer switch on and off. Connect input and output as follows.

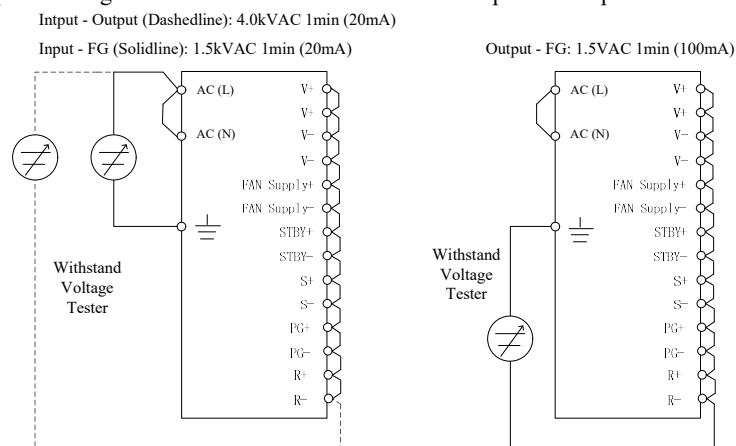

6-15. Auxiliary Supply

Auxiliary supplies - FAN Supply (available only with option models) : 12V/0.3A , Standby Mode Power: 5V/0.5A, are provided to ease customer application. FAN Supply 12V can be used to drive customer system fan. Standby Mode Power 5V can be used as customer system power supply. Standby Mode Power is always available as long as input power is present. The Fan supply (optional) is controlled by Remote ON/OFF control.

7. Mounting Directions

7-1. Output Derating according to the Mounting Directions

Recommended standard mounting method is (A), Method (B, C, D, E) are also possible. Refer to the output derating below. Load (%) of derating curve indicates output power. The E-cap life under Method D and Method E maybe be shorter than 3years, the detail please see the official data.

(A) Standard mounting

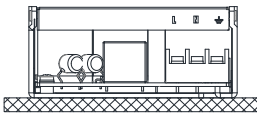

(B)

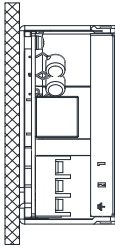

(C)

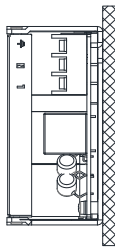

(D)

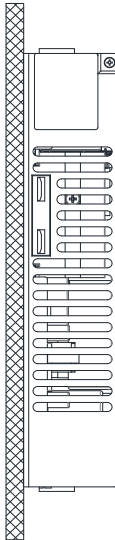

(E)

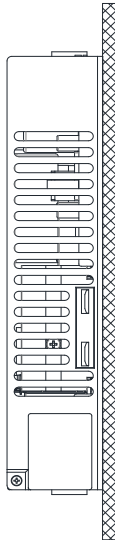

Inhibit

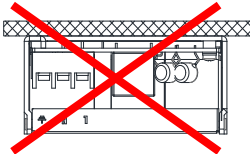

7-2. Output Derating vs. Ambient temperature

Make sure that the specified temperature range is maintained.

Ta (°C)	LOAD (%) Convection cooling	LOAD (%) Forced air cooling
-20 - +40	100	100
50	83	100
60	67	75
70	50	50

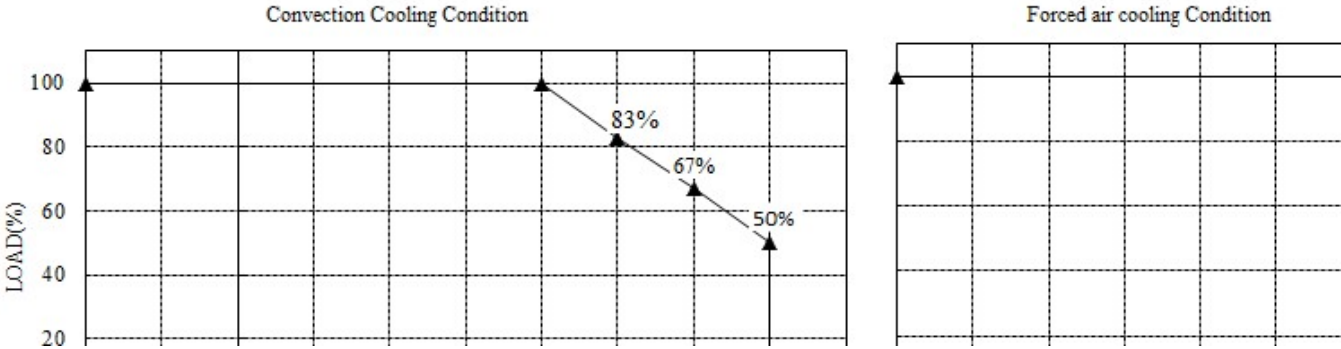

Forced air cooling condition:

Minimum air velocity: 1.5m/s (Measured at components side of PCB, air must flow through component side)

7-3. Mounting Method

- (1) The maximum allowable penetration for screw into chassis is 4mm.
- (2) Recommended torque for mounting screw: M4 screw, 1.27N·m (13kgf·cm).
- (3) Metal plate with minimum 1.5mm thickness is recommended as mounting plate.
- (4) Keep enough space in the power supply surroundings and the upper area of component for convection cooling, as a reference for reliable thermal design, keep the temperature of Heat Sink lower than 110 °C at Test Point below. the safety space requirement please refer to the related standard.

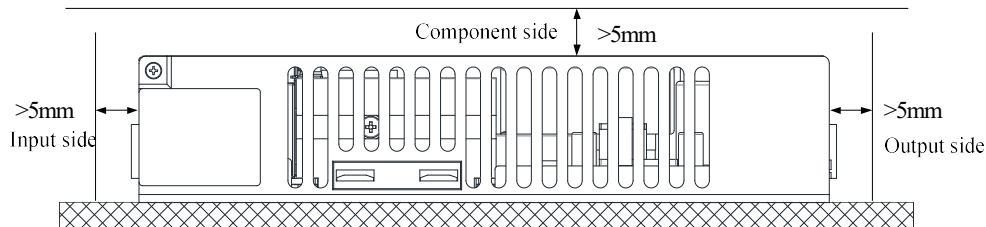

- (5) Rear mounting from bottom side with 4*M4 screws is recommended to comply the vibration and shock specification. Recommended torque for the Mounting screw: M4 screws, 1.27N·m (13.0kgf·cm).
- (6) Recommend to connect mounting hole to protective ground of system

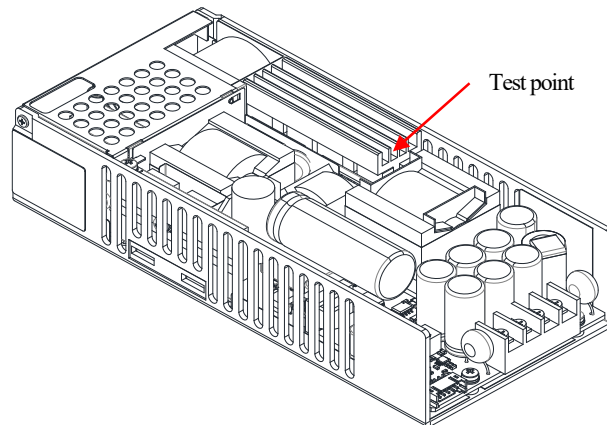

8. Wiring Method

- (1) The output and input cables shall be separated each other and twisted individually to improve noise sensitivity.
- (2) Use all cables as thick and short as possible to made lower impedance.
- (3) Noise can be reduced by attaching a capacitor to the load terminals.
- (4) For safety and EMI considerations, connect between \ominus terminal of input connector and Protective Earth terminal of equipment firmly.
- (5) Recommended torque for the terminal: M3 screw, 0.49N·m (5.0kgf·cm).

9. External Fuse Rating

Refer to the following fuse rating when selecting the external fuses that are to be used on input line. Surge current flows when line turns on. Have to use slow-blow or time-lag type fuse, not fast-blow fuse. Fuse rating is considered by in-rush current value at line turn-on. Do not select the fuse according to input current (RMS.) values under the actual load condition.

CUS350M Series: 6.3A

10. Before concluding that the unit is at fault

- (1) Check if the rated input voltage is connected.
- (2) Check if the wiring of input and output is correct.
- (3) Check if the wire thickness is enough.
- (4) Check if the output current and output wattage dose not over specification.
- (5) Check if the output voltage control (Vadj) is properly adjusted. OVP might be triggered and output is shut down.
- (6) Check if the Remote ON/OFF control circuit is connected correctly.
- (7) Check if OTP is triggered. Please re-input to cool down the unit sufficiently.
- (8) Audible noise can be heard when input voltage waveform is not sinusoidal wave.
- (9) Audible noise can be heard during Dynamic-Load operation.
- (10) Ensure that a large capacitor is not connected across the output terminals. Please use within maximum capacitance shown below.

Model	CUS350M-12	CUS350M -18	CUS350M -24	CUS350M -48
Maximum external capacitance	12000uF	9000uF	2700uF	270uF

11. Altitude

CUS350M is safety approved for operation at below altitude.

-Up to 5000m by IEC62368-1 clearance requirement.

-Up to 4000m by IEC60601-1 clearance requirement.

Thermal evaluation should be considered for products operating at elevated altitudes above 2000m.

12. The life expectancy

The life of the power supply depends on the life of the built-in aluminum electrolytic capacitor. The life is described in reliability data. The life of the aluminum electrolytic capacitor varies depending on the method of mounting the power supply, the load current, and the ambient temperature. Please refer to “Electrolytic Capacitor Lifetime” .

Please do not use the product which passed over the life expectancy. There is a risk of unexpected output shutdown and specifications may not be satisfied.

Please contact us for maintenance or exchange the product which passed over the life expectancy.

13. Warranty Period

CUS350M is safety approved for operation at below altitude.

This product is warranted for a period of 3 years from the date of shipment.

For damages occurring at normal operation within this warranty period, repair is free of charge.

Please read the General Safety Instruction before using the products.

3 years warranty applies but not limited to the following.

(1) Average operating temperature (ambient temperature of the power supply unit)is under 40°C.

(2) 3 years warranty base on 24 hours/day operation at 100% load.

Please refer to electrolytic capacitor life time from reliability data for various application conditions such as mounting, load derating, operating ambient temperature etc.

Customer system design could be improved with better electrolytic capacitor life time by selecting proper application method.

Following cases are not covered by warranty.

(1) Improper usage like dropping products, applying shock and defects from operation exceeding specification of the units.

(2) Defects resulting from natural disaster (fire, flood etc.).

(3) Unauthorized modifications or repair.

14. CE MARKING / UKCA MARKING

CE MARKING

CE Marking, when applied to a product or packing material for a product covered by this handbook, indicates compliance with the Low Voltage Directive, EMC Directive and RoHS Directive.

UKCA MARKING

UKCA Marking, when applied to a product or packing material for a product covered by this handbook, indicates compliance with the Electrical Equipment (Safety) Regulations, Electromagnetic Compatibility Regulations and Restriction of the Use of Certain Hazardous Substances in Electrical & Electronic Equipment Regulations.