

CUS500M1

Instruction Manual

BEFORE USING THE POWER SUPPLY UNIT

Be sure to read this instruction manual thoroughly before using this product. Pay attention to all cautions and warnings before using this product. Incorrect usage could lead to an electrical shock, damage to the unit or a fire hazard.

DANGER

Never use this product in locations where flammable gas or ignitable substances are present.

INSTALLATION WARNING

- When installing, ensure that work is done in accordance with the instruction manual. When installation is improper, there is risk of electric shock and fire.
- Installation shall be done by Service personnel with necessary and appropriate technical training and experience. There is a risk of electric shock and fire.
- Do not cover the product with cloth or paper etc. Do not place anything flammable around. This might cause damage, electric shock or fire.

WARNING on USE

- Do not touch this product or its internal components while circuit in operation, or shortly after shutdown. You may receive a burn.
- While this product is operating, keep your hands and face away from it as you may be injured by an unexpected situation.
- For products with no cover, do not touch them as there are high-voltage and high temperature parts inside. Touching them might cause injury such as electric shock or burn.
- There are cases where high voltage charge remains inside the product. Therefore, do not touch even if they are not in operation as you might get injured due to high voltage and high temperature. You might also get electric shock or burn.
- Do not make unauthorized changes to this product nor remove the cover as you might get an electric shock or might damage the product. We will not be held responsible after the product has been modified, changed or dis-assembled.
- Do not use this product under unusual condition such as emission of smoke or abnormal smell and sound etc. Please stop using it immediately and shut off the product. It might lead to fire and electric shock. In such cases, please contact us. Do not attempt repair by yourself, as it is dangerous for the user.
- Do not operate and store these products in environments where condensation occurs due to moisture and humidity. It might lead fire and electric shock.
- Do not drop or apply shock to this product. It might cause failure. Do not operate these products, when mechanical stress is applied.

CAUTION on MOUNTING

- Confirm connections to input/output terminals are correct as indicated in the instruction manual before switching on.
- Input /Output line, please use the wires as short and thick as possible.
- Do not use this product in special environment with strong electromagnetic field, corrosive gas or conductive substances and direct sunlight, or places where product is exposed to water or rain.
- Mount this product properly in accordance with the instruction manual, mounting direction and shall be properly be ventilated.
- Please shut down the input when connecting input and output of the product.
- When installing in environment where conductive foreign, dust and liquid may be present, please consider penetration of above foreign material in the power supply by installing filter, to prevent trouble or malfunction.

 **CAUTION on USE**

- Product individual notes are shown in the instruction manual. If there is any difference with common notes individual notes shall have priority.
- Before using this product, be sure to read the catalog and instruction manual. There is risk of electric shock or damage to the product or fire due to improper use.
- Input voltage, Output current, Output power, ambient temperature and ambient humidity should be kept within specifications, otherwise the product will be damaged, or cause electric shock or fire.
- If the built-in fuse is blown, do not use the product even after replacing the fuse, as there is risk of abnormality inside. Be sure to request repair to our company.
- For products without built-in protection circuit (element, fuse, etc.), insert fuse at the input to prevent smoke, fire during abnormal operation. As for products with built-in protection circuit, depending on usage conditions, built-in protection circuit might not work. It is recommended to provide separate proper protection circuit.
- For externally mounted fuse do not use other fuses aside from our specified and recommended fuse.
- This product was made for general purpose electronic equipment use and is not designed for applications requiring high safety (such as extremely high reliability and safety requirements. Even though high reliability and safety are not required, this product should not be used directly for applications that have serious risk for life and physical safety. Take sufficient consideration in fail-safe design (such as providing protective circuit or protective device inside the system, providing redundant circuit to ensure no instability when single device failure occurs).
- When used in environments with strong electromagnetic field, there is possibility of product damage due to malfunction.
- When used in environment with corrosive gas (hydrogen sulfide, sulfur dioxide, etc.) , there is possibility that they might penetrate the product and lead to failure.
- When used in environments where there is conductive foreign matter or dust, there is possibility of product failure or malfunction.
- Provide countermeasure for prevention of lightning surge voltage as there is risk of damage due to abnormal voltage.
- Connect together the frame ground terminal of the product and the ground terminal of the equipment for safety and noise reduction. If these ground is not connected together, there is risk of electric shock.
- Parts with lifetime specifications (built-in fan electrolytic capacitor) are required to be replaced periodically. Set the overhaul period depending on the environment of usage and perform maintenance. Also, note that there are cases when EOL products cannot be overhauled.
- Take care not to apply external abnormal voltage to the output. Especially, applying reverse voltage or overvoltage more than the rated voltage to the output might cause failure, electric shock or fire.
- Take care not to apply mechanical stress on surface mounted components otherwise causing failure for power supply.
- This product has possibility that hazardous voltage might occur in output terminal depending on failure mode. The output of these products must be protected in the end use equipment to maintain SELV.
- For product with built-in fan, do not block the air intake and exhaust as this might lead to fire

 **General installation instructions**

- These products are optional for installation in Class I or Class II end equipment, and for Class I must be reliably earthed and professionally installed, for Class II no earth connection to the power supply is required.
- These products are IPX0, and therefore chemicals/solvents, cleaning agents and other liquids must not be used.
- The first protective earth connection in the final installation must be marked with the protective earth symbol.

Special Instructions for IEC/EN/ES/CSA 60601-1

- These products are designed for continuous operation within an overall enclosure, and must be mounted such that access to the mains terminals is restricted. See Clause 16, IEC/60601-1 2nd edition or clause 8 IEC/EN/ES/CSA 60601-1 3rd edition.
- These products are NOT suitable for use in the presence of flammable anesthetics mixtures with air or with oxygen or with nitrous oxide.
- These products are classed as ordinary equipment according to IEC/EN/ES/CSA60601-1 and are NOT protected against the ingress of water.
- Reference should be made to local regulations concerning the disposal of these products at out of their useful life.
- These products have not been assessed to IEC/EN60601-1-2 (EMC) but EMC test data is available from TDK-Lambda Corporation.
- For IEC 60601-1 2nd Edition, these products have a reinforced insulation barrier between input and output. For IEC/EN/ES/CSA 60601-1 3rd edition, these products provide reinforced insulation between input and outputs of 2 MOPP, 1 MOPP from input to earth and 1 MOPP from output to earth.
- These products have SELV outputs.
- All outputs have basic spacing's to earth rated for mains – 250Vac, and due consideration must be given to this in the end product design.

Important safety instructions

- **Servicing**

These products are not customer serviceable. Repairs may only be carried out by TDK-Lambda Corporation or their authorized agents. These products are not authorized for use as critical components in nuclear control systems, life support systems or equipment for use in hazardous environments without the express written approval of the Managing Director of TDK-Lambda Corporation.

- **Safety Class of Protection**

These products are designed for the following parameters: Material Group IIIb, Pollution Degree 2, Over voltage Category II, class I (earthed)
Indoor use as part of an overall equipment such that the product is accessible to service engineers only.

EMC performance

- Immunity (IEC61000-6-2)

Test	Standard
Electrostatic discharge	IEC61000-4-2
Electromagnetic field	IEC61000-4-3
Fast / burst transient	IEC61000-4-4
Surge immunity	IEC61000-4-5
Conducted RF immunity	IEC61000-4-6
Power frequency magnetic field	IEC61000-4-8
Voltage dips, variations, interruptions	IEC61000-4-11

- Emissions

Test	Standard	Comments
Radiated electric field	EN55032	Class B (as per CISPR 32)
Conducted emissions	EN55032	Class B (as per CISPR 32)
Conducted harmonics	IEC61000-3-2	Compliant
Flicker	IEC61000-3-3	Compliant

NOTE

- Take note that traces of sheet metal processing be left in our power supplies.
- When disposing product, follow disposal laws of each municipality.
- Published EMI (CE, RE) or immunity is the result when measured in our standard measurement conditions and might not satisfy specification when mounted and wired inside end-user equipment. Use the product after sufficiently evaluating at actual end-user equipment.
- When exporting our products, apply for necessary permissions as required by rules and regulations of Foreign Exchange and Foreign Trade Control Act.
- Catalogue, contents of the instruction manual may be changed without a prior notice. Refer to latest catalogue or instruction manual.
- Reproduction or reprinting the instruction manual or its portion is forbidden without our permission.

LONG-TERM STORAGE METHOD AND LONG-TERM STORAGE PERIOD

- Please keep the product in carton box.
- Please do not apply excessive vibration, shock or mechanical stress applied directly to the product.
- Please keep away from direct sunlight.
- For long-term storage temperature and humidity, the following conditions shall be used as a guideline:

Temperature range : 5°C ~ 30°C

Humidity range : 40% ~ 60%RH

Please keep away from the places where temperature and humidity can change drastically. It can cause condensation on the product or deterioration.

- For long-term storage period, we recommend to use within 2 years after receiving the product.
 - < Soldering and PCB mounted products: On Board, Power Module and etc >
 - For products that have been received for more than 1 year, please check lead oxidation and solderability.
 - In addition, SMD type products may have MSL (Moisture Sensitivity Level) provision.
 - Please be sure to read the instruction manual and delivery specifications.
 - < Unit type or PCB type of products: the product is used an aluminum electrolytic capacitor >
 - There is tendency that the leakage current of an aluminum electrolytic capacitor may increase when stored without using for a long time. This phenomenon can be improved by applying voltage to the aluminum electrolytic capacitor to reduce the increased leakage current through the self-recovery effect of the electrolyte. For reference, before using products that have been stored for a very long time, please warm-up first for 30 minutes or more without taking load.
 - < Criterion of warm up voltage condition >
 - (1) Implementation period: 1 year or above after the delivery.
 - (2) Electrical continuity condition.
 - Input voltage: Rating.
 - Load: 0A.
 - Ambient temperature: Normal temperature.
 - Time: 30 minutes or more.

1. Model name identification method

CUS 500M1 – 12 / □

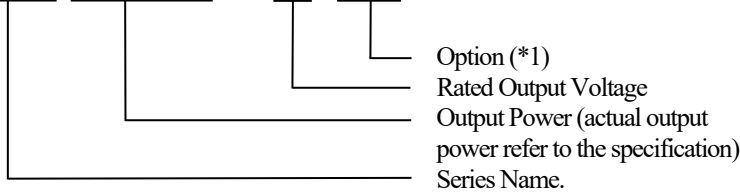

(*1) Blank : Standard type.
 / SF : Single fuse model.
 / EF : End fan model.

Note : For “/EF” model , please refer to instruction manual of CUS500M1/EF.

2. Terminal Explanation

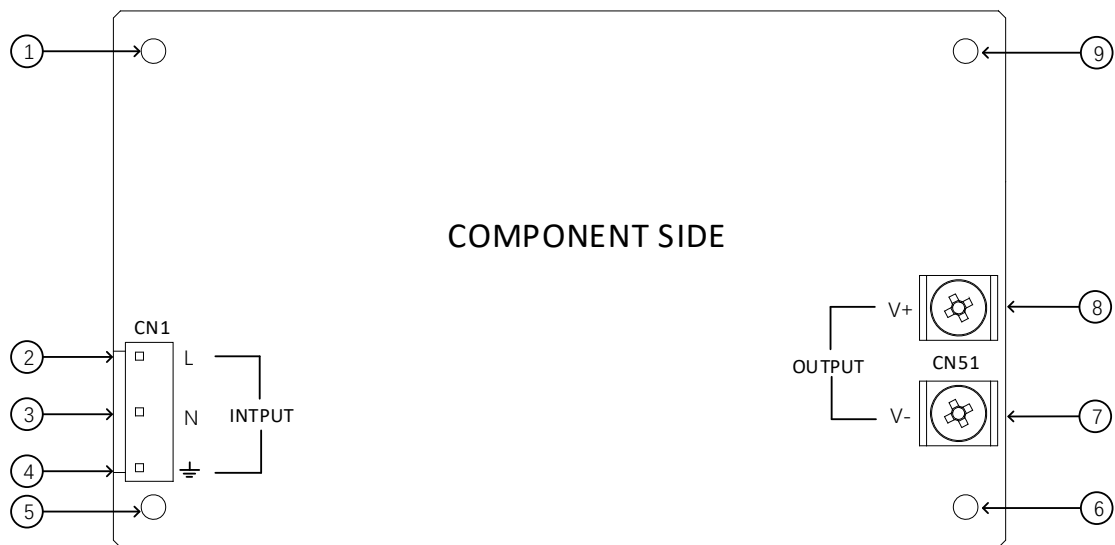

- ① Mounting hole (hole diameter : ϕ 3.5mm), This hole is not connected to functional earth of CN1. The mounting surface of the spacer should be within Max 7mm.
- ② L : Input terminal Live line (Fuse in line.).
- ③ N : Input terminal Neutral line (Fuse in line.).
- ④ \perp : Functional earth terminal.
- ⑤ Mounting hole (hole diameter : ϕ 3.5mm), This hole is connected to functional earth of CN1. The mounting surface of the spacer should be within Max ϕ 7mm.
- ⑥ Mounting hole (hole diameter : ϕ 3.5mm). For Class I end equipment, this hole should be connected to ⑤ to improve EMC characteristics. For Class II end equipment, this hole can't be connected to ⑤.
- ⑦ V-: - Output Terminal.
- ⑧ V+: + Output Terminal.
- ⑨ Same as mounting hole ①.

***CN1,CN51 Connector & Housing & Terminal Pin**

	Connector	Housing	Terminal Pin	Maker
Input (CN1)	B3P5-VH(LF)(SN)	VHR-5N	SVH-41T-P1.1	JST
Output (CN51)	M4 terminals	—	—	—

Hand Crimping Tool : YC-930R(JST).

Use maker recommended crimping tool.

Housing and terminal pin are not included in product.

Recommended torque for M4 screws of CN51 : 1.18N·M(12kgf·cm)MAX.

3. Block Diagram

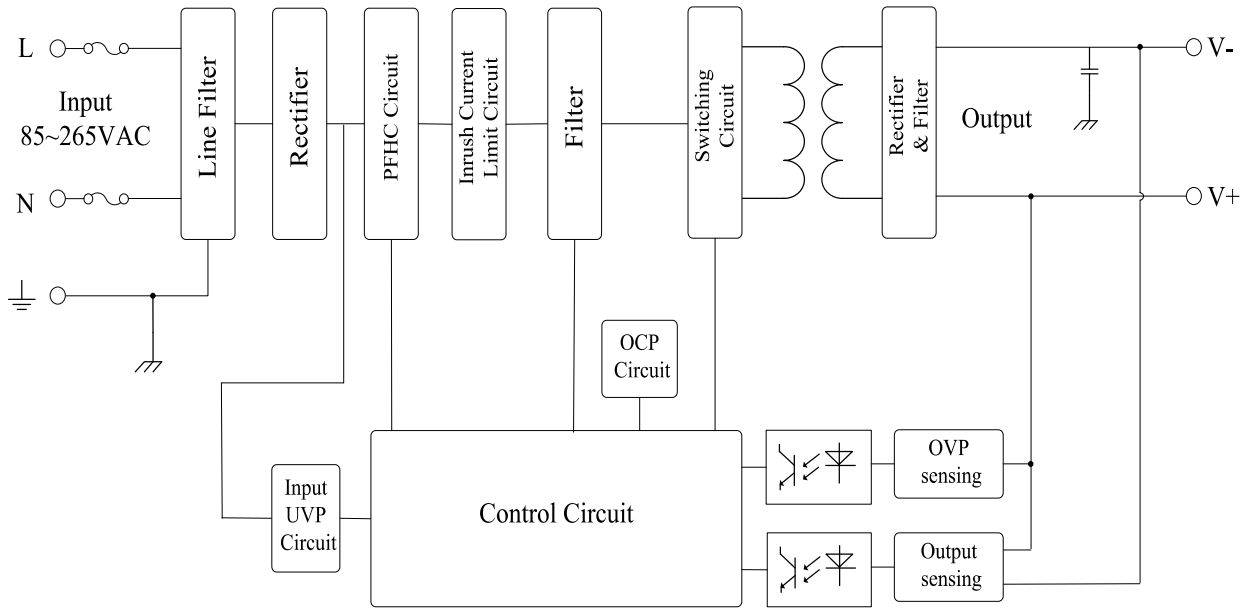

● Fuse rating : 10A

● Circuit topology, switch frequency
PFHC circuit: active filter 65kHz (Typ).
Output circuit: LLC resonant 45k~280kHz.

4. Sequence time chart

Input voltage ON/OFF and output OVP recovery sequence time chart

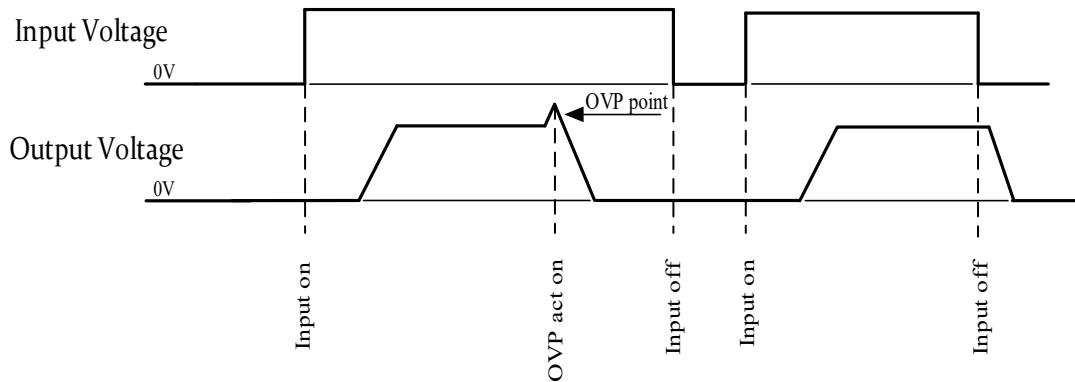

Output OCP (latch and not latched) recovery sequence time chart

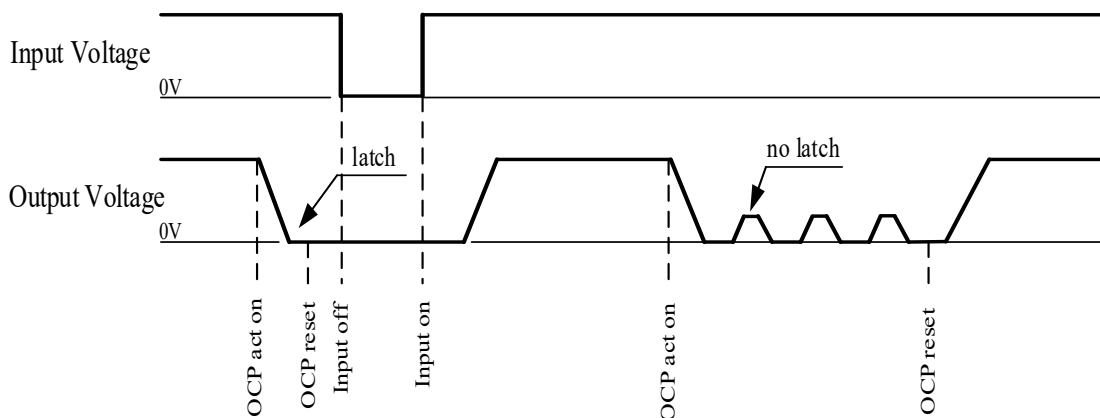

5. Connection Method

Pay attention to the input wiring. If it is connected to wrong terminal, the power supply may be damaged.

- Input must be off when making connections.
- For Class I end equipment, connect \perp terminal of mounting hole and input connector to protective earth of the equipment.
- For Class II end equipment, mounting hole ⑤ and ⑥ can't be connected together.
- The output load line and input line shall be separated to improve noise sensitivity.
- Do not apply stress to PCB, when connecting or removing connectors.
- Do not apply stress to the components when connecting or removing connectors.

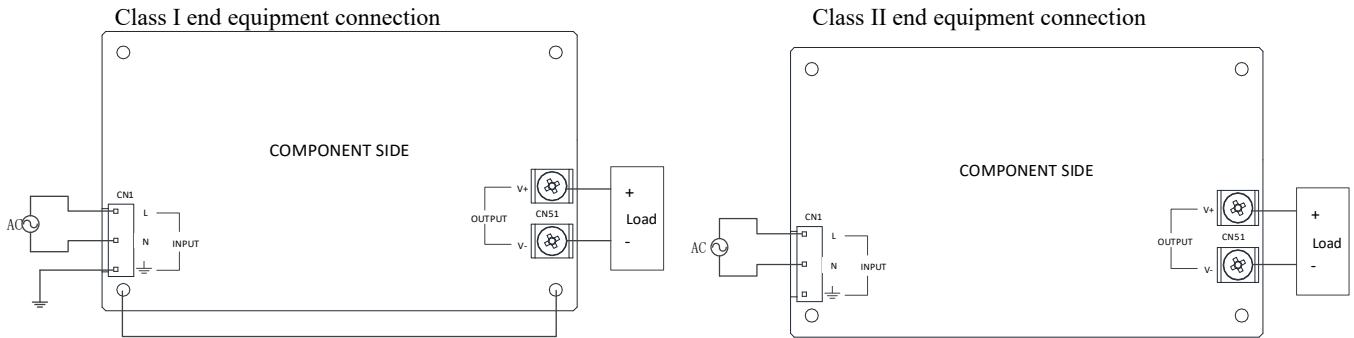

6. Explanation of Function and Precautions

6-1. Input Voltage Range

Input voltage range is single phase 85-265VAC(47-63Hz). Input voltage, which is out of specification, might lead unit damage. For cases where conformance to various safeties required, described as 100-240VAC (50-60Hz). If input voltage is less than 115VAC, output power need to be derated.

Derating curve of the input voltage

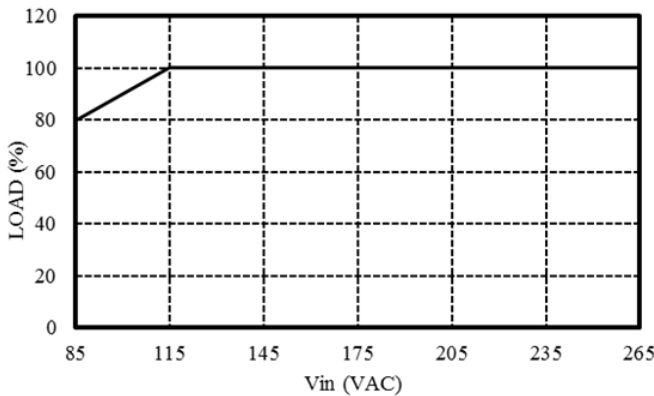

INPUT VOLTAGE (VAC)	MOUNTING A,B,C,D,E
	LOAD (%)
85	80
115~265	100

6-2. Output Voltage Range

Output voltage is set the rated value at shipment.

6-3. Inrush Current

These products equipped power thermistor to limit the inrush current. Higher current will flow at higher ambient temperature or re-input condition. Please select input switch and fuse carefully with the high temperature and re-input the power condition. The inrush current value is under cold start at 25°C in the specification.

6-4. Over Voltage Protection (OVP)

The OVP function (Inverter shut down method, manual reset type) is provided. Please refer to its specification for OVP range. When OVP triggers, the output will be shut down. In addition, the setting value of OVP is fixed and not adjustable. To recovery from OVP, turn off the input of power supply for a few minutes, and then re-input. Pay attention not to apply higher voltage externally to the output terminal to avoid unit failure. In case of inductive load, put protective diode in series to the output power line.

6-5. Over Temperature Protection (OTP)

Over temperature shut down function is provided.

When ambient or internal temperature rises abnormally, over temperature protection function operates and output will be shut down. After shut down, remove the input and cool it down to reset over temperature protection, and then re-input.

Over temperature protection function operates at out of the specification area.

This function may not activate or cannot avoid power supply damage depending on the situation.

6-6. Over Current Protection (OCP)

These products provide the Hiccup mode with automatic recovery. OCP function operates when the output current exceeds 105% of maximum DC output current at forced air cooling of specification. The outputs will be automatically recovered when the overload condition is canceled, however the outputs may be latched off when shorted condition happens. Never operate the unit under over current or shorted conditions, which may lead damage or insulation failure. OCP setting is fixed and not to be adjusted externally.

6-7. Output Ripple & Noise

The standard specification for maximum ripple value is measured according to measurement circuit specified as below. When load lines are longer, ripple will become larger. In this case, electrolytic capacitor, film capacitor, etc. might be necessary to use across the load terminal. The output ripple cannot be measured accurately if the probe ground lead of oscilloscope is too long.

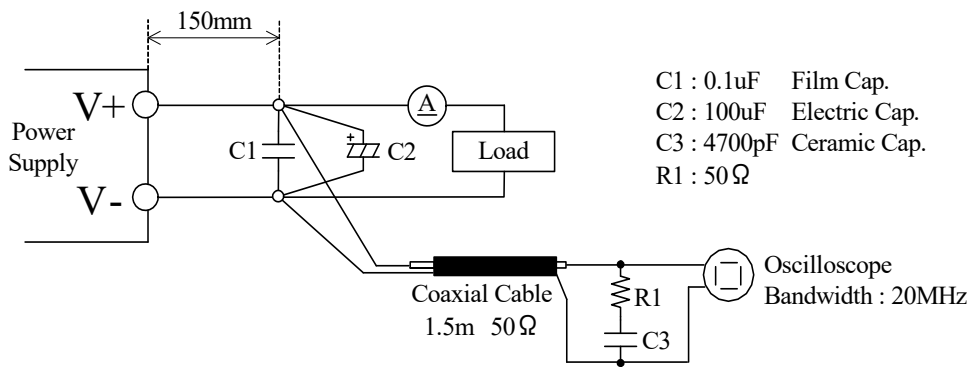

6-8. Series Operation

For series operation, either method (A) or (B) is possible.

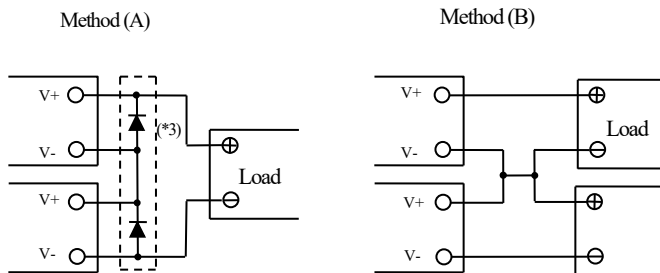

Note: In case of (A), please select a bypass diode (*3) with maximum forward current rating more than output load current. And maximum reverse voltage must withstand each power supply output voltage.

Never use when one of the unit not operate, which may lead damage.

6-9. Parallel Operation

For parallel operation, method (B) is possible

(A) To increase the output current is not possible.

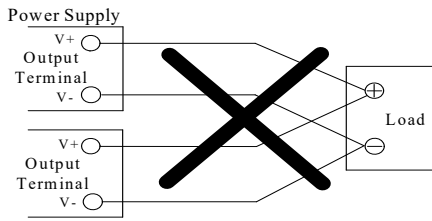

(B) To use as Back-up Power Supply

1. Adjust the output voltage of each power supply to be the same.
 2. Set power supply output voltage higher by the forward voltage drop (V_f) of diode.
- Use within the specification for output voltage and output power.

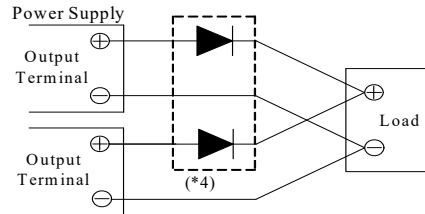

(*4) Please select a reverse current prevention diode with maximum forward current rating more than output load current

6-10. Isolation Test

Isolation resistance between Output and \perp is more than 100M Ω at 500VDC. For safety operation, voltage setting of DC isolation tester must be done before the test. Ensure that the unit is fully discharged after the test.

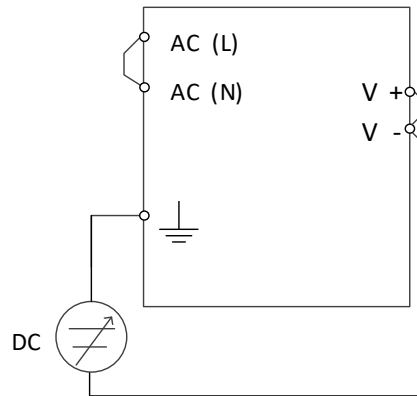

6-11. Withstand Voltage Test

These products are designed to withstand 4.0kVAC between input and output, 2.0kVAC between input and \perp and 1.5kVAC between output and \perp for 1 minute. When testing withstand voltage, set current limit of the withstand voltage test equipment to 20mA. The applied voltage must be gradually increased from zero to the testing value and then gradually decreased for shut down. When timer is used, the power supply may be damaged by high impulse voltage at timer switch on and off. Connect input and output as follows.

Input – Output (Dashed line): 4kVAC, 1 minute (20mA)

Input – \perp (Solid line) : 2kVAC, 1 minute (20mA)

Output – \perp : 1.5kVAC 1 minute (20mA)

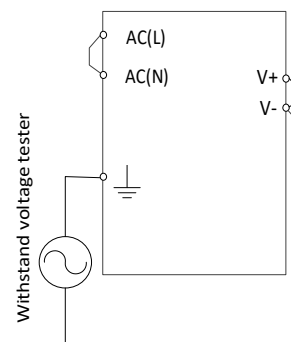
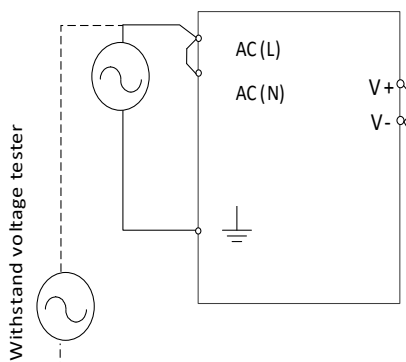

Note : In case of using external noise filter, capacitance between “Input and \perp ” might be increased. When testing withstand voltage between “Input and Output”, there is a possibility exceeding withstand voltage between “Output and \perp ” (1.5kVAC). Please check the voltage between “Output and \perp ”. If the voltage exceeding withstand voltage, please add external capacitor to “Output and \perp ”. It can decrease the voltage.

On the other hand, no need to check the voltage in case of “Output and \perp ” is shorted.

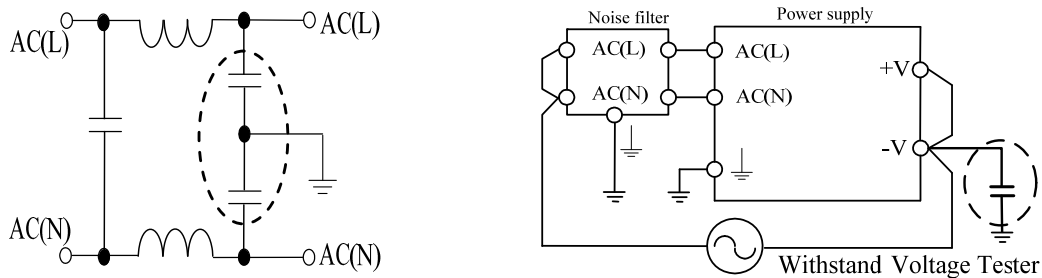

7. Mounting Directions

7-1. Output Derating according to the Mounting Direction

Recommended standard mounting direction is (A). Mounting direction (B)-(E) are also possible. Refer to the output derating below. Load (%) of derating curve indicates output power.

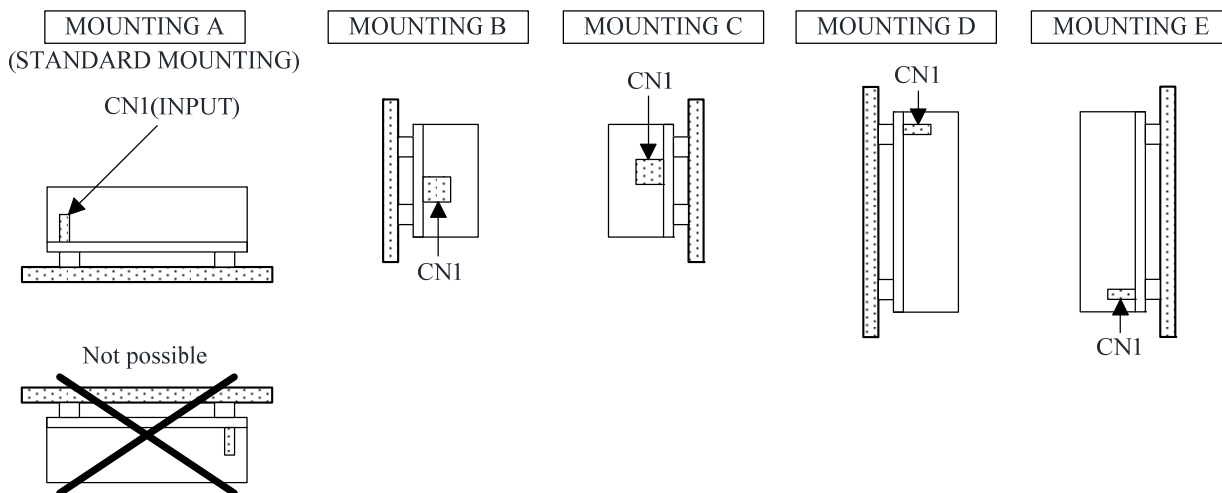

7-2. Output Derating

Make sure that the specified temperature range is maintained.

Convection cooling @ universal input

CONDITION: Output derating versus input voltage should be considered.
 Please refer to the output derating versus input voltage curve 6-1 for detail.

MODEL: CUS500M1-12/19/24/28/32/36/48

Ta (°C)	Mounting A B C E	Mounting D
	LOAD (%)	LOAD (%)
-20 - +35	100	100
40	100	91.4
50	83.3	74.3
60	66.7	57.1
70	50	40

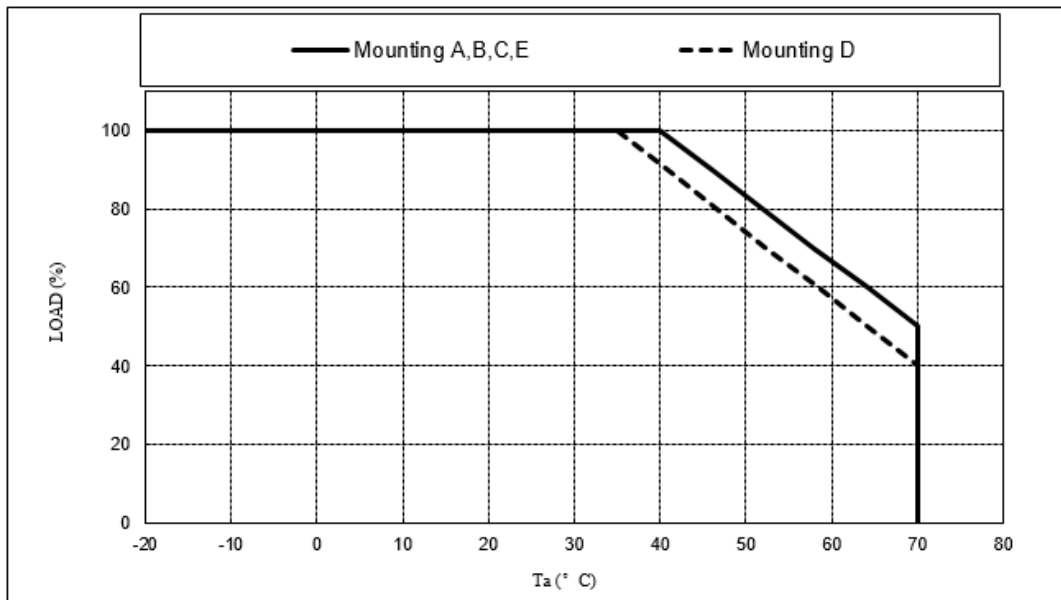

FORCED AIR COOLING @ UNIVERSAL INPUT (85-265Vac)

CONDITION: Forced air cooling with air velocity more than 2.7m/s, measured at component side,
 The entire components must be cooled.
 Output derating versus input voltage should be considered.
 Please refer to the output derating versus input voltage curve 6-1 for detail.

AIR FLOW DIRECTION

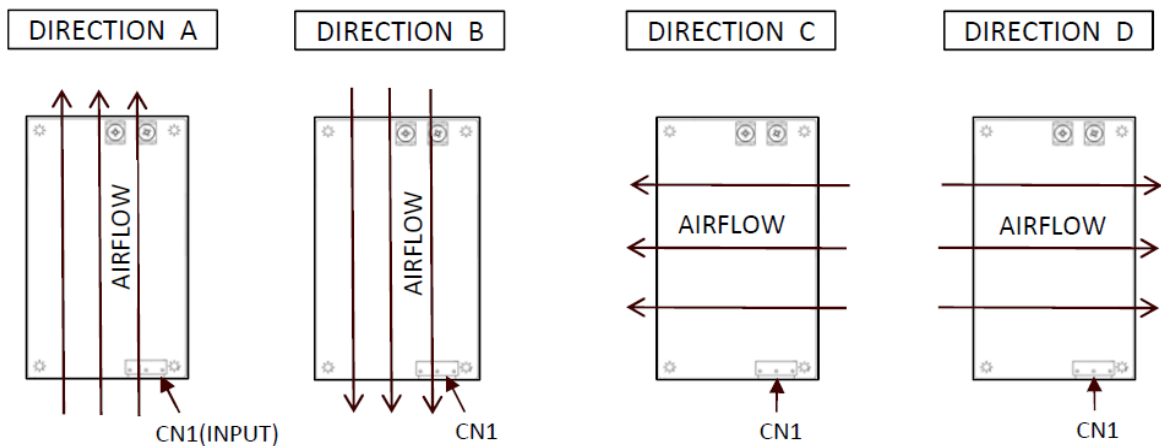

MODEL: CUS500M1-19/24/28/32/36/48

Ta (°C)	Direction A D	Direction B	Direction C
	LOAD (%)	LOAD (%)	LOAD (%)
-20 - +45	100	100	100
50	94	100	100
60	82	90	100
70	70	80	80

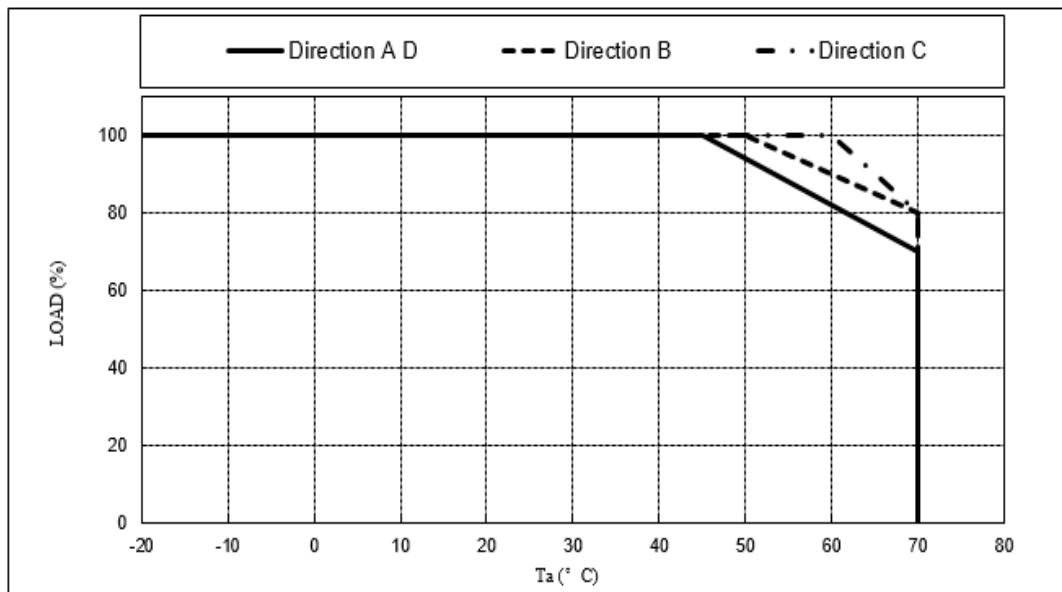

MODEL: CUS500M1-12

Ta (°C)	Direction A	Direction B	Direction C	Direction D
	LOAD (%)	LOAD (%)	LOAD (%)	LOAD (%)
-20 - +30	90	100	100	90
40	82.5	100	100	90
45	78.8	100	100	90
50	75	100	100	86
60	67.5	90	100	78
70	60	80	80	70

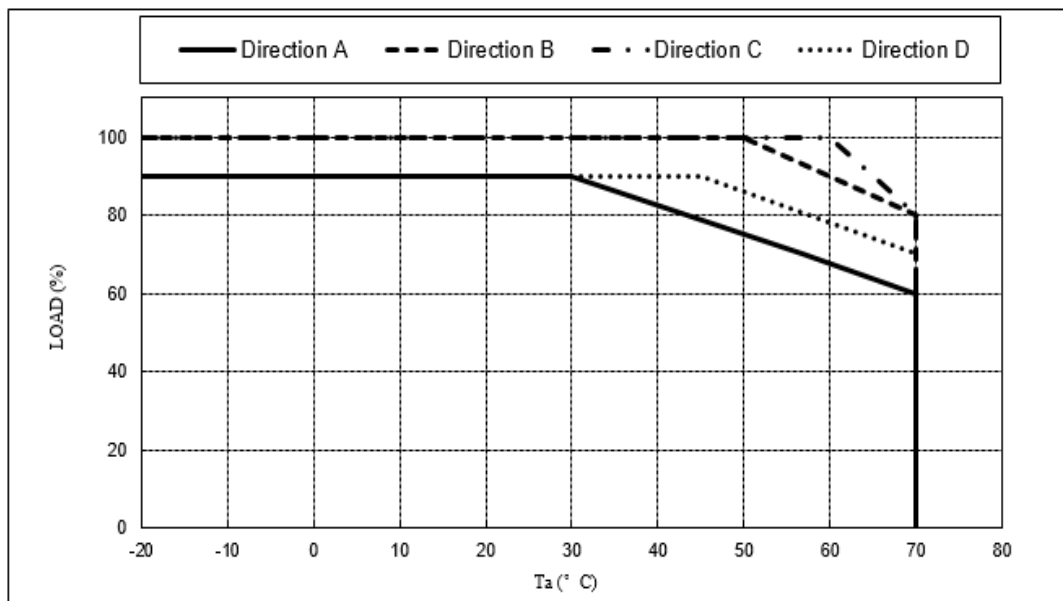

Peak output power @ Convection cooling

Peak output power is acceptable in any condition if the components listed in the following table must not exceed the temperatures given. To determine the component temperatures the heating tests must be conducted in accordance with the requirements of the standard in question. Consideration should also be given to the requirements of other safety standards. Test requirements include: PSU to be fitted in its end-use equipment and operated under the most adverse conditions permitted in the end-use equipment handbook/specification and which will result in the highest temperatures in the PSU. To determine the most adverse conditions consideration should be given to the end use equipment maximum operating ambient, the PSU loading and input voltage, ventilation, end use equipment orientation, the position of doors & covers etc. Temperatures should be monitored using type K fine wire thermocouples (secured with cyanoacrylate adhesive or similar) placed on the hottest part of the component (out of any direct airflow) and the equipment should be run until all temperatures have stabilized.

Below is typical application:

Peak output power up to 7 seconds at convection cooling is allowed. For peak output power using, the RMS power should not be higher than the Maximum Output Power @ Convection cooling (load derating versus Input voltage, Operating temperature and Mounting position should be considered).

RMS power is calculated using the following formula:

$$\text{RMS power} = ((\text{peakpower}^2 \times T1 + \text{reducedpower}^2 \times T2) / (T1 + T2))^{1/2}$$

Where T1 = peak power time on in seconds.
T2 = reduced power time on in seconds.

Circuit Ref.	Description	Max. Temperature (°C)
CN1	Input Connector	105
C1	X Capacitor	110
L2	Common Mode Choke Winding	120
C5,C52	Y Capacitor	125
BD1	Bridge Diode	130
L4	Boost Choke Winding	130
C6	Boost Capacitor	90 (*5)
Q1	Boost FET	125
T1	Main Transformer Winding	130
T2	Standby Transformer Winding	130
PC101,PC103	Opto-Coupler	110
C51A,C51B,C51C, C51D,(C51E),C51F	Electrolytic Capacitors	100 (*5)

Note : (*5) Please also evaluate electrolytic capacitors life before using

7-3. Mounting Method

Insert the spacer (Max ϕ 7mm) of height more than 8mm to lift the unit. And use all mounting holes for the unit installation. The vibration spec is specified under this mounting condition. Keep enough space in the power supply surroundings and the upper area of components for convection cooling.

- (1) Mounting Holes size: 4 holes ϕ 3.5mm.

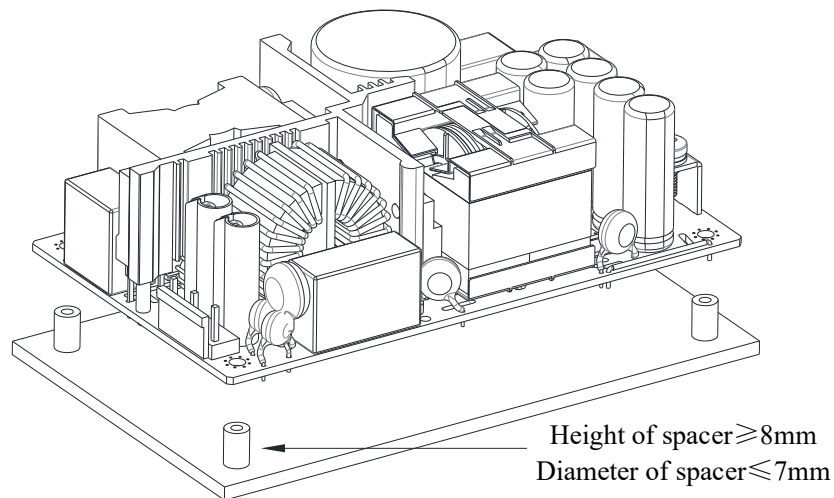

Allowable area touched by metal pieces are 9mm from each PCB corners.

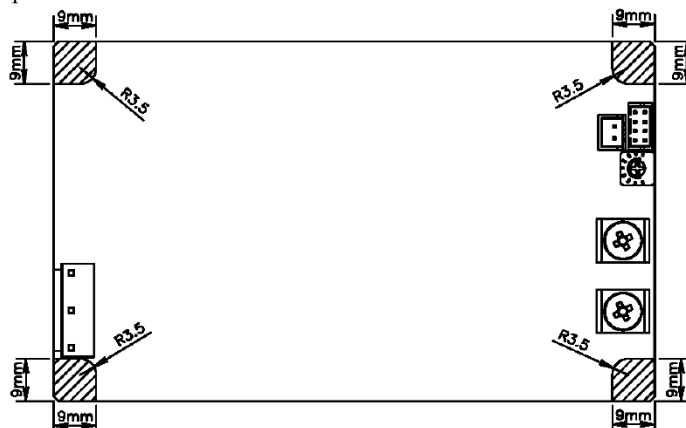

- (2) Conditions to meet Isolation and Withstanding Voltage standard.
 Keep 5mm space from the surfaces and sides of PCB. Especially, 8mm space is necessary from the solder surface. If the space is not enough, the specification of isolation or withstanding voltage will not be satisfied.

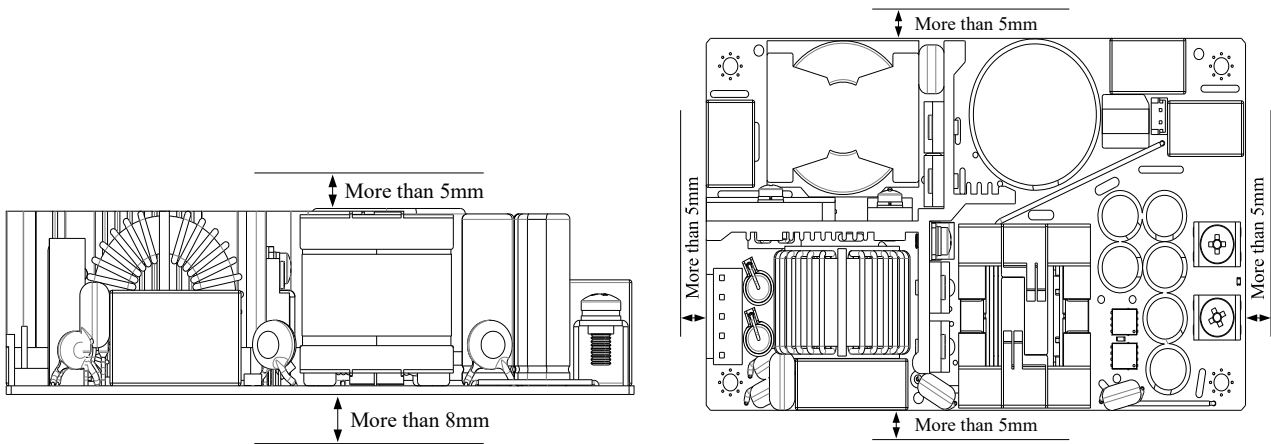

- (3) For Class I end equipment, \perp (Functional Earth) should be connected to the earth terminal of the equipment. Also the mounting hole are should be connected to the Chassis by metal spacer. If not, the conducted noise, radiation noise and output noise may increase. Please refer to below setup.

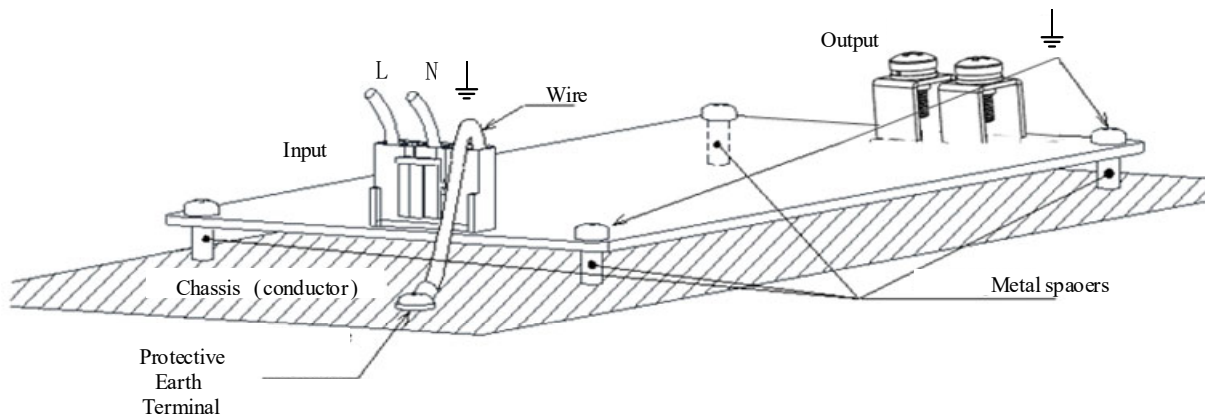

- (4) For Class II end equipment, \perp (Functional Earth) can't be connected, All mounting holes are should be connected to the Chassis by insulated spacer. This power supply is also suitable for Class II application, however please countermeasure EMC performance before using.

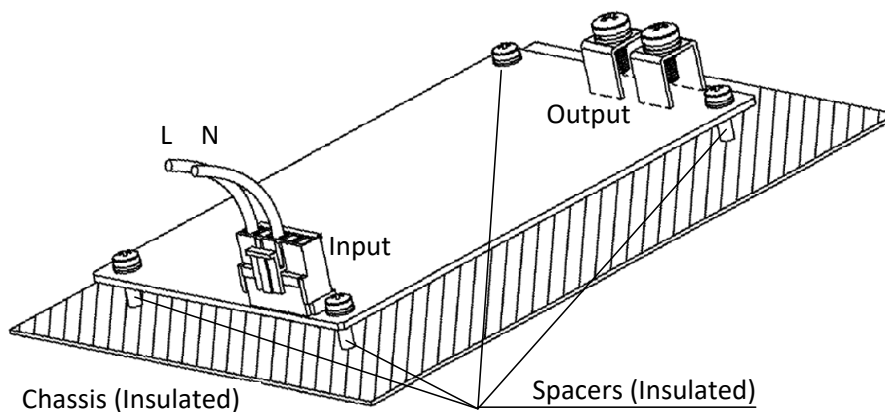

8. Wiring Method

- (1) The output load line and input line shall be separated each other and twisted individually to improve noise.
- (2) Use all lines as thick and short as possible to made lower impedance.
- (3) Noise can be reduced by attaching a capacitor to the load terminals.
- (4) For safety and EMI considerations, connect \perp with the terminal of protective earth of equipment firmly.
- (5) Select the wire materials to the JST connector as follows.
Input wire : AWG#18~AWG#16

9. The life expectancy

The life of the power supply depends on the life of the built-in aluminum electrolytic capacitor. The life is described in reliability data. The life of the aluminum electrolytic capacitor varies depending on the method of mounting the power supply, the load current, and the ambient temperature. Please refer to "Electrolytic Capacitor Lifetime".

Please do not use the product which passed over the life expectancy. There is a risk of unexpected output shutdown and specifications may not be satisfied.

Please contact us for maintenance or exchange the product which passed over the life expectancy.

10. External Fuse Rating

Refer to the following fuse rating when selecting the external fuses that are to be used on input line. Surge current flows when line turns on. Have to use slow-blow or time-lag type fuse, not fast-blow fuse. Fuse rating is considered by in-rush current value at line turn-on. Do not select the fuse according to input current (RMS.) values under the actual load condition.

CUS500M1 series: 10A

11. Before concluding that the unit is at fault

- (1) Check if the rated input voltage is connected.
- (2) Check if the wiring of input and output is correct.
- (3) Check if the wire thickness is enough.
- (4) Check if the output current and output wattage dose not over specification.
- (5) Audible noise can be heard when input voltage waveform is not sinusoidal wave.
- (6) Audible noise can be heard during Dynamic-Load operation.
- (7) Ensure that a large capacitor is not connected across the output terminals. Please use within maximum capacitance shown below.

Model	CUS500M1-12	CUS500M1-19	CUS500M1-24	CUS500M1-28	CUS500M1-32	CUS500M1-36	CUS500M1-48
Maximum external capacitance	10000uF	10000uF	8000uF	4000uF	3000uF	3000uF	2500uF

12. Warranty Period

The warranty period applies for below conditions.

$T_a \leq 40^\circ\text{C}$

Mounting direction:(A)

Cooling: convection cooling

For damages occurring at normal operation within this warranty period, repair is free of charge.

For other mounting directions inquire to TDK-Lambda.

Following cases are not covered by warranty

- (1) Improper usage like dropping products, applying shock and defects from operation exceeding specification of the unit.
- (2) Defects resulting from natural disaster (fire, flood etc.)
- (3) Unauthorized modifications or repair.
- (4) Condition of continuously dynamic load or AC power on/off

13. Altitude

CUS500M1 is safety approved for operation at below altitude.

- Up to 5000m by IEC62368-1 clearance requirement.

- Up to 5000m by IEC60601-1 clearance requirement.

Thermal evaluation should be considered for products operating at elevated altitudes above 2000m.

14.CE MARKING/ UKCA MARKING

CE MARKING

CE Marking, when applied to a product or packing material for a product covered by this handbook, indicates compliance with the Low Voltage Directive, EMC Directive and RoHS Directive.

UKCA MARKING

UKCA Marking, when applied to a product or packing material for a product covered by this handbook, indicates compliance with the Electrical Equipment (Safety) Regulations, Electromagnetic Compatibility Regulations and Restriction of the Use of Certain Hazardous Substances in Electrical & Electronic Equipment Regulations.