

CUT35

Instruction Manual

BEFORE USING THE POWER SUPPLY UNIT

Be sure to read this instruction manual thoroughly before using this product. Pay attention to all cautions and warnings before using this product. Incorrect usage could lead to an electrical shock, damage to the unit or a fire hazard.

DANGER

- Never use this product in locations where flammable gas or ignitable substances are present.

INSTALLATION WARNING

- When installing, ensure that work is done in accordance with the instruction manual. When installation is improper, there is risk of electric shock and fire.
- Installation shall be done by Service personnel with necessary and appropriate technical training and experience. There is a risk of electric shock and fire.
- Do not cover the product with cloth or paper etc. Do not place anything flammable around. This might cause damage, electric shock or fire.

WARNING on USE

- Do not touch this product or its internal components while circuit in operation, or shortly after shutdown. You may receive a burn.
- While this product is operating, keep your hands and face away from it as you may be injured by an unexpected situation.
- For products with no cover, do not touch them as there are high-voltage and high temperature parts inside. Touching them might cause injury such as electric shock or burn.
- There are cases where high voltage charge remains inside the product. Therefore, do not touch even if they are not in operation as you might get injured due to high voltage and high temperature. You might also get electric shock or burn.
- Do not make unauthorized changes to this product nor remove the cover as you might get an electric shock or might damage the product. We will not be held responsible after the product has been modified, changed or dis-assembled.
- Do not use this product under unusual condition such as emission of smoke or abnormal smell and sound etc. Please stop using it immediately and shut off the product. It might lead to fire and electric shock. In such cases, please contact us. Do not attempt repair by yourself, as it is dangerous for the user.
- Do not operate and store these products in environments where condensation occurs due to moisture and humidity. It might lead fire and electric shock.
- Do not drop or apply shock to this product. It might cause failure. Do not operate these products mechanical stress is applied.

CAUTION on MOUNTING

- Confirm connections to input/output terminals are correct as indicated in the instruction manual before switching on.
- Input voltage, Output current, Output power, ambient temperature and ambient humidity should be kept within specifications, otherwise the product will be damaged.
- Input line, please use the wires as short and thick as possible.
- Do not use this product in special environment with strong electromagnetic field, corrosive gas or conductive substances and direct sunlight, or places where product is exposed to water or rain.
- Mount this product properly in accordance with the instruction manual, mounting direction and shall be properly be ventilated.
- Please shut down the input when connecting input and output of the product.

⚠ CAUTION on USE

- Product individual notes are shown in the instruction manual. If there is any difference with common notes individual notes shall have priority.
- Before using this product, be sure to read the catalog and instruction manual. There is risk of electric shock or damage to the product or fire due to improper use.
- Input voltage, Output current, Output power, ambient temperature and ambient humidity should be kept within specifications, otherwise the product will be damaged, or cause electric shock or fire.
- If the built-in fuse is blown, do not use the product even after replacing the fuse as there is risk of abnormality inside. Be sure to request repair to our company.
- For products without built-in protection circuit (element, fuse, etc.), insert fuse at the input to prevent smoke, fire during abnormal operation. As for products with built-in protection circuit, depending on usage conditions, built-in protection circuit might not work. It is recommended to provide separate proper protection circuit.
- For externally mounted fuse do not use other fuses aside from our specified and recommended fuse.
- This product was made for general purpose electronic equipment for standard industrial use and is not designed for applications requiring high safety (such as extremely high reliability and safety requirements. Even though high reliability and safety are not required, this product should not be used directly for applications that have serious risk for life and physical safety. Take sufficient consideration in fail-safe design (such as providing protective circuit or protective device inside the system, providing redundant circuit to ensure no instability when single device failure occurs).
- When used in environments with strong electromagnetic field, there is possibility of product damage due to malfunction.
- When used in environment with corrosive gas (hydrogen sulfide, sulfur dioxide, etc.), there is possibility that they might penetrate the product and lead to failure.
- When used in environments where there is conductive foreign matter or dust, there is possibility of product failure or malfunction.
- Provide countermeasure for prevention of lightning surge voltage as there is risk of damage due to abnormal voltage.
- Connect together the frame ground terminal of the product and the ground terminal of the equipment for safety and noise reduction. If these ground is not connected together, there is risk of electric shock.
- Parts with lifetime specifications (built-in fan electrolytic capacitor) are required to be replaced periodically. Set the overhaul period depending on the environment of usage and perform maintenance. Also, note that there are cases when EOL products cannot be overhauled.
- Take care not to apply external abnormal voltage to the output. Especially, applying reverse voltage or overvoltage more than the rated voltage to the output might cause failure, electric shock or fire.
- Do not use in special environment such as places directly exposed to sunlight, dew condensation, moisture, rain, strong electro-magnetic field, or corrosive gas (hydrogen sulfide, sulfur dioxide).

⚠ Note

- Take note that traces of sheet metal processing be left in our power supplies.
- Consider storage of the product at normal temperature and humidity avoiding direct exposure to sunlight at environment with minimal temperature and humidity changes. Storage of product at high temperature, high humidity and environments with severe changes in temperature and humidity might cause deterioration, and occurrence of condensation in the product.
- When disposing product, follow disposal laws of each municipality.
- Published EMI (CE, RE) or immunity is the result when measured in our standard measurement conditions and might not satisfy specification when mounted and wired inside end-user equipment. Use the product after sufficiently evaluating at actual end-user equipment.
- When exporting our products, apply for necessary permissions as required by rules and regulations of Foreign Exchange and Foreign Trade Control Act.
- Catalogue, contents of the instruction manual may be changed without a prior notice. Refer to latest catalogue or instruction manual.
- Reproduction or reprinting the instruction manual or its portion is forbidden without our permission.

Important safety instructions

Servicing

These products are not customer serviceable. Repairs can only be carried out by TDK-Lambda or their authorized agents. These products are not authorized for use as critical components in nuclear control systems, life support systems or equipment for use in hazardous environments without the express written approval of the Managing Director of TDK-Lambda Corporation.

Safety Class of Protection

This power supply is a switch mode power supply for use in applications within a Pollution Degree 2, overvoltage category II environment. Material Group IIIb PCB is used within it.

Input markings and symbols

 Caution refer to supplementary documents

EMC performance

Immunity

Test	Standard	Passed	Comments
Electrostatic discharge	IEC61000-4-2	Level 4	Air discharge 15.0kV Contact discharge 8.0kV
Electromagnetic field	IEC61000-4-3	Level 3	10V/m
Fast / burst transient	IEC61000-4-4	Level 4	4.0kV (100kHz)
Surge immunity	IEC61000-4-5	Level 3 Level 4	Normal mode 2.0kV Common mode 4.0kV
Conducted RF immunity	IEC61000-4-6	Level 3	10V
Power frequency magnetic field	IEC61000-4-8	Level 4	30A/m
Voltage dips, variations, interruptions	IEC61000-4-11	Class3	*1,*2,*3,*4

- *1. On the condition of 30% dip and 500ms duration, the output voltage will recover after the power turn on again.
- *2. On the condition of 60% dip and 200ms duration, the output voltage will recover after the power turn on again.
- *3. On the condition of 100% dip and 20ms duration, the output voltage will recover after the power turn on again.
- *4. On the condition of 100% dip and 5000ms duration, the output voltage will recover after the power turn on again.

Emissions

Test	Standard	Comments
EMI	EN55032	Class B (as per CISPR 32)

General installation instructions

- 1) These products are for installation in Class I end equipment only, and therefore must be reliably earthed and professionally installed.
- 2) These products are IPX0, and therefore chemicals/solvents, cleaning agents and other liquids must not be used.
- 3) The first protective earth connection in the final installation must be marked with the protective earth symbol.

Special Instructions for IEC/UL/ 60601-1

- 1) These products are designed for continuous operation within an overall enclosure, and must be mounted such that access to the mains terminals is restricted. See Clause 16, IEC/UL60601-1.
- 2) These products are NOT suitable for use in the presence of flammable anaesthetic mixtures with air or with oxygen or with nitrous oxide.
- 3) These products are classed as ordinary equipment according to IEC/UL60601-1 and are NOT protected against the ingress of water.
- 4) Reference should be made to local regulations concerning the disposal of these products at out of their useful life.
- 5) These products have not been assessed to IEC/UL60601-1-2 (EMC) but EMC test data is available from TDK-Lambda Corporation.
- 6) For IEC/EN 60601-1 3rd Edition, ANSI/AAMI ES 60601-1, CSA 22.2 No 60601-1, these products provide reinforced insulation between input and outputs of 2 MOOPs. 1 MOOP from input to earth and 1 MOOP from output to earth.
- 7) All outputs have basic spacing's to earth rated for mains - 250Vac, and due consideration must be given to this in the end product design.
- 8) These products have SELV outputs.

1. Model name identification method

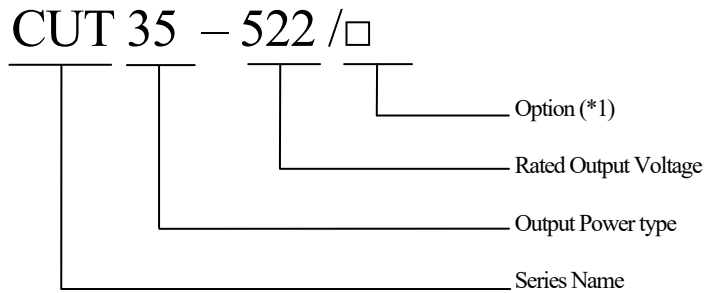

- (*1) Blank : Standard model
 /A : With chassis and cover model
 /L : With chassis model
 /B : With baseplate model

2. Terminal Explanation

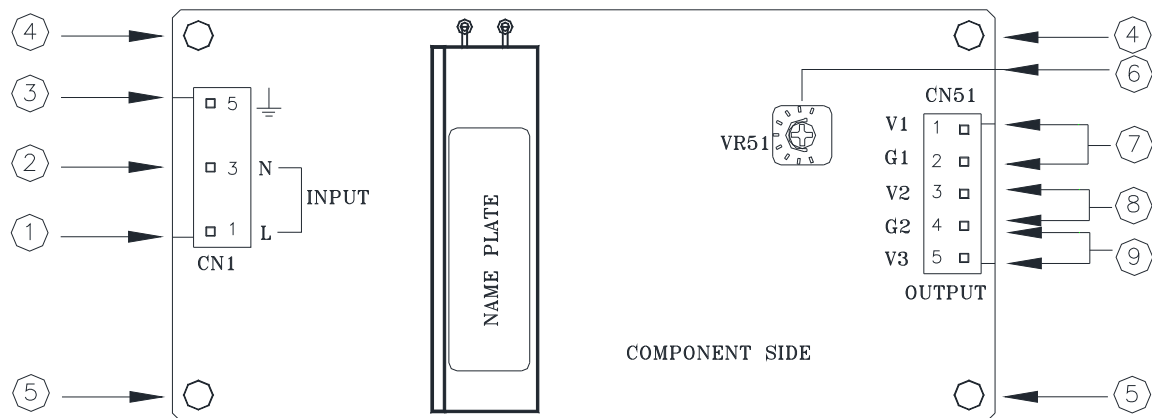

- ① L : AC Input terminal Live line (Fuse in line.)
 ② N : AC Input terminal Neutral line (Fuse in line.)
 ③ \perp : \perp Terminal (Protective Earth)
 ④ Mounting hole (hole diameter : ϕ 3.5mm)
 This hole is electrically connected to Protective earth of CN1.
 ⑤ Mounting hole (hole diameter : ϕ 3.5mm)
 ⑥ V.ADJ : Output voltage adjust trimmer. The output voltage rises when the trimmer is turned clockwise.
 ⑦ CH1
 V1 : CH1 + Output Terminal
 G1 : CH1 - Output Terminal
 ⑧ CH2
 V2 : CH2 + Output Terminal
 G2 : CH2/CH3 Common Ground
 ⑨ CH3
 G2 : CH2/CH3 Common Ground
 V3 : CH3 - Output Terminal

3. Terminal Connection Method

Pay attention to the input wiring. If it is connected to wrong terminal, the power supply will be damaged.

- Input must be off when making connections.
- \perp terminal must be connected to protective earth of the equipment.
- Output current of each terminal pin must be less than 5A.
- The output load line and input line shall be separated to improve noise sensitivity.
- Do not apply stress to PCB, when connecting or removing connector.
- Do not apply stress to other components, when connecting or removing connector.
- Use input/output connector (housing) specified by the table below.
- Use recommended crimping tool. Connector is not included with this product. (Refer to the following)

3. Block Diagram

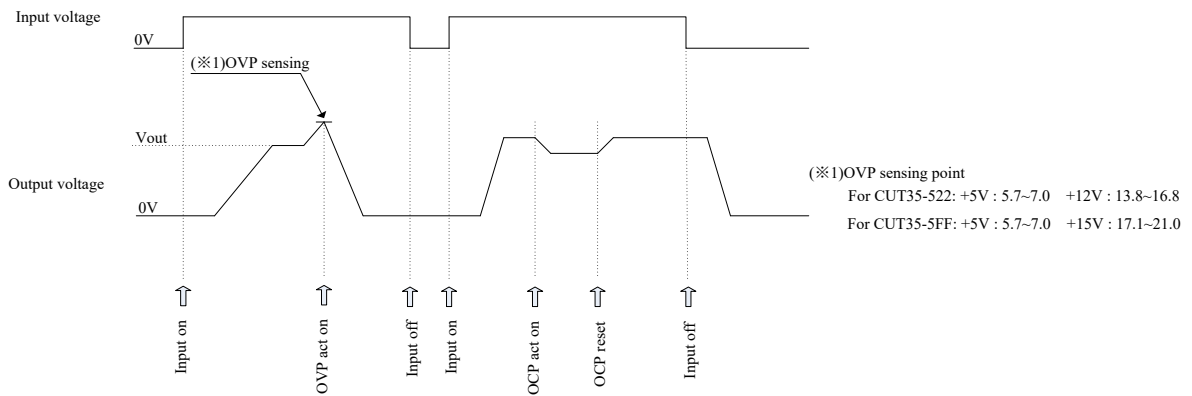
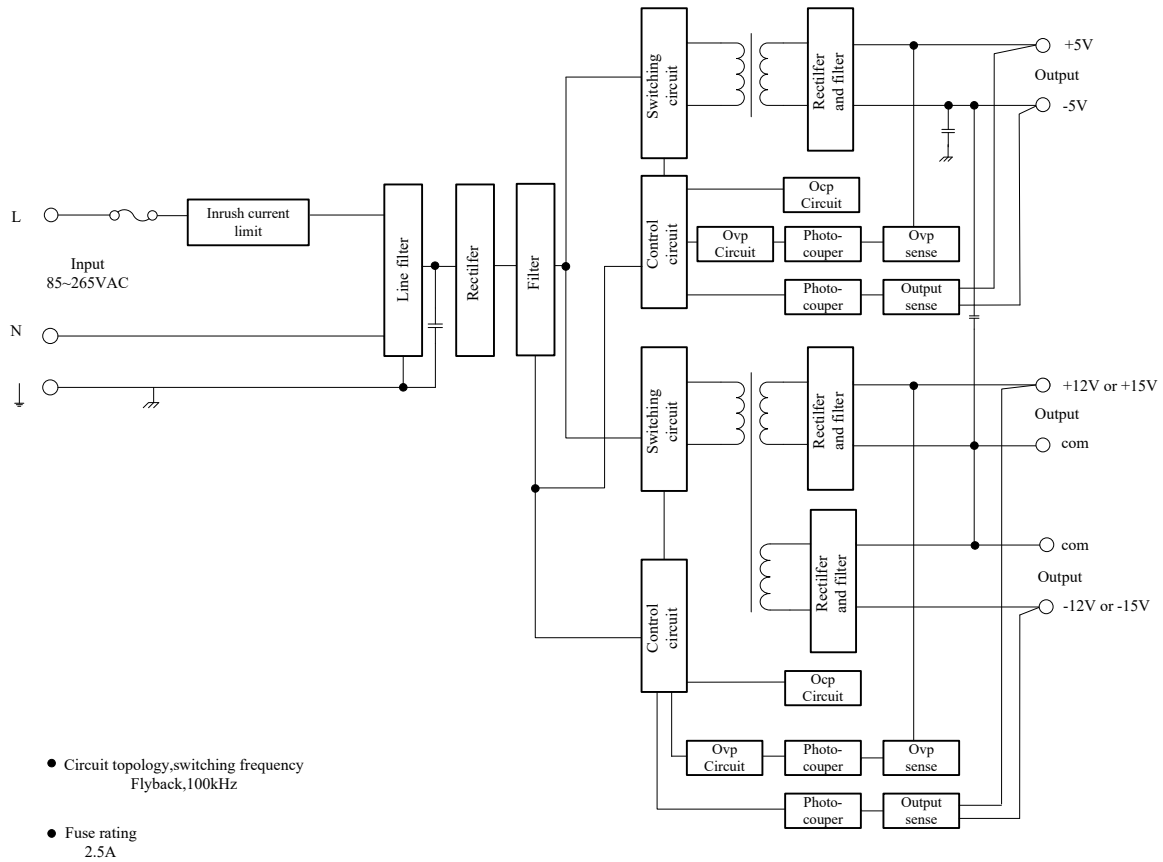

5. Terminal Connection Method

Pay attention to the input wiring. If it is connected to wrong terminal, the power supply will be damaged.

- Input must be off when making connections.
- terminal must be connected to protective earth of the equipment.
- Output current of each terminal pin must be less than 5A.
- The output load line and input line shall be separated to improve noise sensitivity.
- Do not apply stress to PCB, when connecting or removing connector.
- Do not apply stress to other components, when connecting or removing connector.
- Use input/output connector (housing) specified by the table below.
- Use recommended crimping tool. Connector is not included with this product. (Refer to the following)

Input/Output Connector

	Model	Connector	Housing	Terminal Pin	Maker
Input (CN1)	Common	B3P5-VH(LF)(SN)	VHR-5N	SVH-21T-P1.1 BVH-41T-P1.1	J.S.T.
Output (CN51)	Common	B5P-VH(LF)(SN)	VHR-5N		

Hand Crimping Tool : YC-930R, YC-931R (J.S.T.)

6. Explanation of Function and Precautions

6-1. Input Voltage Range

Input voltage range is single phase 85-265VAC(47-63Hz) or 88-370VDC. Never operate the unit out of the specified input voltage range to avoid unit failure. For cases where conformance to various safeties required, input voltage range will be 100-240VAC (50-60Hz). If input voltage is less than 105VAC, output power need to be derated, when ambient temperature is less than -10°C.

Derating curve of the Input voltage, when ambient temperature is less than -10°C.

Input Voltage	Load (%)
	All Mounting(A,B,C,D,E,F)
85VAC/88VDC	60
105~265VAC/105~370VDC	100

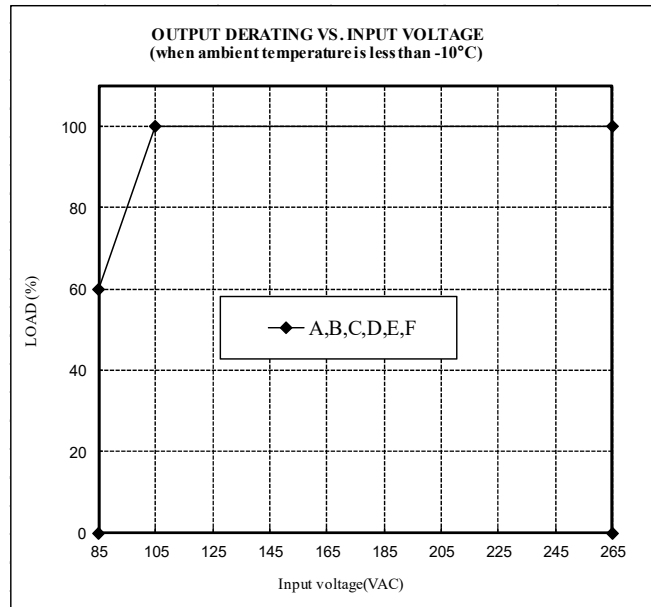

6-2. Output Voltage Range

Output voltage is set the rated value at shipment. V.ADJ trimmer (VR51) can adjust 5V output voltage within the range. Output voltage range refers to the specification. To turn the trimmer clockwise, the output voltage will be increased. Take note when the output voltage is increased excessively, over voltage protection (OVP) function may be triggered and voltage will be shut down. Furthermore, when increasing the output voltage reduce the output current so as not to exceed the maximum output power.

6-3. Inrush Current

These products equipped power thermistor to limit the inrush current. Higher inrush current will flow at higher ambient temperature or re-input condition. Please select input switch and fuse carefully with the high temperature and re-input the power condition. The Inrush Current value is under cold start at 25°C in the specification.

6-4. Over Voltage Protection (OVP)

The OVP function (Inverter shut down method, manual reset type) is provided for +5V and +12V(+15V). Please refer to its specification for OVP operating range. When OVP triggers, the output will be shut down. To reset OVP, remove the input of power supply for a few minutes, and then re-input. In addition, the setting value of OVP is fixed and not adjustable. Pay attention not to apply higher voltage externally to the output terminal to avoid unit failure. In case of inductive load, put protective diode in series to the output power line.

6-5. Over Current Protection (OCP)

The OCP is hiccup mode with automatic recovery. The outputs will be automatically recovered when the overload condition is canceled. OCP function operates when the output current exceeds 105% of maximum DC output current of specification. Never operate the unit under over current or shorted conditions for more than 30seconds, which may leads damage or insulation failure. OCP setting is fixed and not to be adjusted externally.

6-6. Output Ripple & Noise

The standard specification for maximum ripple value is measured according to measurement circuit specified as below. When load lines are longer, ripple will becomes larger. In this case, electrolytic capacitor, film capacitor, etc. might be necessary to use across the load terminal. The output ripple cannot be measured accurately if the probe ground lead of oscilloscope is too long. A circuit reducing light load input power consumption is built in this model. When output current is within 0-35% of rated load, the internal switch element is intermittent operated, and the switching loss is decreased. The specification of the Ripple & Noise changes by this intermittent operation. The dynamic load response characteristic changes by this intermittent operation too. Different input voltage and dynamic load condition has different dynamic load response characteristic. Please contact us for details.

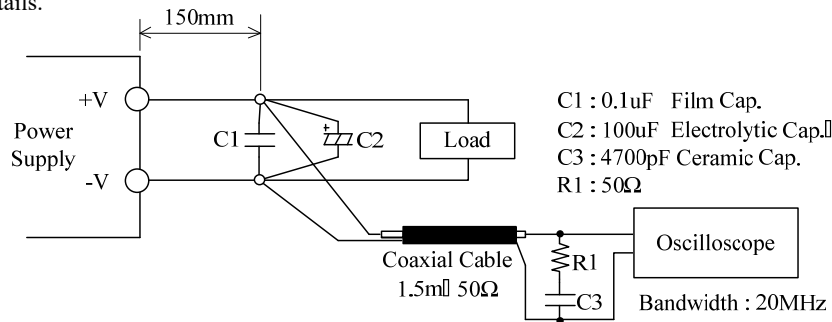

6-7. Isolation Test

Isolation resistance between Output and \perp (Protective Earth) is more than 100MΩ at 500VDC. For safety operation, voltage setting of DC isolation tester must be done before the test. Ensure that the unit is fully discharged after the test

Output - \perp (Protective Earth) : 500VDC More than 100MΩ

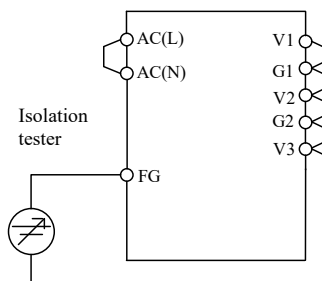

6-10. Withstand Voltage

These series are designed to withstand 3.0kVAC(10mA) between input and output, 2.0kVAC(10mA) between input and \perp (Protective Earth), and 500VAC(20mA) between output and \perp (Protective Earth), 500VAC(20mA) between each CH1 and CH2/CH3, each for 1 minute. When testing withstand voltage, set current limit of the withstand voltage test equipment to 10mA/20mA. The applied voltage must be gradually increased from zero to the testing value and then gradually decreased for shut down. When timer is used, the power supply may be damaged by high impulse voltage at timer switch on and off. Connect input and output as follows.

Input - Output(Dashed line) : 3.0kVAC 1min(10mA)
 Input - \perp (Protective Earth)(Solid line) : 2.0kVAC 1min(10mA)

Output - \perp (Protective Earth) : 500VAC 1min(20mA)
 CH1-CH2/CH3: 500VAC 1min(20mA)

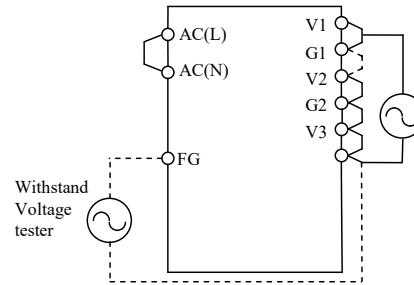
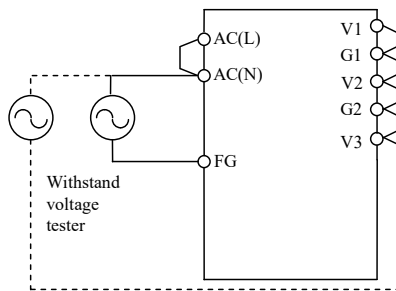

Instructions for using the power supply in customer's system

1. If the output of power supply is connected to FG in the application, the withstand voltage test between input and output (FG) should be tested at 2kVAC.
2. If there is external noise filter and Y-caps connected at the input and output of the power supply, the voltage distribution between primary and secondary circuit will be changed during the withstand voltage test, and may cause test fail. In this case, please contact TDK-Lambda for the technical support and instructions.

7. Mounting Directions

7-1. Mounting Directions.

Recommended standard mounting direction is (B). (A) (C) (D) (E) (F) are also possible.

(A) (B) Standard mounting (C) (D) (E) (F)

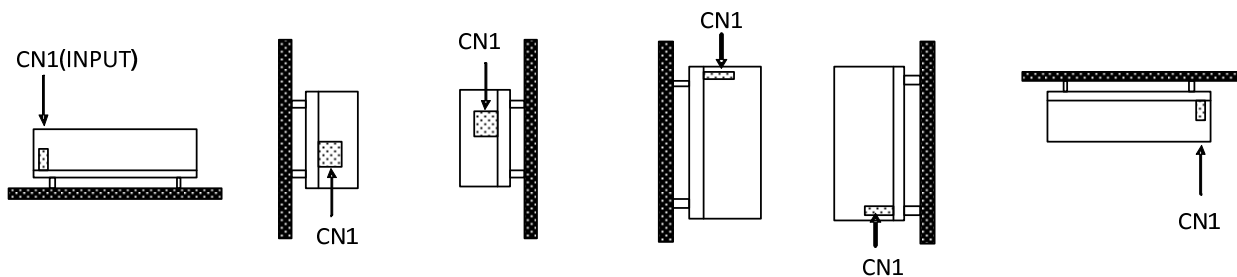

7-2. Output Derating

7-2-1. Output derating for Standard model

Make sure that the specified temperature range is maintained.

Convection Cooling

Ta (°C)	LOADING CONDITION(%)		
	Mounting A,C,E	Mounting B	Mounting D,F
-20	100	100	100
45	100	100	100
50	100	100	90
55	90	100	80
60	80	90	70
65	70	80	60
70	60	70	50

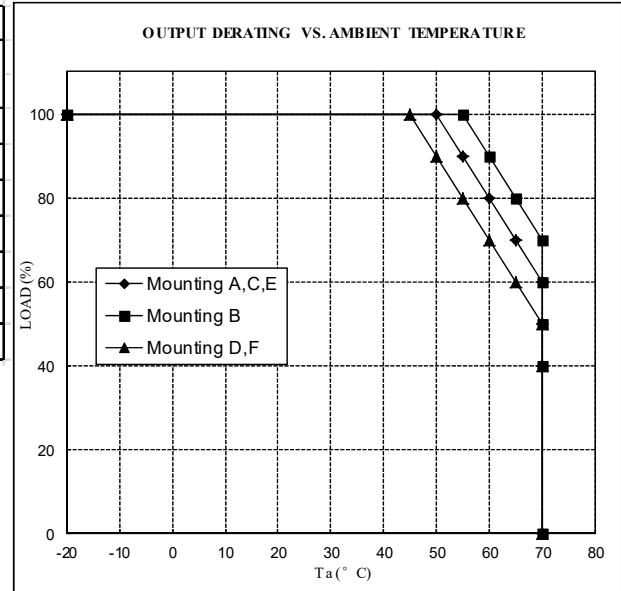

Forced air Cooling

Ta (°C)	LOADING CONDITION(%)
	Mounting A,B,C,D,E,F
-20-60	100
70	70

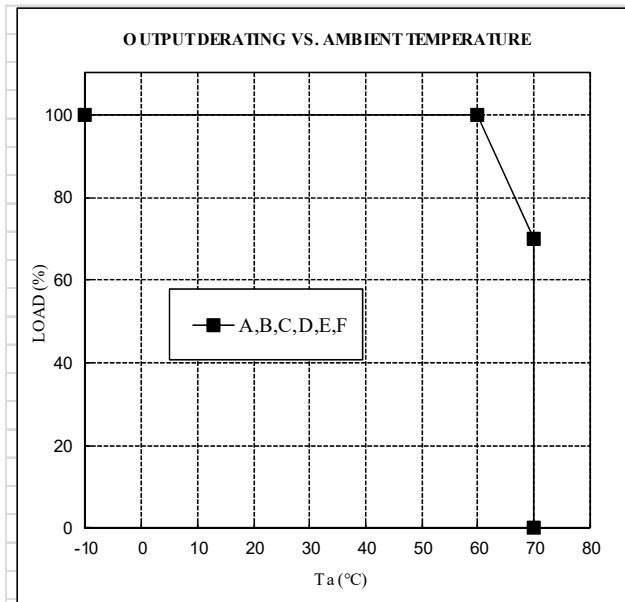

*Recommended minimum air velocity : 0.7m/s. (Measured at component side of PCB, air must flow through component side)As a reference for forced air cooling, let air flow so that the C51,C61,C62 temperature is lower than 75°C.

7-2. Output Derating

7-2-2. Output derating for for /L and /A model

Make sure that the specified temperature range is maintained.

Convection Cooling

Ta (°C)	LOADING CONDITION(%)		
	Mounting A,C,E	Mounting B	Mounting D,F
-20C	100%	100%	100%
35C	100%	100%	100%
40C	100%	100%	90%
45C	90%	100%	80%
50C	80%	90%	70%
55C	70%	80%	60%
60C	60%	70%	50%

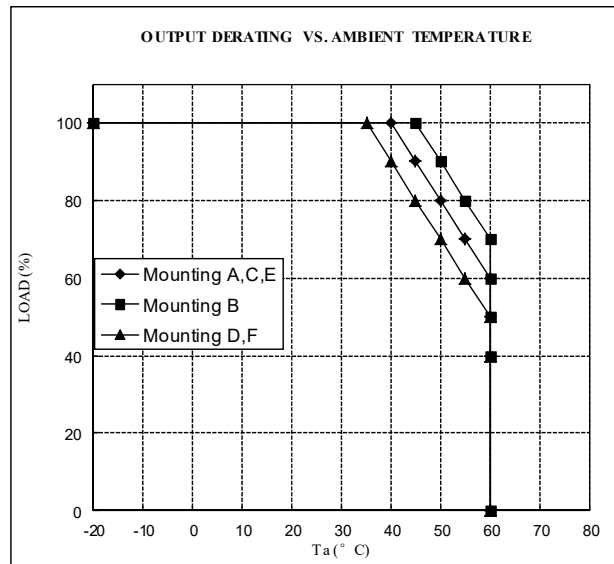

Forced air Cooling

Ta (°C)	LOADING CONDITION(%)
	Mounting A,B,C,D,E,F
-20-50	100
60	70

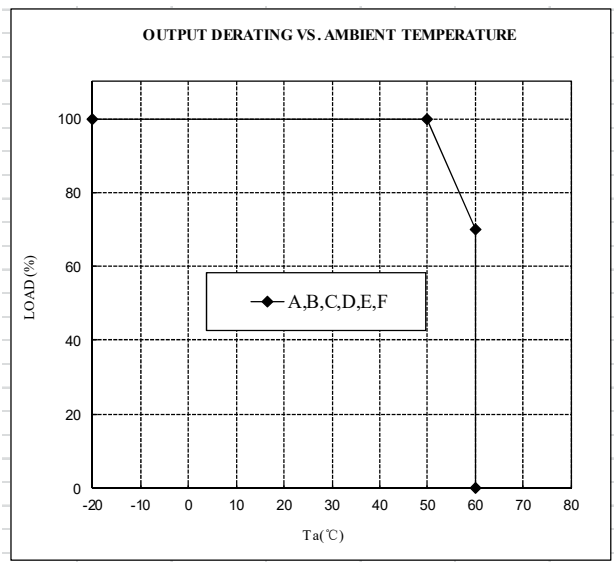

*Recommended minimum air velocity : 0.7m/s. (Measured at component side of PCB, air must flow through component side)As a reference for forced air cooling, let air flow so that the C51,C61,C62 temperature is lower than 75°C.

7-3. Mounting Method

7-3-1. Mounting method for standard model

All four mounting holes on this model should be utilized for best electrical and mechanical performance, with 10mm (minimum height) metal standoffs.

▪ **Mounting Holes size**

4 holes $\phi 3.5\text{mm}$.

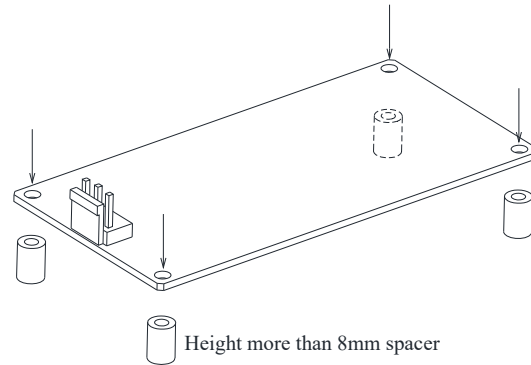

Refer to the shadow in the figure below for allowable area touched by conductive material on top and bottom side of the PCB.

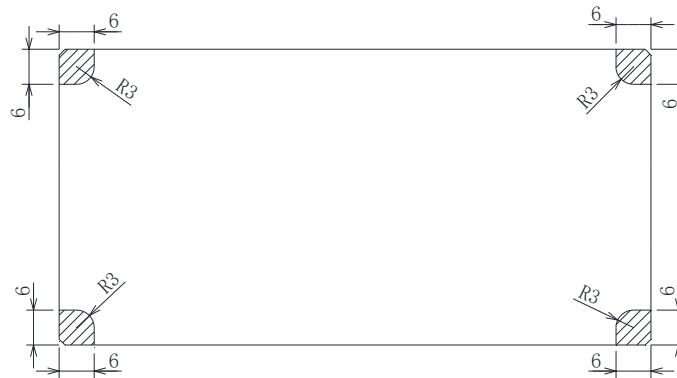

▪ **Condition to meet Isolation, Withstand Voltage and Cooling requirement.**

Keep 4mm space minimum from the surface and sides of power supply, 8mm space minimum from the bottom side of PCB to meet safety requirement, or more space depend on safety requirement. If the space is not enough, the specification of isolation and withstand voltage will not be satisfied.

More space may be required in the surrounding of power supply and the upper area of components for effective cooling depends on the application conditions.

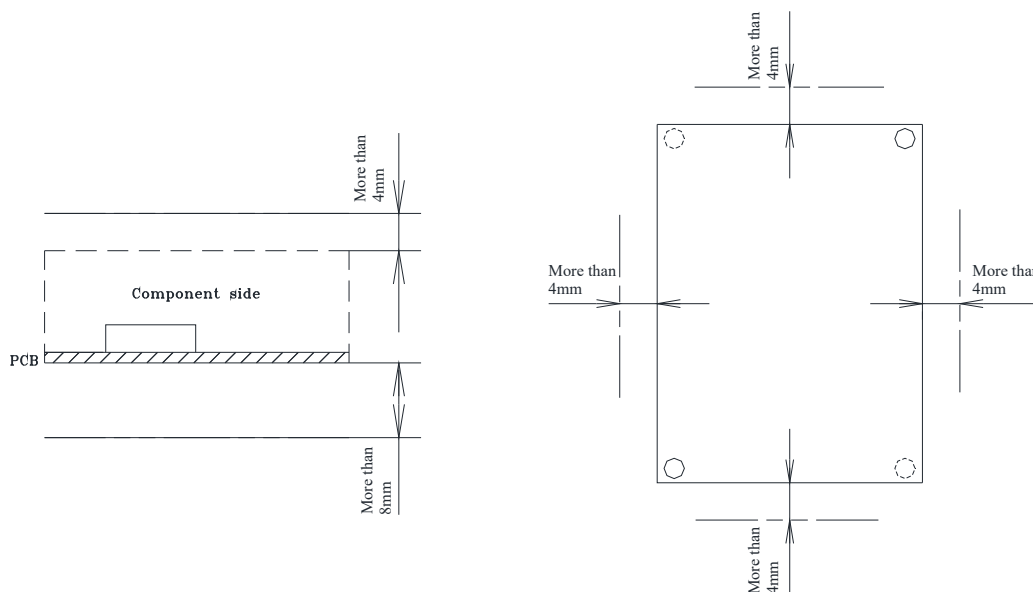

⏏ terminal (Protective Earth) must be connected to the earth terminal of the equipment, also the two mounting holes (as shown below) needed to be connected to earthed metal plane or metal chassis of end product by metal spacer to ensure EMC and EMI performance.

All equipment ideally should be mounted inside an earthed shielded metal box. Alternatively an earthed metal plate can be used to mount the power supply and load.

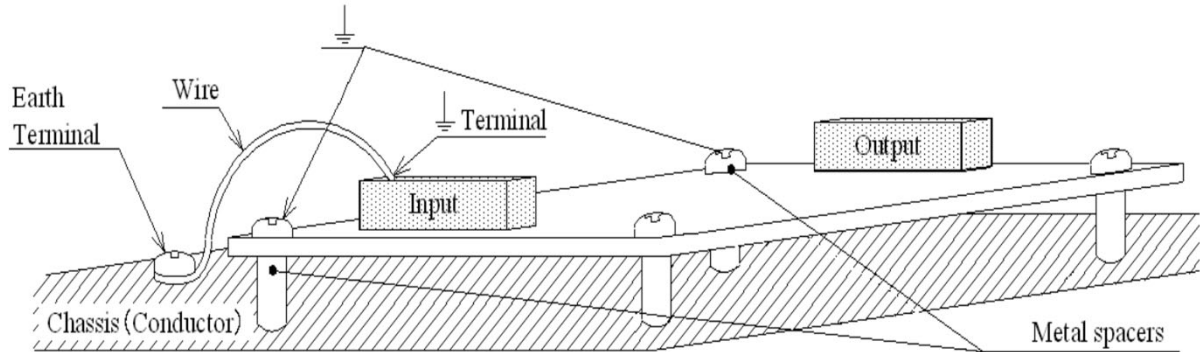

7-3-3. Mounting method for /A model

/A model is optional model with metal chassis and cover.

The mounting holes on the bottom of the chassis are for power supply fixing. The M3 tapped and standoff hole near the input connector can be used to connect to the protective earth.

Refer to the /A model outline drawings for the detailed dimensions.

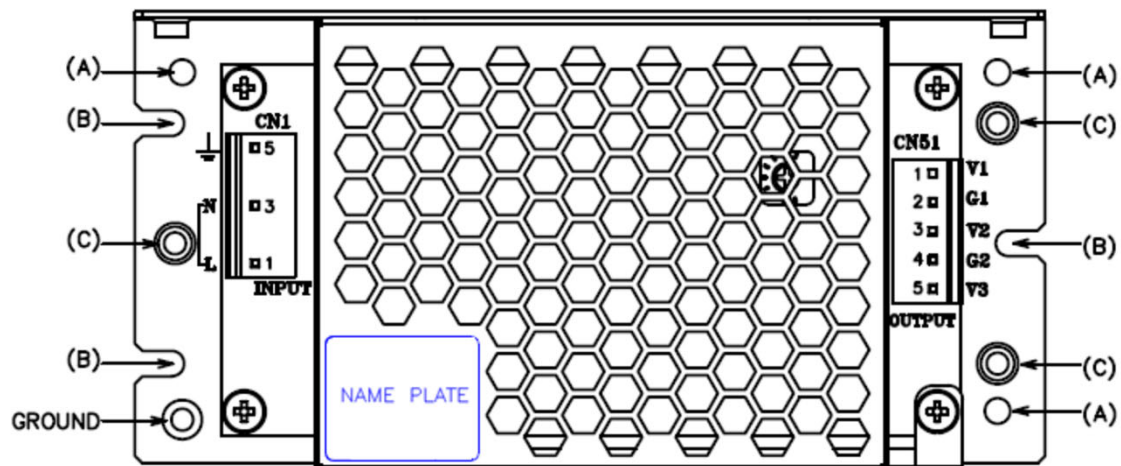

▪ Mounting Holes

A: 3- ϕ 3.5 holes for customer chassis mounting.

B: 3- ϕ 3.5 holes for customer chassis mounting.

C: 3-M3 tapped, embossed and countersink holes for mounting screws to fix the power supply from bottom.

Ground: M3 stud for protective earth

8. Wiring Method

This power supply is primarily designed and manufactured to be used and enclosed in other equipment. The installation, wiring, grounding and end application of the switching power supply in the equipment system may influence its EMC characteristics. Therefore, the EMC performance has to be tested on end system level. Additional filtering may be required depends on application and installation methods.

Please refer to following application notes which may help to improve EMC performance.

- (1) The output load line and input line shall be separated each other and twisted individually to improve noise.
- (2) Use all lines as thick and short as possible to made lower impedance.
- (3) Noise can be reduced by attaching a capacitor to the load terminals.
- (4) For safety and EMI considerations, connect \perp (Protective Earth) terminal and Frame Ground terminal of equipment firmly.

9. The life expectancy

The life of the power supply depends on the life of the built-in aluminum electrolytic capacitor. The life is described in reliability data.

The life of the aluminum electrolytic capacitor varies depending on the method of mounting the power supply, the load current, and the ambient temperature. Please refer to "Electrolytic Capacitor Lifetime".

Please do not use the product which passed over the life expectancy. There is a risk of unexpected output shutdown and specifications may not be satisfied.

Please contact us for maintenance or exchange the product which passed over the life expectancy.

10. External Fuse Rating

Refer to the following fuse rating when selecting the external fuses that are to be used on input line. Surge current flows when line turns on. Have to use slow-blow or time-lag type fuse, not fast-blow fuse. Fuse rating is considered by in-rush current value at line turn-on. Do not select the fuse according to input current (RMS.) values under the actual load condition

CUT35: 2.5A

11. Before concluding that the unit is at fault

- (1) Check if the rated input voltage is connected.
- (2) Check if the wiring of input and output is correct.
- (3) Check if the wire thickness is enough.
- (4) Check if the output current and output power does not over specification.
- (5) Check if the output voltage adjust trimmer (V.ADJ) is properly adjusted. OVP might be triggered and output is shut down.
- (6) Audible noise can be heard when input voltage waveform is not sinusoidal wave.
- (7) Audible noise can be heard during Dynamic-Load operation.
- (8) Ensure that a large capacitor is not connected across the output terminals. Please use within maximum capacitance shown below.

Maximum external capacitance					
CUT35-522			CUT35-5FF		
5V	+12V	-12V	5V	+15V	-15V
8800uF	1200uF	1200uF	8800uF	800uF	800uF

12. Altitude

CUT35 is safety approved for operation at below altitude.

- Up to 3000m by IEC60950-1 clearance requirement.

- Up to 3000m by IEC60601-1 clearance requirement.

Thermal evaluation should be considered for products operating at elevated altitudes above 2000m.

13. Warranty Condition

This product is warranted for a period of 3 years from the date of shipment.
For damages occurring at normal operation within this warranty period, repair is free of charge.
Please read the General Safety Instruction before using the products.

14. CE Marking/UKCA Marking

CE Marking

CE Marking, when applied to a product or packing material for a product covered by this handbook, indicates compliance with Low Voltage Directive, EMC Directive and RoHS Directive.

UKCA Marking

UKCA Marking, when applied to a product or packing material for a product covered by this handbook, indicates compliance with the Electrical Equipment (Safety) Regulations, Electromagnetic Compatibility Regulations and Restriction of the Use of Certain Hazardous Substances in Electrical & Electronic Equipment Regulations.