

PFE700S

SPECIFICATIONS

C253-01-01B

ITEMS		MODEL	PFE700S
1	Nominal Output Voltage (*1)	-	51V
2	Output Voltage Regulation Range (*7)	-	50V - 57V
3	Output Voltage Accuracy (*1)	-	+/-1V
4	Maximum Output Current	-	14A
5	Nominal Output Power	-	714W
6	Efficiency (Typ.) (*1)	-	86 / 89%
7	Input Voltage Range (*2) (*5)	-	85 - 265 VAC
8	Input Frequency (*2)	-	47 - 63Hz
9	Input Current (*1)	-	8.8 / 4.4A
10	Power Factor (*1)(*5)	-	0.95 min
11	Maximum Ripple & Noise (*5)	-	4V
12	Over Current Protection	-	105% - 140% (Automatic recovery method)
13	Over Voltage Protection	-	60.0V - 69.6V (Inverter shutdown method)
14	In-rush Current (Typ.) (*1)(*5)	-	20A / 40A peak
15	Parallel Operation (*6)	-	Possible
16	Series Operation (*6)	-	Possible
17	Operating Temperature (*3)	-	-40°C - +100°C(Baseplate) Ambient Temperature min=-40°C
18	Operating Humidity	-	20 - 95%RH (No Dewdrop)
19	Storage Temperature	-	-40°C - +100°C
20	Storage Humidity	-	10 - 95%RH (No Dewdrop)
21	Cooling (*4)	-	Conduction Cooled
22	Withstand Voltage	-	Input-Baseplate : 2.5kVAC, Input-Output : 3.0kVAC for 1min. Output-Baseplate : 1.5kVDC for 1min.
23	Isolation Resistance	-	Output to Baseplate 500VDC more than 100MΩ (25°C,70%RH)
24	Vibration	-	At No Operating, 10-55Hz (Sweep for 1min.) Amplitude 0.825mm Constant (Maximum 49.0m/s ²) X,Y,Z 1 hour each
25	Shock	-	196.1m/s ²
26	Safety	-	Approved by UL60950-1,CSA60950-1,EN60950-1
27	Weight (Typ.)	-	250g
28	Size (W x H x D)	mm	61 x 12.7 x 116.8 (Refer to Outline Drawing)

*Read instruction manual carefully, before using the power supply unit.

=NOTES=

- *1. At 100VAC/200VAC and maximum output power.
(Baseplate Temperature = +25°C.)
- *2. For cases where conformance to various safety specs
(UL, CSA, EN) are required, input voltage range
will be 100 - 240VAC(50/60Hz).
- *3. Ratings - refer to Derating Curve on the right.
- *4. Heatsink has to be chosen according to Instruction manual.
- *5. External components are needed for operation.
(Refer to basic connection and instruction manual.)
- *6. Refer to Instruction manual.
- *7. For all input voltage, output load and temperature range.

Derating Curve

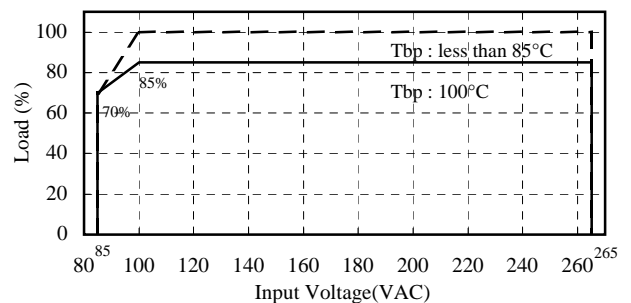
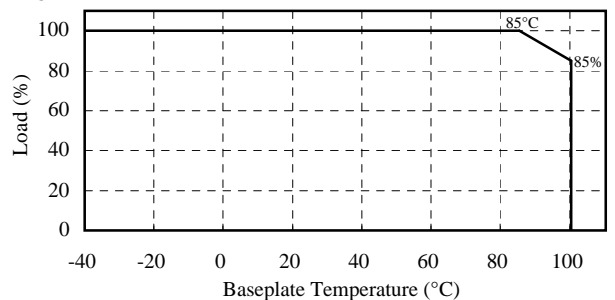

PFE700S

C253-01-02C

BASIC CONNECTION

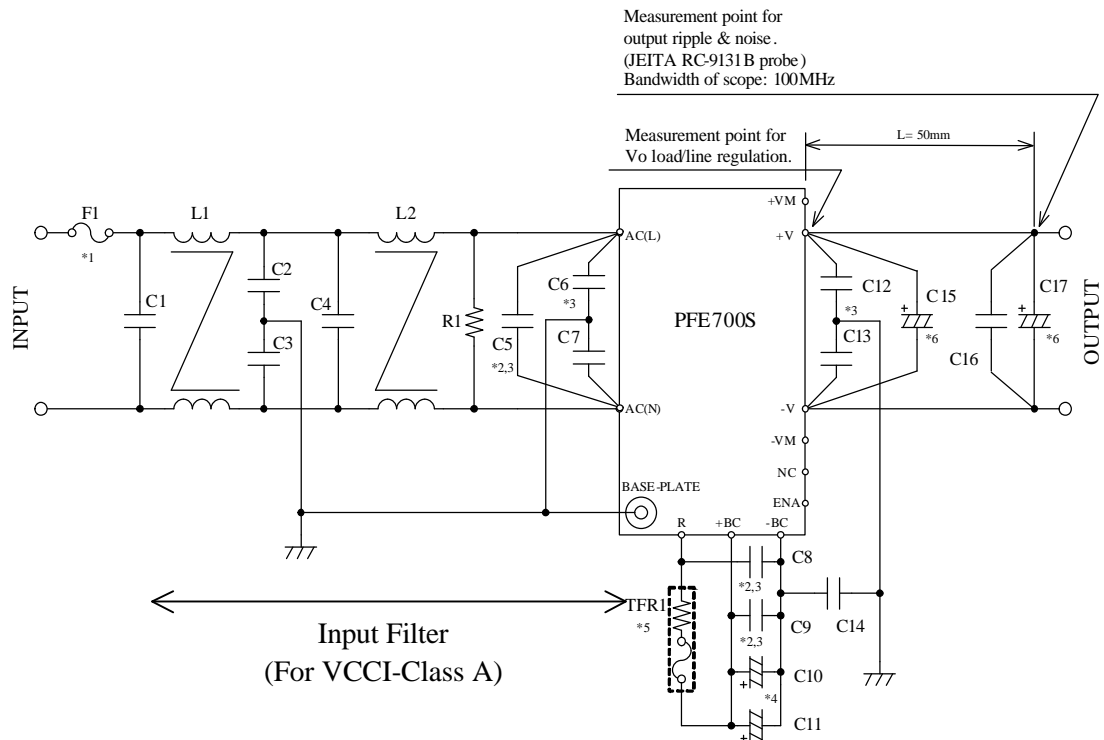

F1	AC250V 15A	C11	450V 390uF
C1	AC250V 1uF (Film)	C12	0.033uF
C2	4700pF	C13	0.033uF
C3	4700pF	C14	1000pF
C4	AC250V 1uF (Film)	C15	100V 220uF (Elec.)
C5	AC250V 1uF (Film)	C16	100V 2.2uF (Ceramic)
C6	1000pF	C17	100V 220uF (Elec.)
C7	1000pF	R1	0.5W 470kΩ
C8	450V 1uF (Film)	TFR1	10Ω 139°C (Res., Thermal fuse)
C9	450V 1uF (Film)	L1	6mH
C10	450V 390uF	L2	6mH

==NOTES==

- *1. Use an external fuse of fast blow type for each unit.
- *2. The allowable ripple current of capacitor must be more than 3A(rms).
- *3. Put this capacitor near the terminal as close as possible.
- *4. The maximum capacitance that can be used is less than 1200uF(Rated capacitance).
Avoid the connection of capacitance which is more than above, else it will lead to module to damage.
- *5. The inrush current at AC throw in can be suppressed by the external Resistor (Built-in thermal fuse) connected between the R and +BC terminals.
- *6. If the ambient temperature is less than -20°C, use twice the recommended capacitor above.
- *7. Do not make external connection.
- *8. Refer to instruction manual for further details.