

SR660 Specifications

NEMIC-LAMBDA

* : For delivery, contact to our sales office.

A088-01-01B

| ITEMS | | MODEL | SR660 | SR660 | SR660 | SR660 | SR660 | SR660 | SR660 | SR660 | SR660 | SR660 | SR660 |
|-------|------------------------------|---------|---|---------------------------------|------------------|----------------|----------------|----------------|----------------|----------------|----------------|----------------|----------------|
| | | | -2 | -5 | -6 | -9 | -12 | -15 | -18 | -20 | -24 | -28 | -48 |
| 1 | Nominal Output Voltage | V | 2 | 5 | 6 | 9 | 12 | 15 | 18 | 20 | 24 | 28 | 48 |
| 2 | Maximum Output Current (*9) | A | 132 | 132 | 110 | 74 | 56 | 45 | 37.5 | 33 | 28 | 24 | 14 |
| 3 | Maximum Output Power | W | 264 | 660 | 660 | 666 | 672 | 675 | 675 | 660 | 672 | 672 | 672 |
| 4 | Efficiency (Typ) (*1) | % | 63 | 76 | 76 | 79 | 82 | 82 | 82 | 82 | 84 | 84 | 84 |
| 5 | Input Voltage Range (*2) | - | 85 ~ 132VAC / 170 ~ 265VAC(47 ~ 440Hz) selectable or 230 ~ 330VDC Input Voltage Range shown on Front Panel : 100 - 120 / 200 - 240VAC (50 / 60Hz). | | | | | | | | | | |
| 6 | Input Current (Typ) (*1) | A | 100V:8.0A 200V:4.0A | 100VAC : 16.0A 200VAC : 8.0A | | | | | | | | | |
| 7 | Inrush Current(Typ) (*3) | - | 30A at 100VAC, 60A at 200VAC (260VDC) | | | | | | | | | | |
| 8 | Output Voltage Range (Typ) | % | -10~+20 | | -20~+10 | | ±20% | | | | | | |
| 9 | Maximum Ripple & Noise | mV | 100 | | 200 | | | | | | | 400 | |
| 10 | Maximum Line Regulation (*4) | mV | 20 | 20 | 24 | 36 | 48 | 60 | 72 | 80 | 96 | 112 | 192 |
| 11 | Maximum Load Regulation (*5) | mV | 20 | 20 | 24 | 36 | 48 | 60 | 72 | 80 | 96 | 112 | 192 |
| 12 | Over Current Protection (*6) | A | 145.0 ~ 171.0 | 145.0 ~ 171.0 | 121.0 ~ 143.0 | 81.0 ~ 96.0 | 61.6 ~ 72.8 | 49.5 ~ 58.5 | 41.2 ~ 48.8 | 42.0 ~ 48.0 | 30.8 ~ 36.6 | 26.6 ~ 31.2 | 15.4 ~ 18.2 |
| 13 | Over Voltage Protection (*7) | V | 2.8 ~ 3.2 | 6.0 ~ 7.0 | 7.8 ~ 9.0 | 11.7 ~ 13.5 | 15.6 ~ 18.0 | 19.5 ~ 22.5 | 23.4 ~ 27.0 | 26.0 ~ 30.0 | 31.2 ~ 36.0 | 36.4 ~ 42.0 | 62.4 ~ 72.0 |
| 14 | Hold-up Time (Typ) (*8) | ms | 20ms | | | | | | | | | | |
| 15 | Remote Sensing | - | Possible | | | | | | | | | | |
| 16 | Remote ON/OFF Control | - | Possible | | | | | | | | | | |
| 17 | Parallel Operation | - | Possible | | | | | | | | | | |
| 18 | Series Operation | - | Possible | | | | | | | | | | |
| 19 | Operating Temperature (*9) | - | -20 ~ +71°C | | | | | | | | | | |
| 20 | Operating Humidity | - | 30 ~ 95%RH (No dewdrop) | | | | | | | | | | |
| 21 | Storage Temperature | - | -40 ~ +85°C | | | | | | | | | | |
| 22 | Storage Humidity | - | 10 ~ 95%RH (No dewdrop) | | | | | | | | | | |
| 23 | Cooling | - | Forced air by blower fan (Blower fan is mounted within supply) | | | | | | | | | | |
| 24 | Temperature Coefficient | - | Less than 0.03% / °C | | | | | | | | | | |
| 25 | Withstand Voltage (*10) | - | Input - Chassis : 2.5kVAC 1 min, Input - Output : 3.75kVAC 1 min, Output - Chassis : 500VAC 1 min. | | | | | | | | | | |
| 26 | Isolation Resistance | - | More than 100MΩ at 25°C and 70%RH Output - Chassis : 500VDC | | | | | | | | | | |
| 27 | Vibration | - | At no operating, 10 ~ 55Hz Amplitude (sweep for 1min) 0.825mm constant (Maxmum 5G) X, Y, Z 1hour each | | | | | | | | | | |
| 28 | Shock | - | Less than 20G | | | | | | | | | | |
| 29 | Safety Standard | UL1950 | Approved by UL | | | | | | | | | | |
| | | CSA950 | Approved by C-UL | | | | | | | | | | |
| | | EN60950 | Approved by TUV (Approved model:SR660-5,SR660-12,SR660-24) | | | | | | | | | | |
| 30 | Conducted Emission | - | Built to meet VCCI-Class A, FCC-Class A, VDE-Class A | | | | | | | | | | |
| 31 | Weight | kg | 4.0 | | | | | | | | | | |
| 32 | Size (WxHxD) | mm | 189 x 96.5 x 215 (Refer to Outline Drawing) | | | | | | | | | | |
| 33 | Monitoring Signal | - | FAN ALM, PF (Open Collector output) | | | | | | | | | | |

*Read instruction manual carefully, before using the power supply unit.

=NOTES=

- *1. At 100V/200VAC and maximum output power.
- *2. For cases where conformance to various safety specs (UL, CSA, etc) are required, input voltage range will be 100 - 120 / 200 - 240VAC (50 / 60Hz).
- *3. First in-rush current .
- *4. From 85 ~ 132VAC or 170 ~ 265VAC, constant load.
- *5. From No load ~ Full load, constant input voltage.
- *6. Constant current limiting with automatic recovery. (The unit automatically shuts down the output when it is left for 30 seconds under the state that OCP is operating and the output voltage is less than PF detected level. The output recovers when the input voltage is turned on after brief turning off.)
- *7. Inverter shut-down method, manual reset. (OVP circuit will shut-down output)
- *8. At 100V/200VAC, nominal output voltage & maximum output current.
- *9. Ratings - For 5V model, refer to derating curve on the right.

For other Voltage models, refer to attached Derating Table.

- Load (%) is percent of maximum output power or maximum output current, whichever is greater.

- *10. Leacage current range used : Input -Chassis greater than 20mA
Input -Output greater than 20mA (ACG - FG open)
Output -Chassis greater than 100mA

DERATING CURVE (5V TYPE)
MOUNTING A

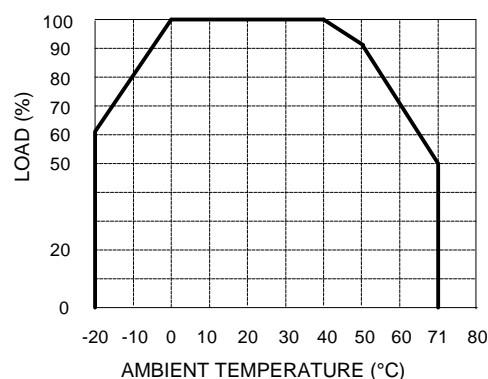

SR 660 OUTPUT DERATING

NEMIC-LAMBDA

MOUNTING (A), (B), (C)

| MODEL | Ta (°C) | Nominal Output Voltage | MAXIMUM OUTPUT CURRENT OR MAXIMUM OUTPUT POWER, WHICHEVER IS GREATER | | | | |
|----------|---------|------------------------|--|----------|------|------|------|
| | | | -20°C | 0 ~ 40°C | 50°C | 60°C | 71°C |
| SR660-2 | 2V | 2V | 80A | 132A | 120A | 90A | 66A |
| | | | 160W | 264W | 240W | 180W | 132W |
| SR660-5 | 5V | 5V | 80A | 132A | 120A | 90A | 66A |
| | | | 400W | 660W | 600W | 450W | 330W |
| SR660-6 | 6V | 6V | 66A | 110A | 100A | 77A | 55A |
| | | | 396W | 660W | 600W | 462W | 330W |
| SR660-9 | 9V | 9V | 44A | 74A | 68A | 52A | 37A |
| | | | 396W | 666W | 612W | 468W | 333W |
| SR660-12 | 12V | 12V | 34A | 56A | 53A | 40A | 28A |
| | | | 408W | 672W | 636W | 480W | 336W |
| SR660-15 | 15V | 15V | 27A | 45A | 43A | 32A | 23A |
| | | | 405W | 675W | 645W | 480W | 345W |
| SR660-18 | 18V | 18V | 23A | 37.5A | 35A | 27A | 20A |
| | | | 414W | 675W | 630W | 486W | 360W |
| SR660-20 | 20V | 20V | 20A | 33A | 31A | 23A | 17A |
| | | | 400W | 660W | 620W | 460W | 340W |
| SR660-24 | 24V | 24V | 17A | 28A | 27A | 20A | 14A |
| | | | 408W | 672W | 648W | 480W | 336W |
| SR660-28 | 28V | 28V | 15A | 24A | 23A | 17A | 12A |
| | | | 420W | 672W | 644W | 476W | 336W |
| SR660-48 | 48V | 48V | 8.5A | 14A | 13A | 10A | 7A |
| | | | 408W | 672W | 624W | 480W | 336W |

OUTPUT DERATING CURVE
MOUNTING : A, B, C (5V)

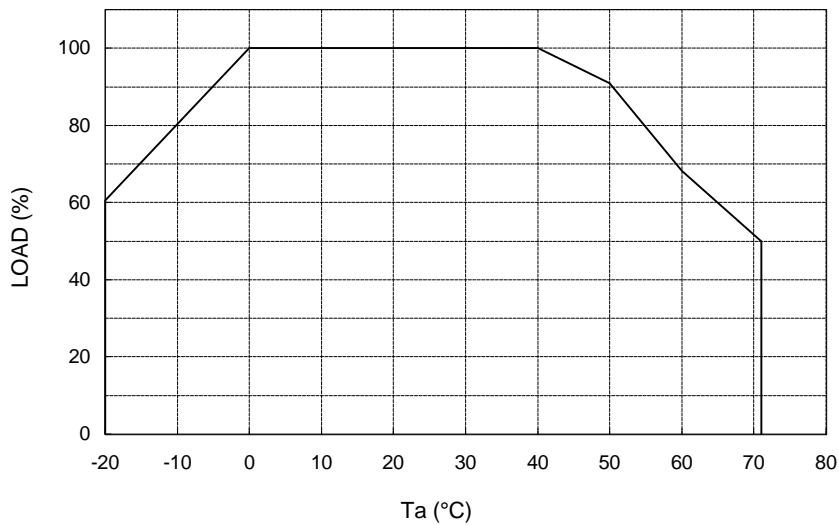

MOUNTING : A
(STANDARD MOUNTING)

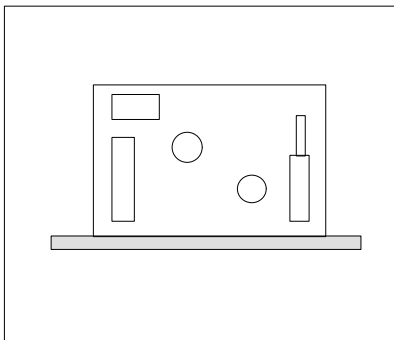

MOUNTING : B

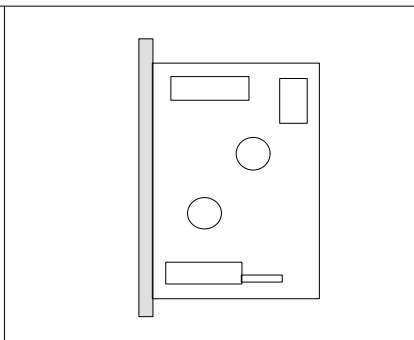

MOUNTING : C

