

# CCG3-24-xxS

## EVALUATION DATA

### 型式データ

## INDEX

	PAGE
<b>1. 測定方法 Evaluation Method</b>	
1-1. 測定回路 Measurement Circuits .....	3
(1) 静特性、待機電力特性、通電ドリフト特性、その他特性 Steady state, Standby power, Warm up voltage drift and Other characteristics	
(2) 入力サージ電流(突入電流)波形 Inrush current waveform	
(3) 出力リップルノイズ電圧、波形 Output ripple and noise voltage and waveform	
(4) EMI特性 Electro-Magnetic Interference characteristics	
1-2. 使用測定機器 List of equipment used .....	5
<b>2. 特性データ Characteristics</b>	
2-1. 静特性 Steady state characteristics	
(1) 入力・負荷・温度変動 Regulation - line and load, Temperature drift .....	6
(2) 出力電圧・出力リップルノイズ電圧 対 入力電圧 Output voltage and Output ripple and noise voltage vs. Input voltage .....	7
(3) 入力電流・効率 対 出力電流 Input current and Efficiency vs. Output current .....	9
(4) 効率 対 入力電圧 Efficiency vs. Input voltage .....	11
(5) 起動・遮断電圧特性 Start up and Drop out voltage characteristics .....	13
2-2. 待機電力特性 Standby power characteristics .....	15
2-3. 通電ドリフト特性 Warm up voltage drift characteristics .....	17
2-4. 過電流保護特性 Over current protection (OCP) characteristics .....	19
2-5. 出力立ち上がり・立ち下がり特性 Output rise and fall characteristics .....	21
2-6. 過渡応答(負荷急変)特性 Dynamic load response characteristics .....	29
2-7. 入力サージ電流(突入電流)特性 Inrush current characteristics .....	30
2-8. 出力リップルノイズ波形 Output ripple and noise waveform .....	31
2-9. EMI特性 Electro-Magnetic Interference characteristics .....	32

## 使用記号 Terminology used

	定義	Definition
$V_{in}$	..... 入力電圧	Input voltage
$V_o$	..... 出力電圧	Output voltage
$V_{RC}$	..... RC電圧	RC voltage
$I_{in}$	..... 入力電流	Input current
$I_o$	..... 出力電流	Output current
$T_a$	..... 周囲温度	Ambient temperature
$f$	..... 周波数	Frequency

※ 当社測定条件における結果であり、参考値としてお考え願います。  
Test results are reference data based on our measurement condition.

1. 測定方法 Evaluation Method

1-1. 測定回路 Measurement Circuits

(1) 静特性、待機電力特性、通電ドリフト特性、その他特性

Steady state, Standby power, Warm up voltage drift and Other characteristics

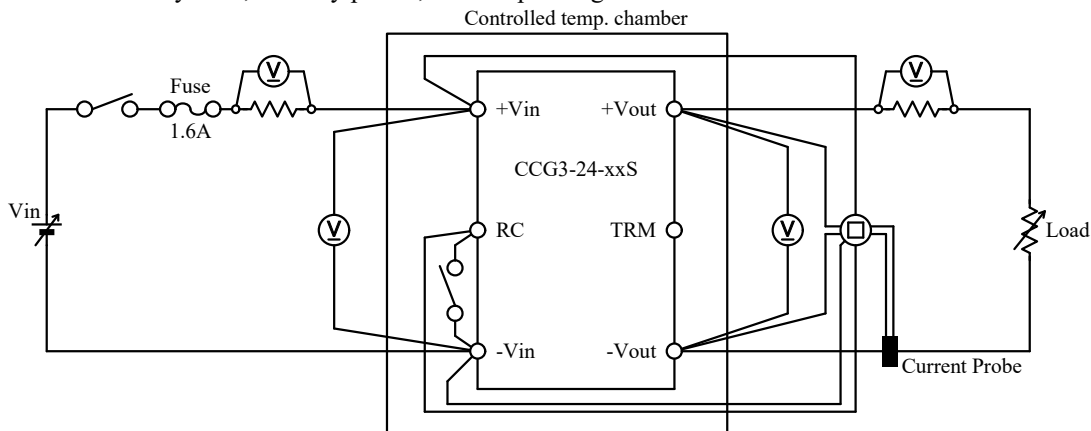

(2) 入力サージ電流(突入電流)波形 Inrush current waveform

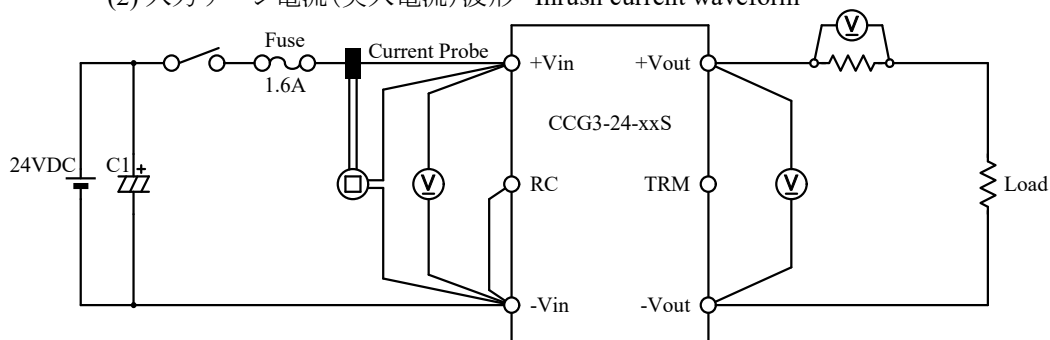

(3) 出力リップルノイズ電圧、波形 Output ripple and noise voltage and waveform

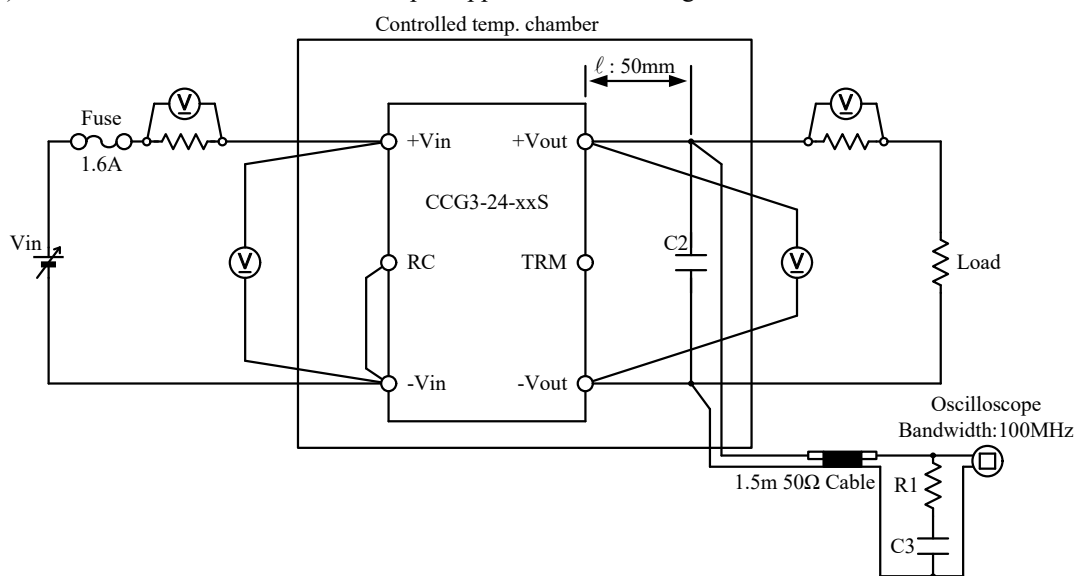

C1 : 4000 $\mu$ F  
 C2 : 1 $\mu$ F  
 C3 : 4700pF  
 R1 : 50 $\Omega$

Electrolytic Capacitor  
 Ceramic Capacitor  
 Ceramic Capacitor

(4) EMI特性 Electro-Magnetic Interference characteristics

(a) 雑音端子電圧(帰還ノイズ) Conducted Emission Noise

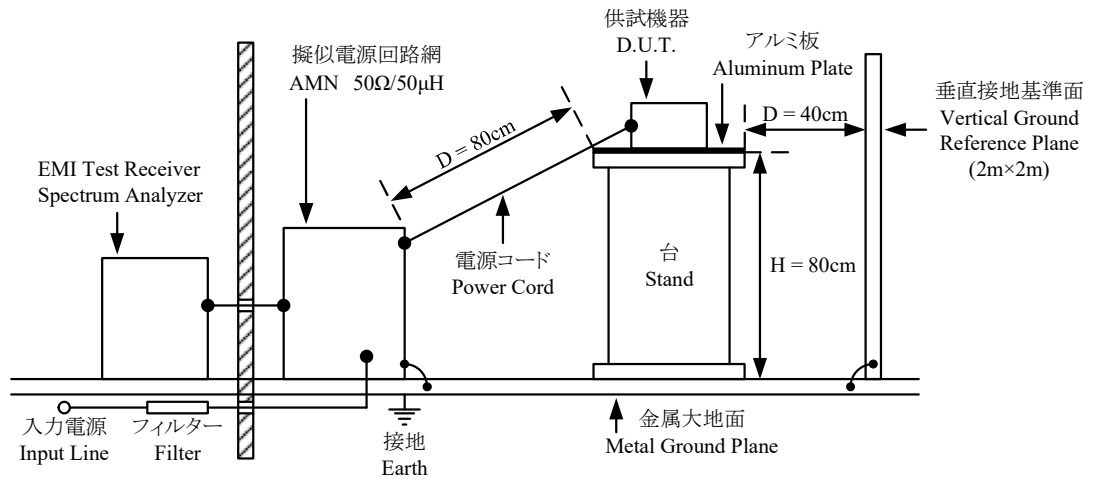

(b) 雑音電界強度(輻射ノイズ) Radiated Emission Noise

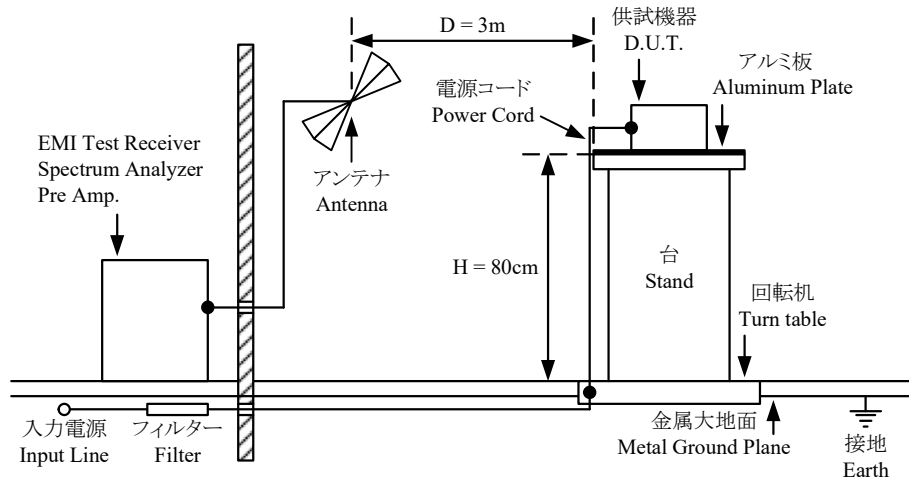

VCCI class A 対応アプリケーション VCCI class A application system

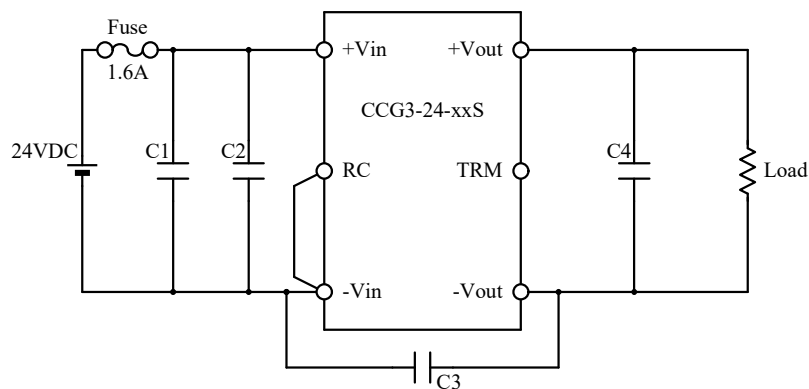

- |                 |                   |                       |
|-----------------|-------------------|-----------------------|
| C1 : 50V 10μF   | Ceramic Capacitor | (C3216X7R1H106K, TDK) |
| C2 : 50V 10μF   | Ceramic Capacitor | (C3216X7R1H106K, TDK) |
| C3 : 2kV 1000pF | Ceramic Capacitor | (C4520X7R3D102K, TDK) |
| C4 : 25V 10μF   | Ceramic Capacitor | (C3216X7R1E106K, TDK) |

## 1-2. 使用測定機器 List of equipment used

	EQUIPMENT USED	MANUFACTURER	MODEL NO.
1	DIGITAL STORAGE OSCILLOSCOPE	YOKOGAWA ELECT.	DL1740E / DL1740EL
2	DIGITAL MULTIMETER	AGILENT	34970A
3	CURRENT PROBE	YOKOGAWA ELECT.	701932
4	CURRENT PROBE	AGILENT	N2774A
5	SHUNT RESISTER	YOKOGAWA ELECT.	2215
6	DYNAMIC DUMMY LOAD	KIKUSUI	PLZ-164WL
7	CVCF	NF	ES10000S
8	DC POWER SUPPLY	TDK-Lambda	GEN80-9.5 / GENH80-9.5
9	DC POWER SUPPLY	TAKASAGO	EX-750H2
10	CONTROLLED TEMP. CHAMBER	ESPEC	SU-261 / SU-262
11	EMI TEST RECEIVER / SPECTRUM ANALYZER	ROHDE & SCHWARZ	ESR3
12	PRE AMP.	SONOMA	310N
13	AMN	KIKUSUI	KNW-242C
14	ANTENNA	SCHWARZBECK	BBA9106/VHA9103
15	ANTENNA	SCHWARZBECK	UHALP9107

## 2. 特性データ Characteristics

### 2-1. 静特性 Steady state characteristics

#### (1) 入力・負荷・温度変動 Regulation - line and load, Temperature drift

**3.3V**

#### 1. Regulation - line and load

Condition Ta : 25 °C

Io \ Vin	9VDC	12VDC	24VDC	36VDC	Line regulation	
0%	3.2940V	3.2941V	3.2941V	3.2941V	0.1mV	0.003%
50% (0.4A)	3.2937V	3.2937V	3.2938V	3.2938V	0.1mV	0.003%
100% (0.8A)	3.2935V	3.2935V	3.2935V	3.2936V	0.1mV	0.003%
Load regulation	0.5mV	0.6mV	0.6mV	0.5mV		
	0.015%	0.018%	0.018%	0.015%		

#### 2. Temperature drift

Conditions Vin : 24 VDC

Io : 100 %

Ta	-40°C	25°C	85°C	Temperature stability	
Vo	3.2931V	3.2935V	3.2930V	0.5mV	0.015%

**5V**

#### 1. Regulation - line and load

Condition Ta : 25 °C

Io \ Vin	9VDC	12VDC	24VDC	36VDC	Line regulation	
0%	4.9729V	4.9731V	4.9731V	4.9730V	0.2mV	0.004%
50% (0.3A)	4.9726V	4.9727V	4.9727V	4.9727V	0.1mV	0.002%
100% (0.6A)	4.9725V	4.9726V	4.9726V	4.9726V	0.1mV	0.002%
Load regulation	0.4mV	0.5mV	0.5mV	0.4mV		
	0.008%	0.010%	0.010%	0.008%		

#### 2. Temperature drift

Conditions Vin : 24 VDC

Io : 100 %

Ta	-40°C	25°C	85°C	Temperature stability	
Vo	4.9718V	4.9726V	4.9665V	6.1mV	0.122%

**12V**

#### 1. Regulation - line and load

Condition Ta : 25 °C

Io \ Vin	9VDC	12VDC	24VDC	36VDC	Line regulation	
0%	12.0149V	12.0151V	12.0150V	12.0149V	0.2mV	0.002%
50% (0.125A)	12.0145V	12.0145V	12.0145V	12.0145V	0.0mV	0.000%
100% (0.25A)	12.0140V	12.0140V	12.0144V	12.0142V	0.4mV	0.003%
Load regulation	0.9mV	1.1mV	0.6mV	0.7mV		
	0.008%	0.009%	0.005%	0.006%		

#### 2. Temperature drift

Conditions Vin : 24 VDC

Io : 100 %

Ta	-40°C	25°C	85°C	Temperature stability	
Vo	12.0351V	12.0144V	11.9886V	46.5mV	0.388%

**15V**

#### 1. Regulation - line and load

Condition Ta : 25 °C

Io \ Vin	9VDC	12VDC	24VDC	36VDC	Line regulation	
0%	15.1699V	15.1697V	15.1695V	15.1693V	0.6mV	0.004%
50% (0.1A)	15.1684V	15.1685V	15.1685V	15.1681V	0.4mV	0.003%
100% (0.2A)	15.1675V	15.1678V	15.1675V	15.1672V	0.6mV	0.004%
Load regulation	2.4mV	1.9mV	2.0mV	2.1mV		
	0.016%	0.013%	0.013%	0.014%		

#### 2. Temperature drift

Conditions Vin : 24 VDC

Io : 100 %

Ta	-40°C	25°C	85°C	Temperature stability	
Vo	15.2108V	15.1675V	15.0882V	122.6mV	0.817%

(2) 出力電圧・出力リップルノイズ電圧 対 入力電圧

Output voltage and Output ripple and noise voltage vs. Input voltage

Conditions Io : 100 %  
 Ta : -40 °C  
 : 25 °C  
 : 85 °C

3.3V

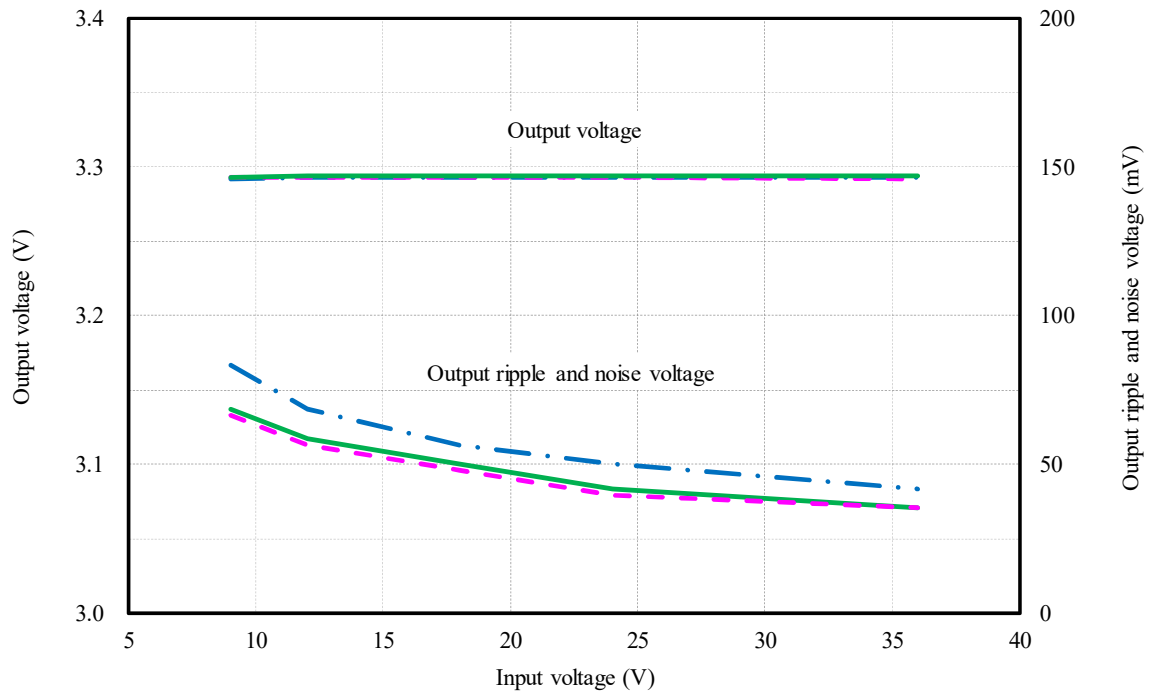

5V

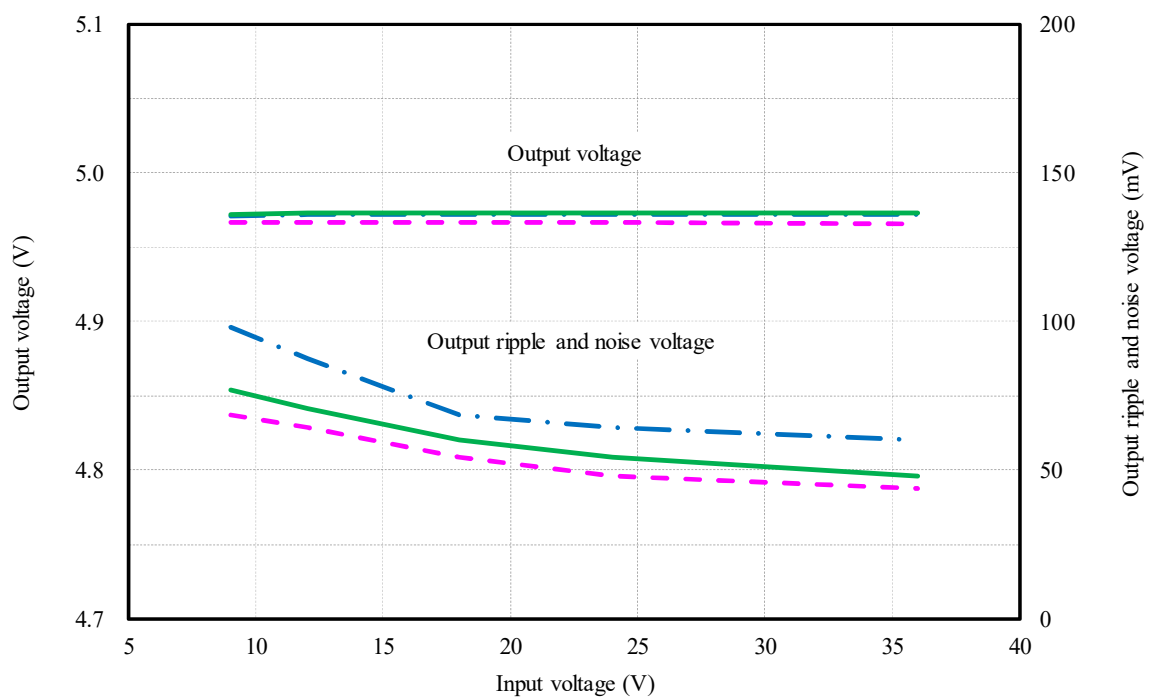

(2) 出力電圧・出力リップルノイズ電圧 対 入力電圧

Output voltage and Output ripple and noise voltage vs. Input voltage

Conditions Io : 100 %  
 Ta : -40 °C  
 : 25 °C  
 : 85 °C

12V

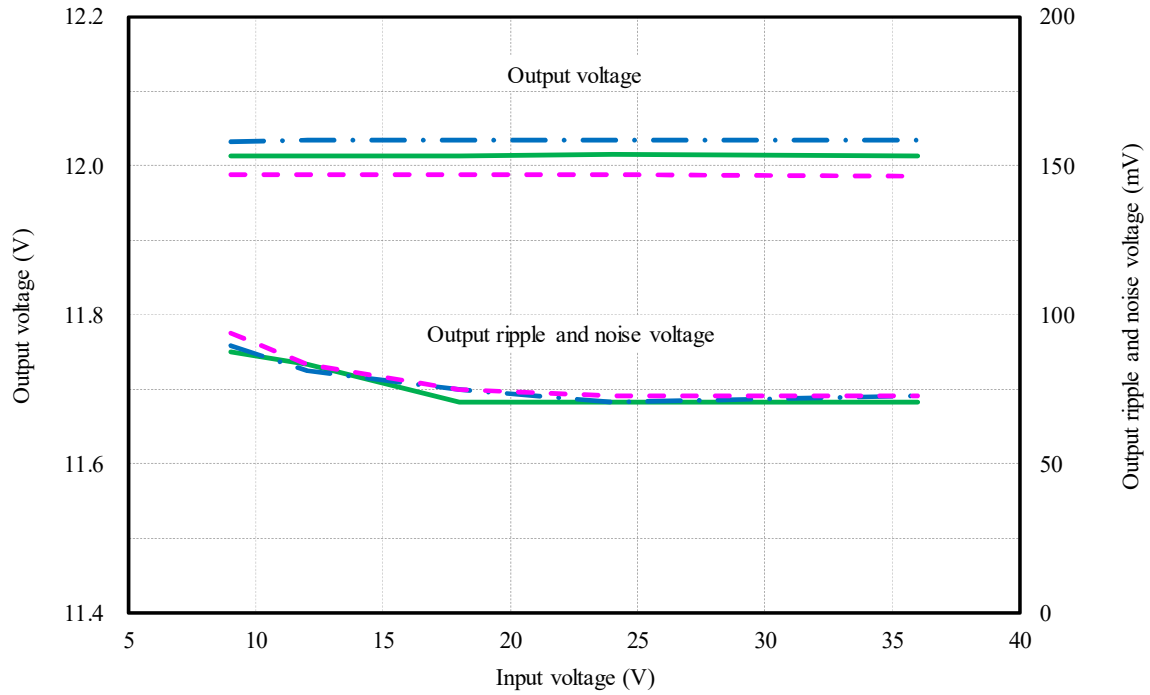

15V

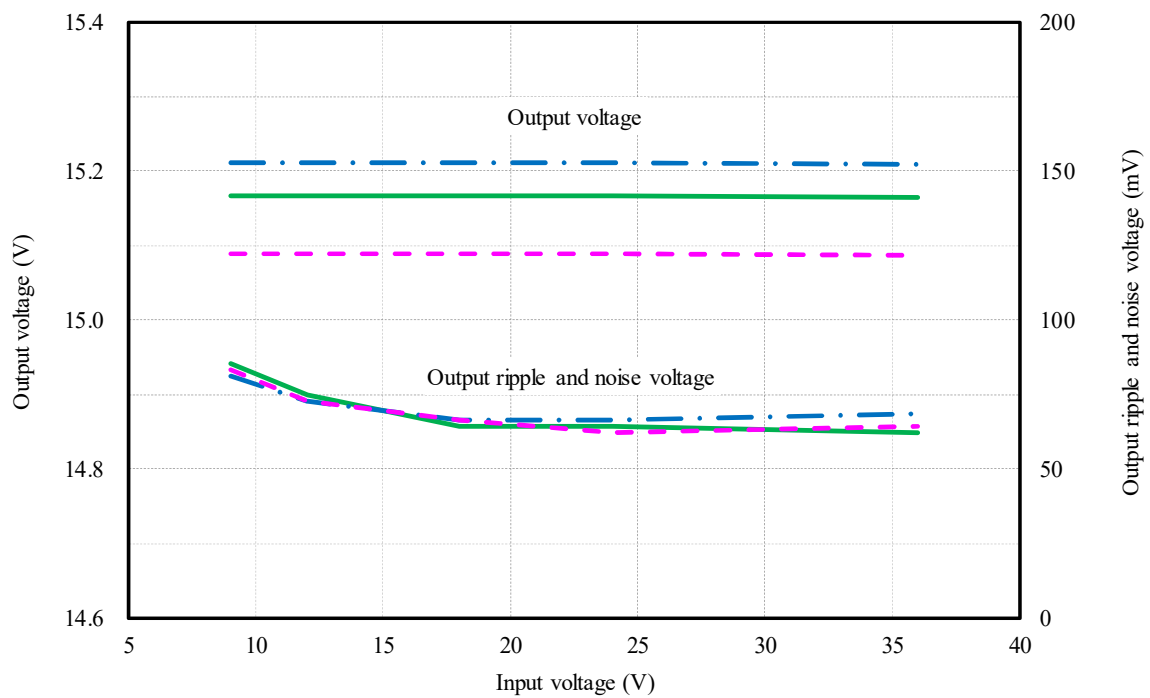



(3) 入力電流・効率 対 出力電流 Input current and Efficiency vs. Output current

Conditions Vin : 9 VDC ————  
 : 12 VDC - · - · -  
 : 24 VDC ————  
 : 36 VDC - · - · -  
 Ta : 25 °C

3.3V

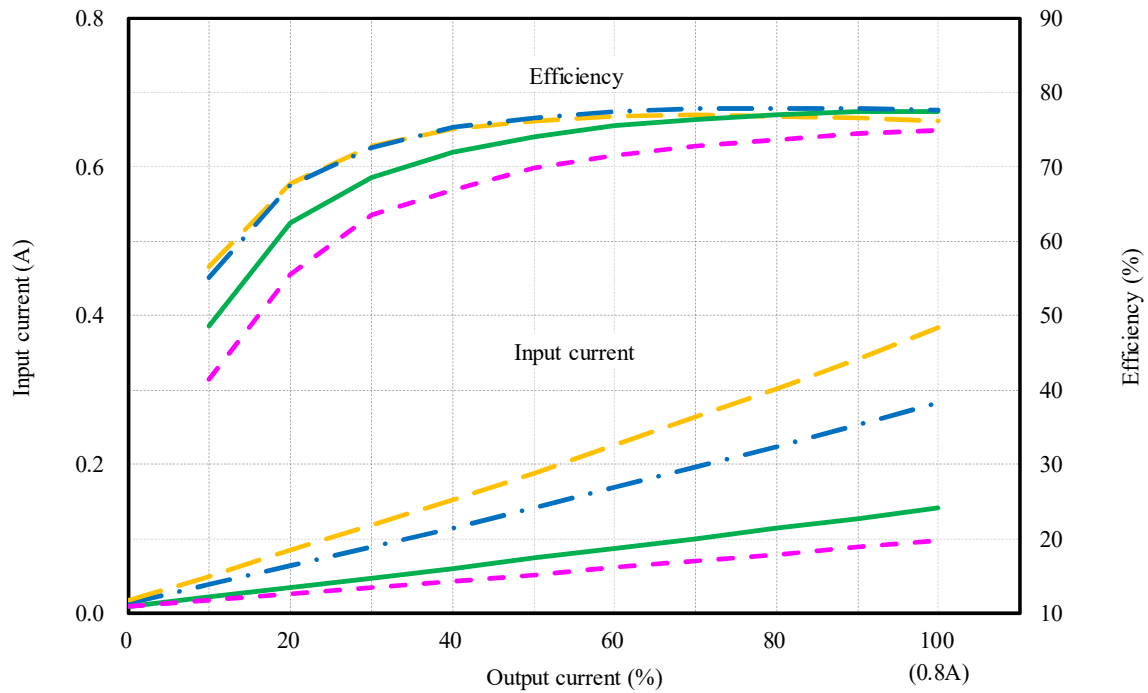

5V

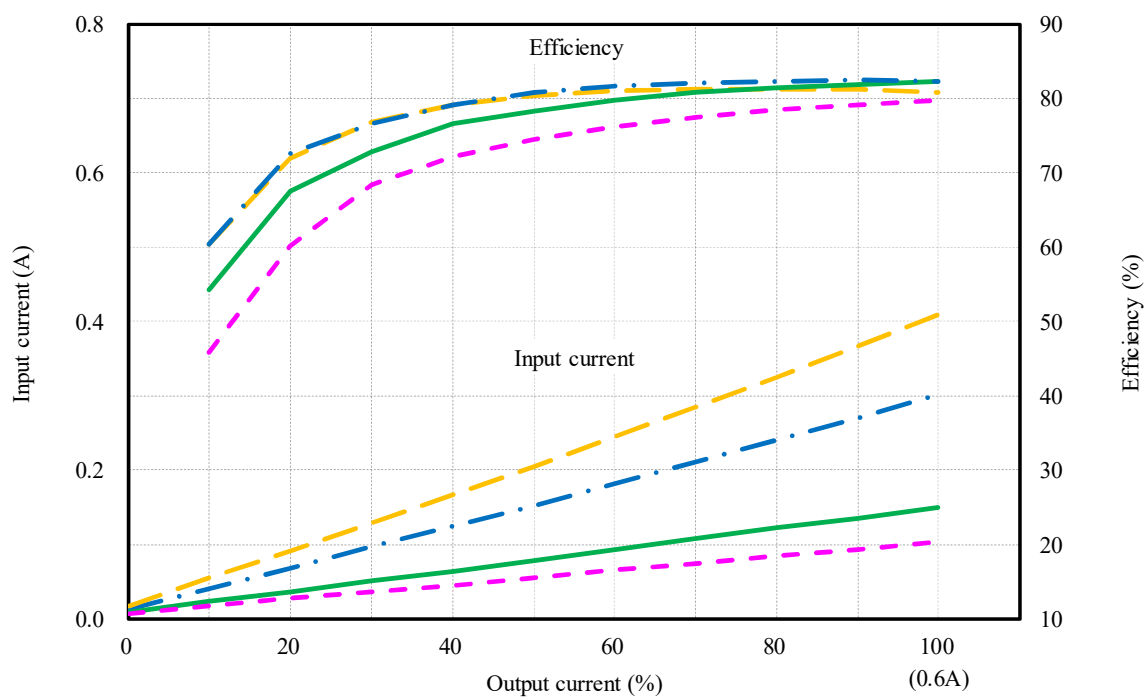

(3) 入力電流・効率 対 出力電流 Input current and Efficiency vs. Output current

Conditions Vin : 9 VDC ————  
 : 12 VDC - · - · -  
 : 24 VDC ————  
 : 36 VDC - · - · -  
 Ta : 25 °C

12V

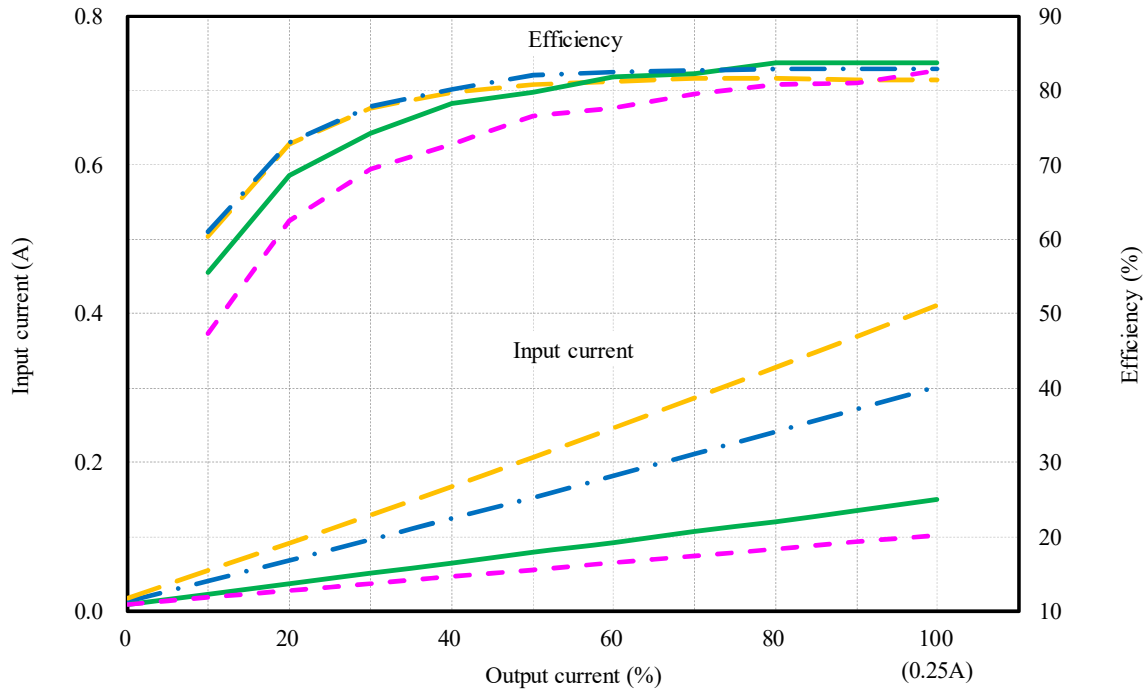

15V

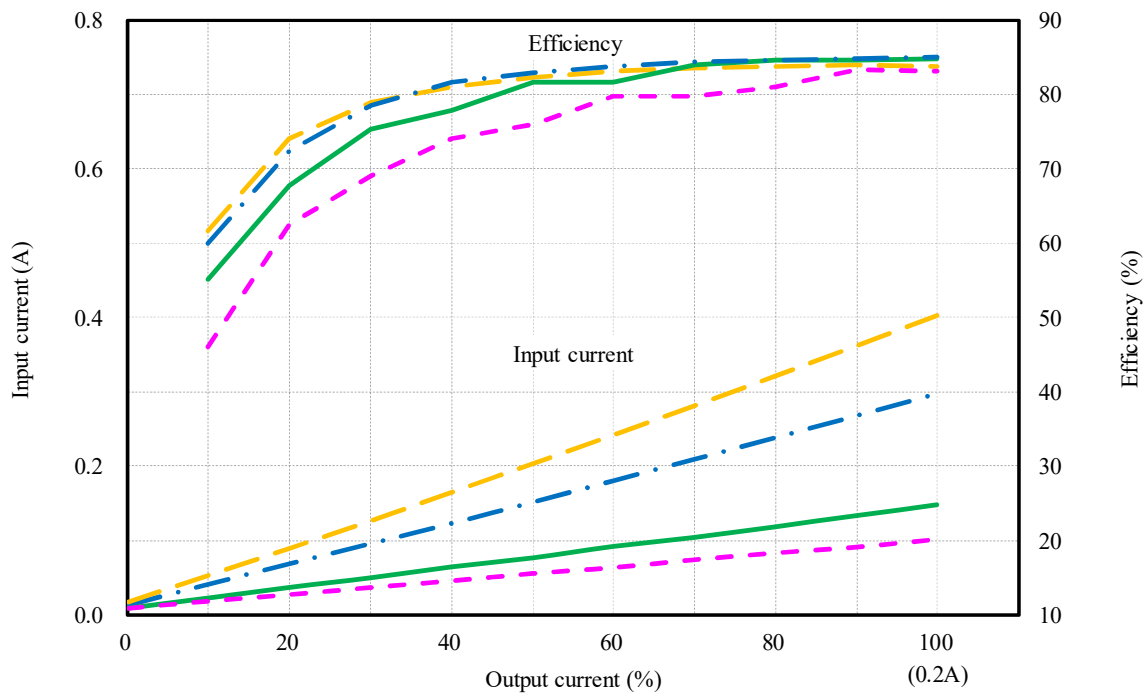

(4) 効率 対 入力電圧 Efficiency vs. Input voltage

Conditions Io : 50 % ---  
 : 100 % —  
 Ta : 25 °C

3.3V

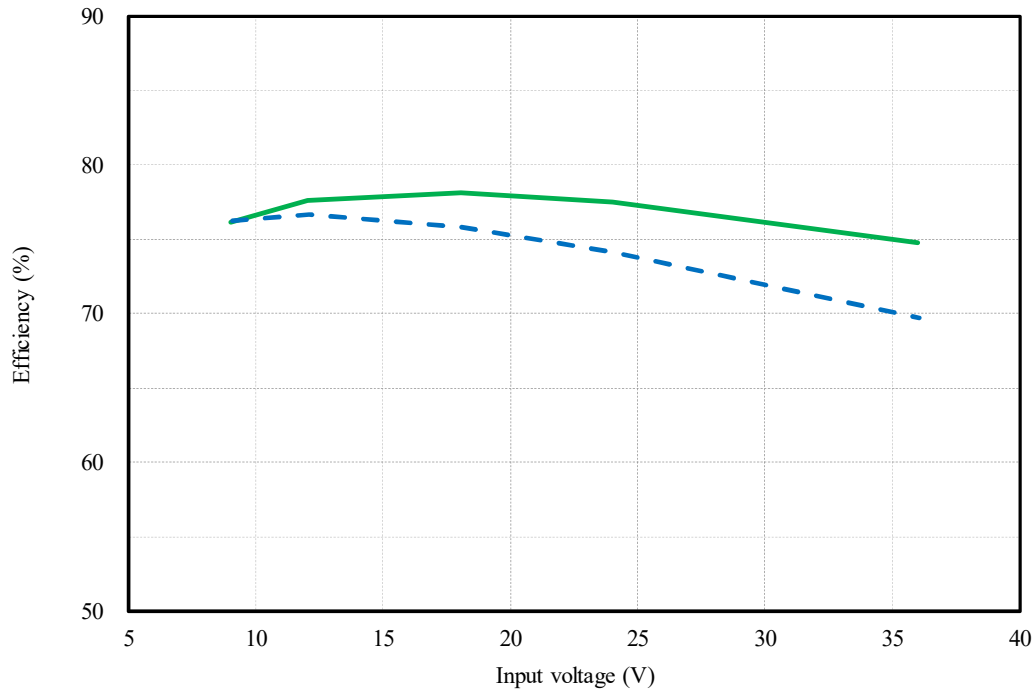

5V

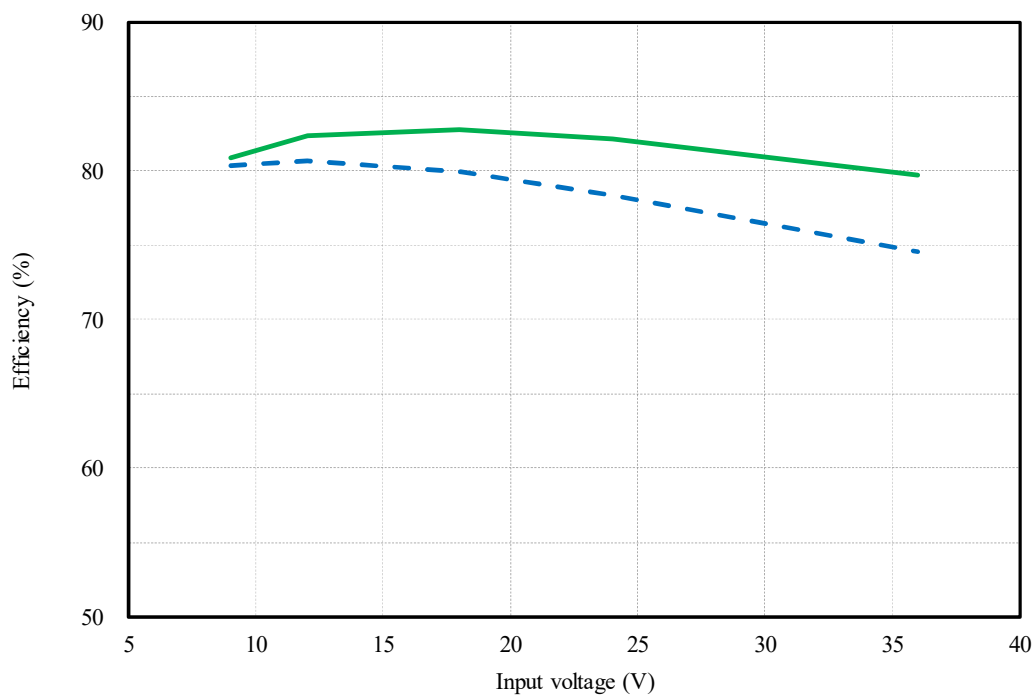

(4) 効率 対 入力電圧 Efficiency vs. Input voltage

Conditions Io : 50 % ---  
 : 100 % —  
 Ta : 25 °C

12V

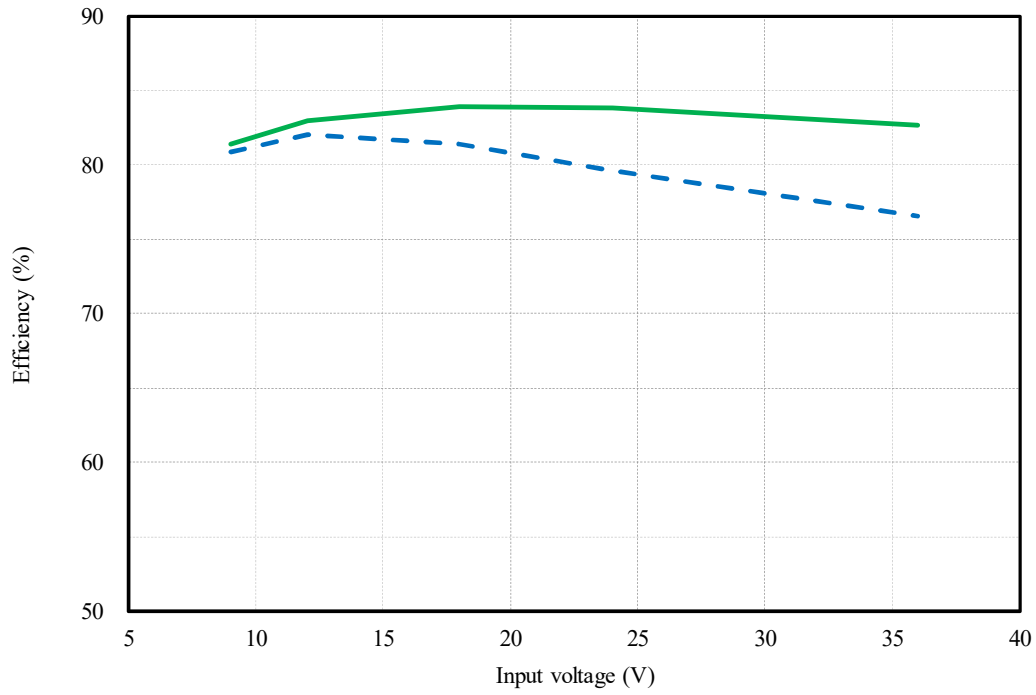

15V

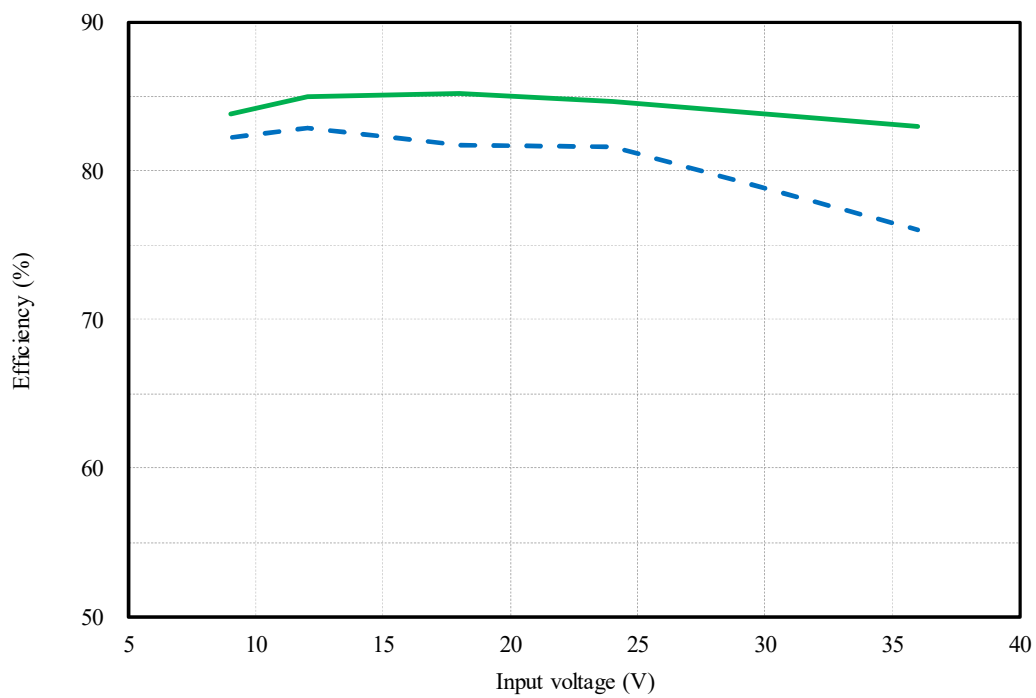

(5) 起動・遮断電圧特性 Start up and Drop out voltage characteristics

出力電圧 対 入力電圧

Output voltage vs. Input voltage

Conditions  $I_o$  : 100 %  
 $T_a$  : 25 °C

入力電流 対 入力電圧

Input current vs. Input voltage

Conditions  $I_o$  : 100 %  
 $T_a$  : 25 °C

3.3V

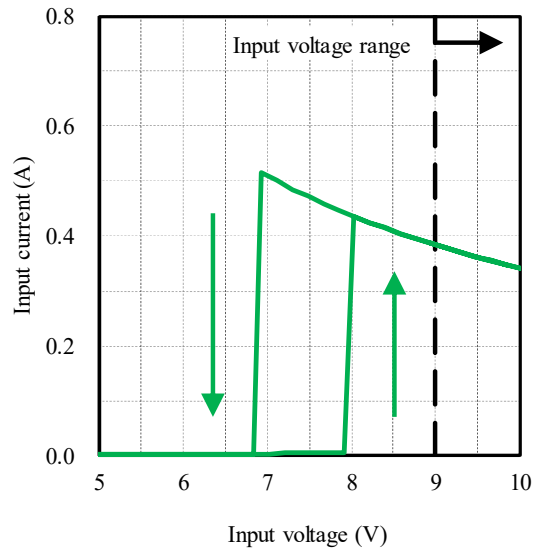
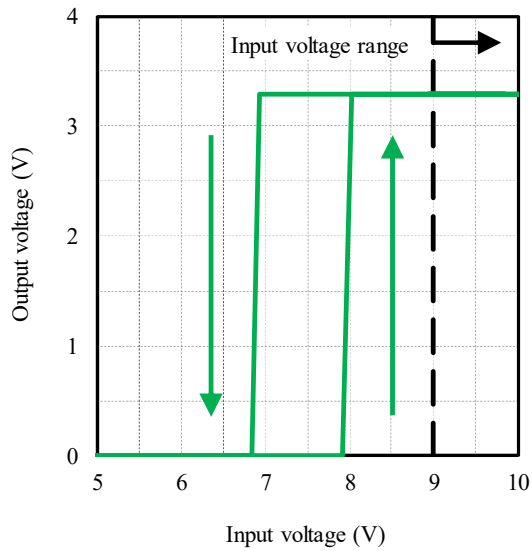

5V

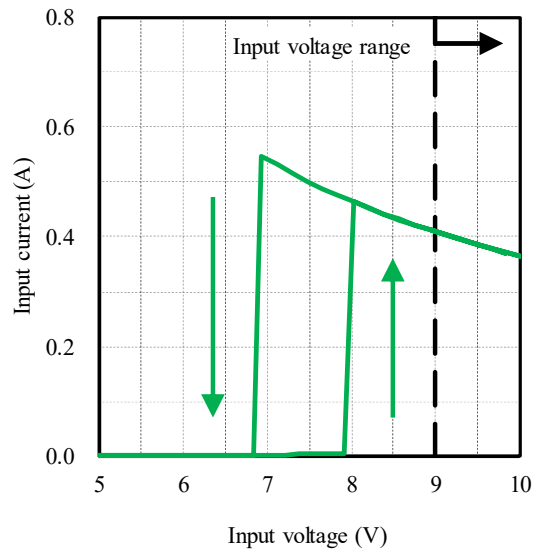
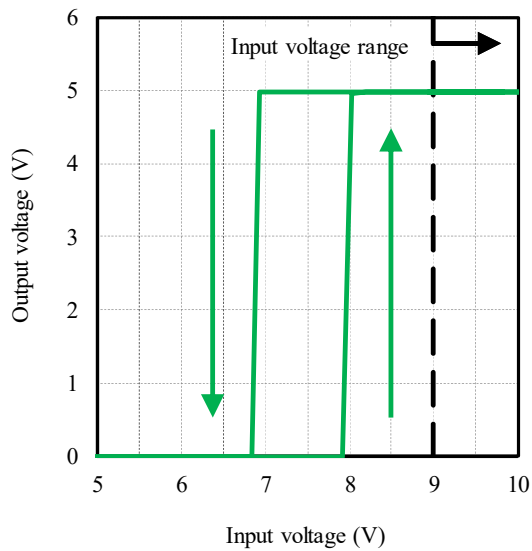

(5) 起動・遮断電圧特性 Start up and Drop out voltage characteristics

出力電圧 対 入力電圧

Output voltage vs. Input voltage

Conditions  $I_o$  : 100 %  
 $T_a$  : 25 °C

入力電流 対 入力電圧

Input current vs. Input voltage

Conditions  $I_o$  : 100 %  
 $T_a$  : 25 °C

12V

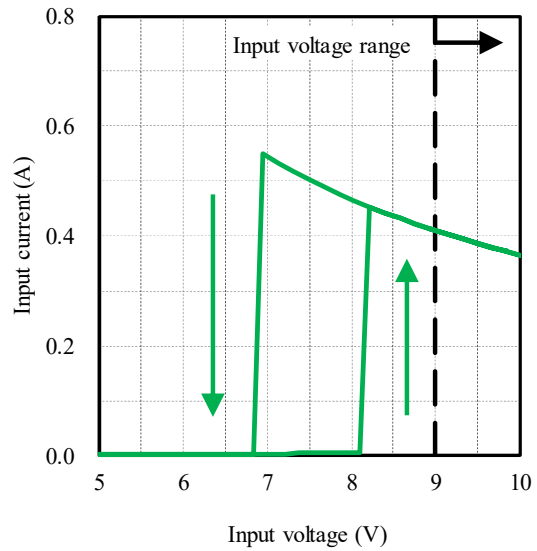
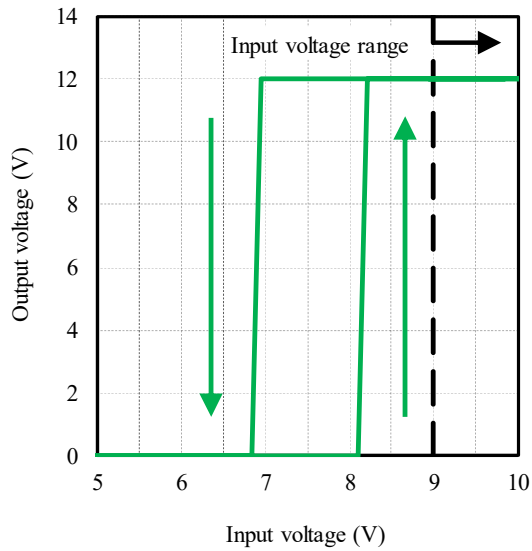

15V

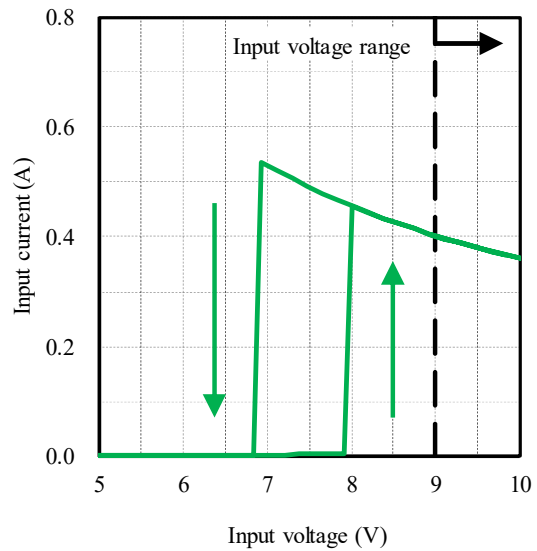
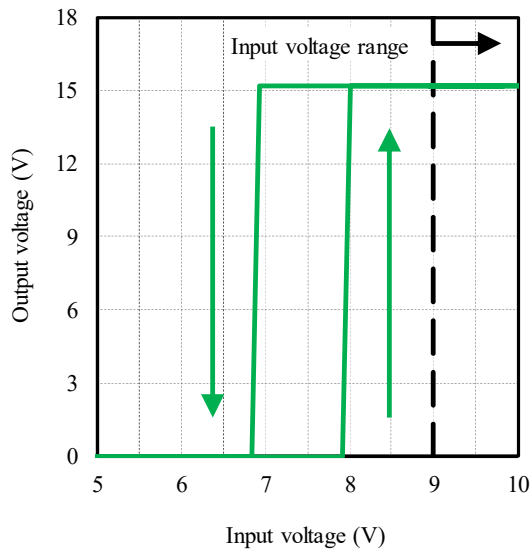

2-2. 待機電力特性 Standby power characteristics

Condition Ta : 25 °C

3.3V

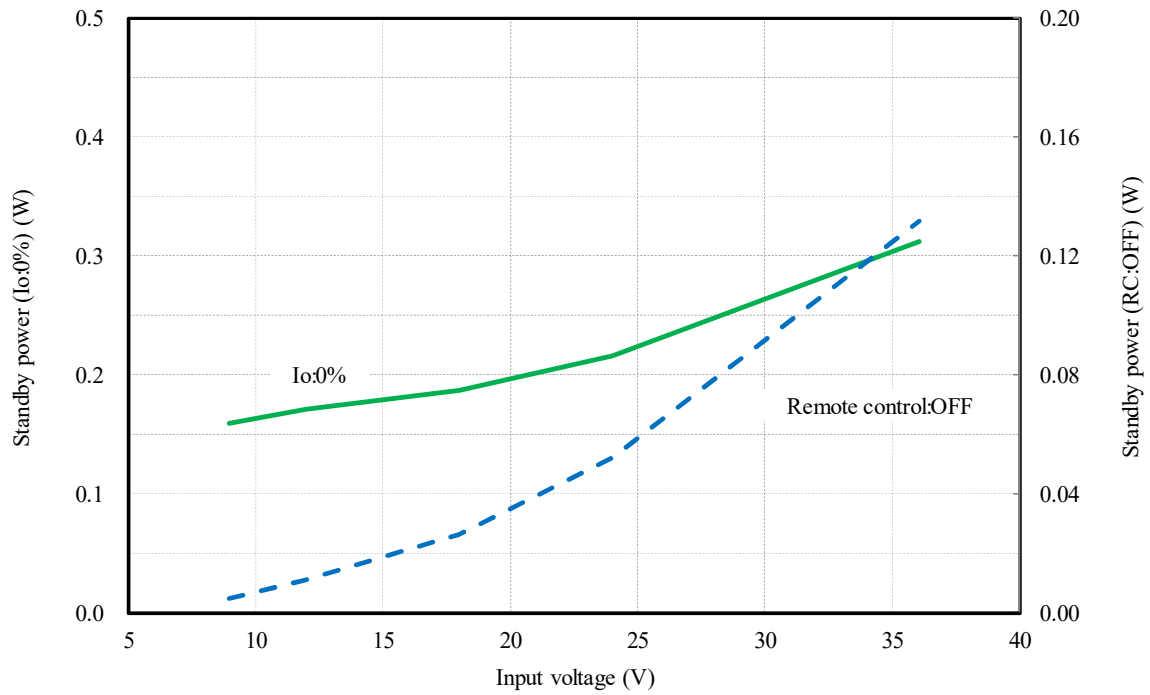

5V

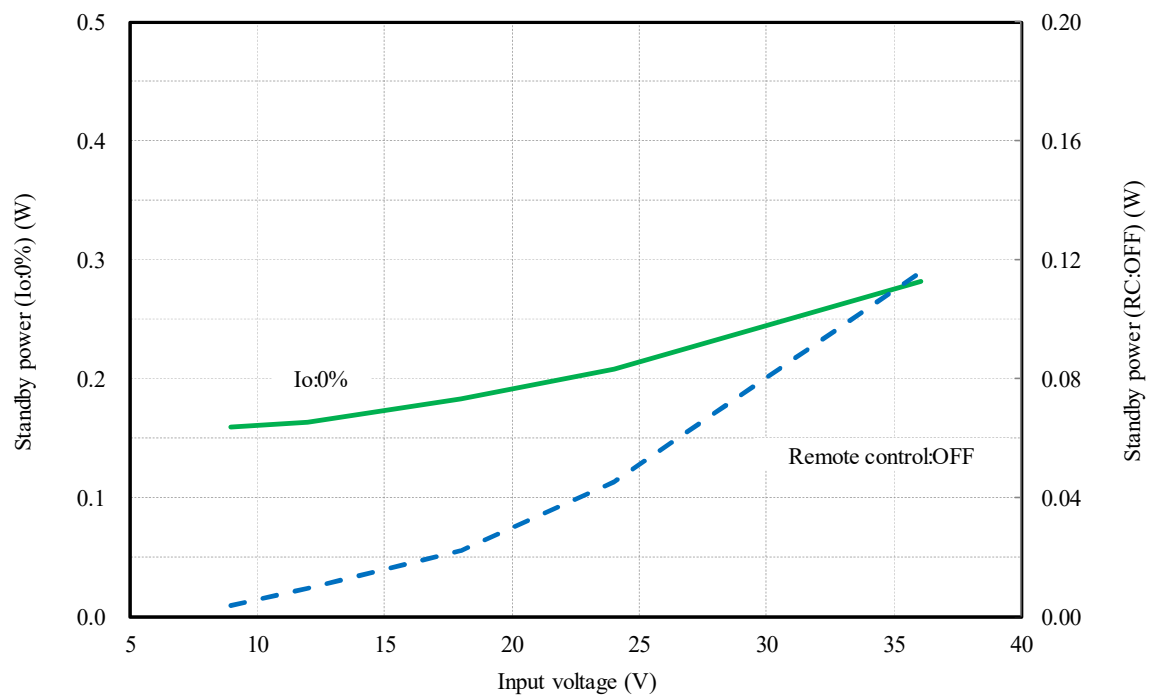

2-2. 待機電力特性 Standby power characteristics

Condition Ta : 25 °C

12V

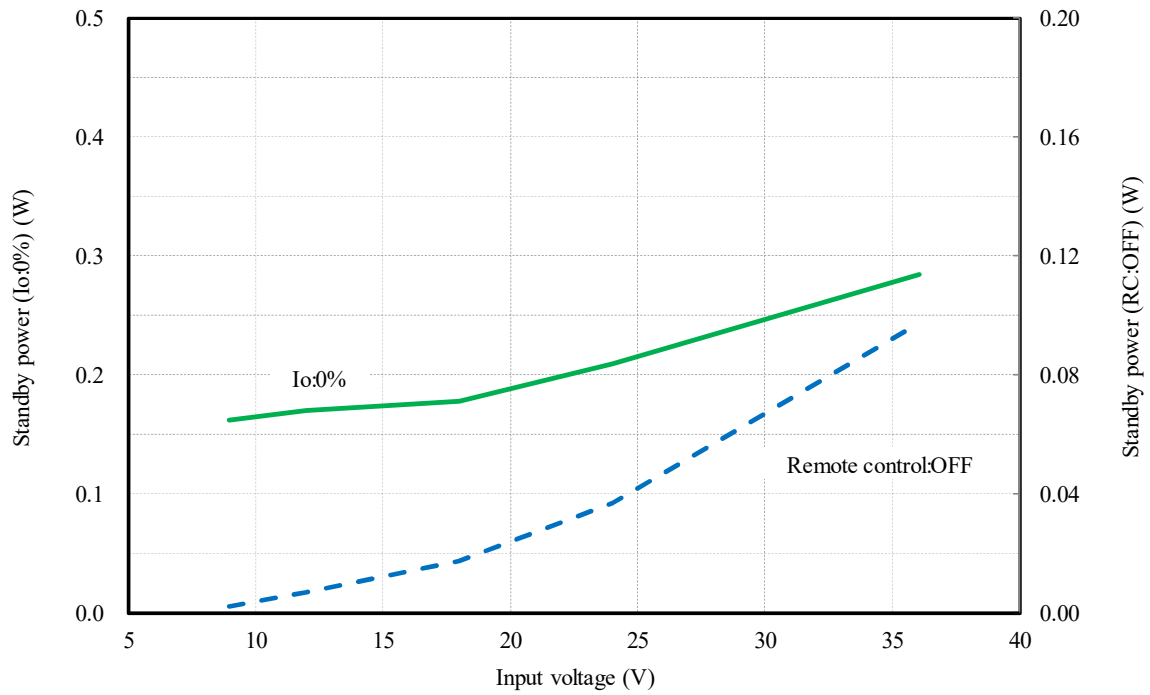

15V

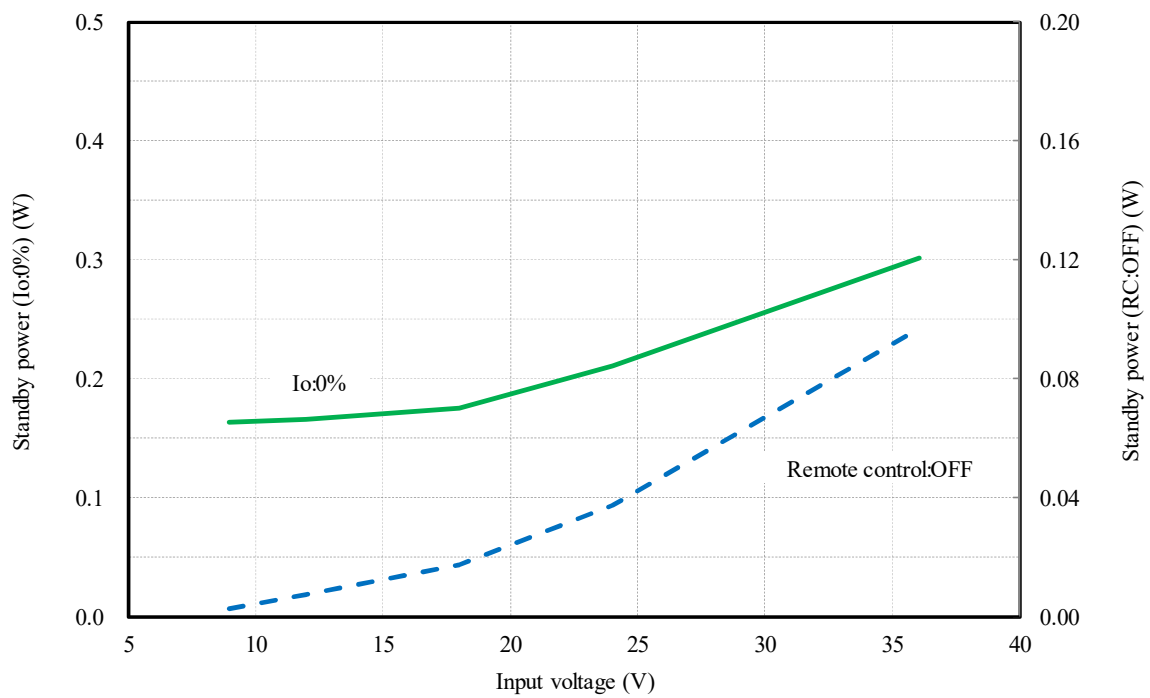



2-3. 通電ドリフト特性 Warm up voltage drift characteristics

Conditions Vin : 24 VDC  
Io : 100 %  
Ta : 25 °C

3.3V

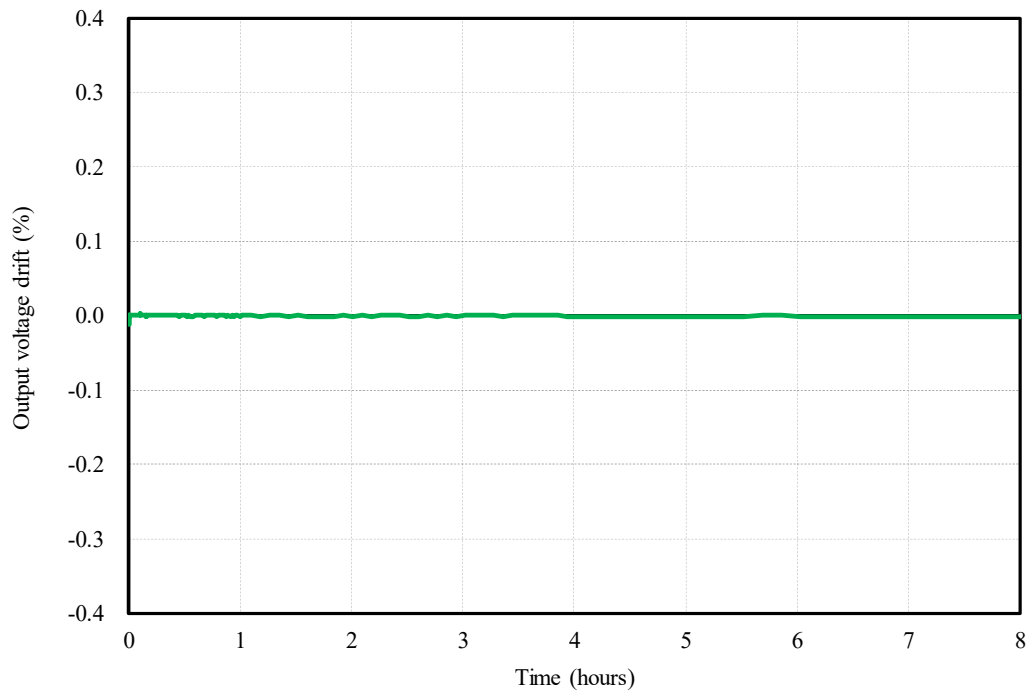

5V

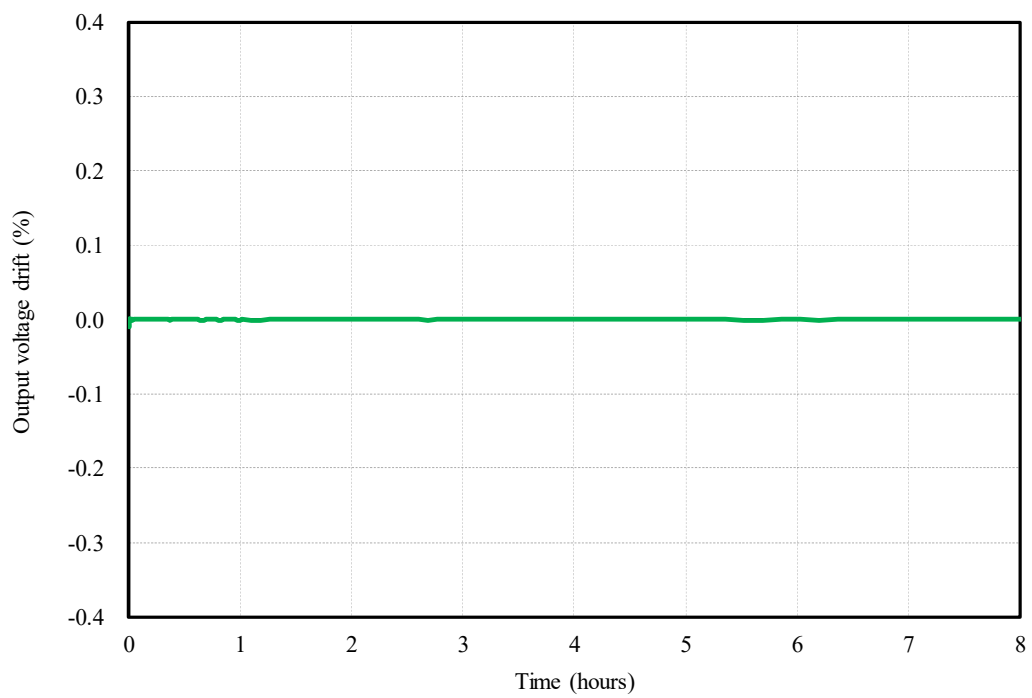

2-3. 通電ドリフト特性 Warm up voltage drift characteristics

Conditions Vin : 24 VDC  
Io : 100 %  
Ta : 25 °C

12V

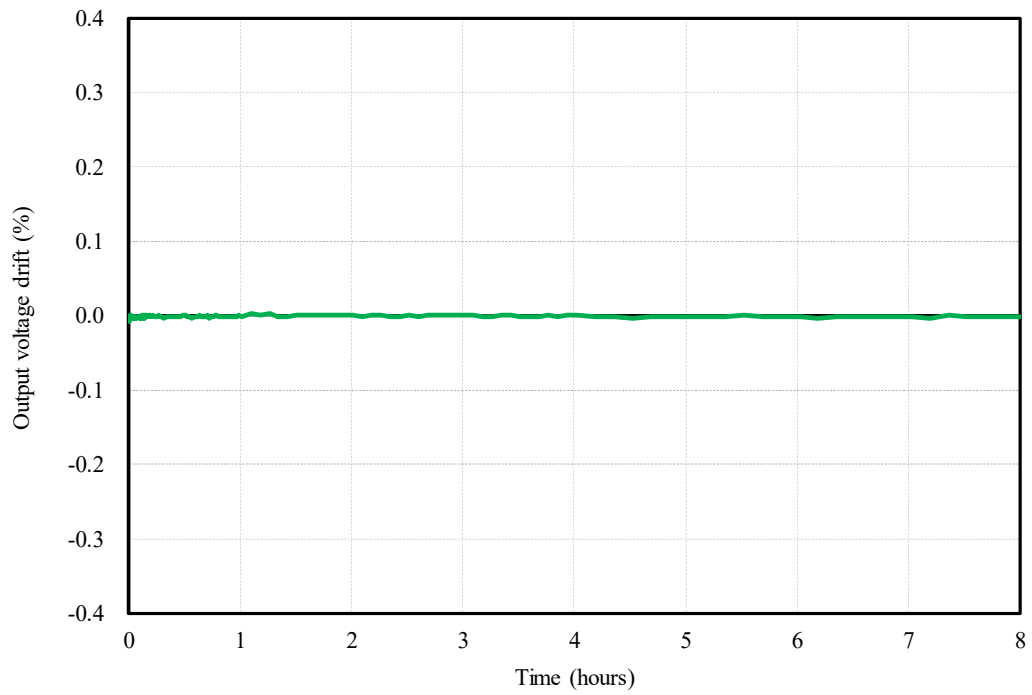

15V

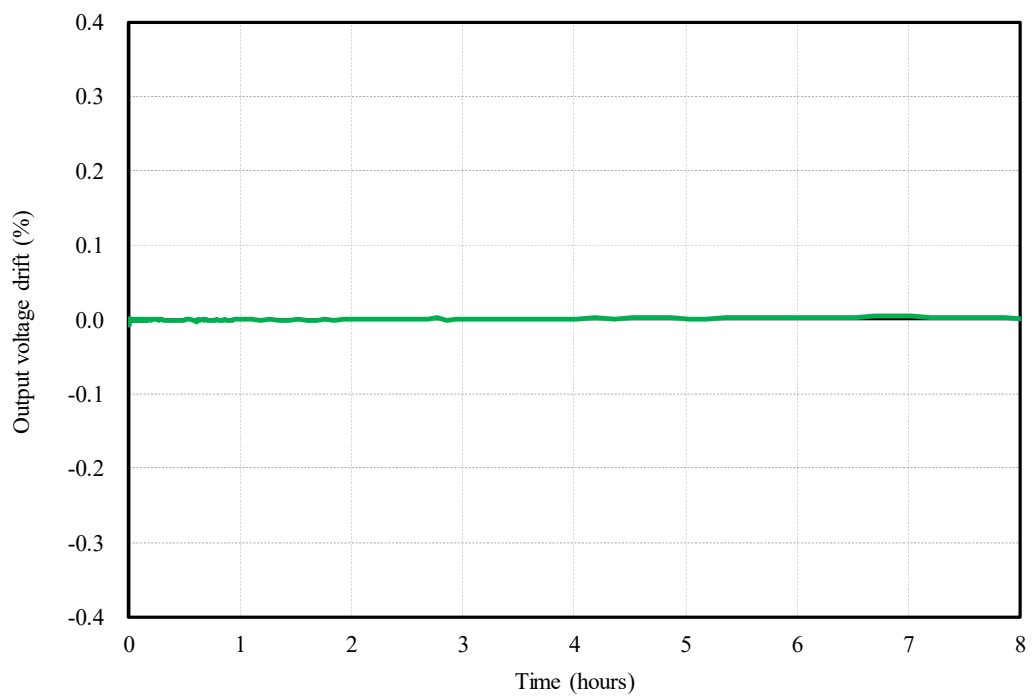

2-4. 過電流保護特性 Over current protection (OCP) characteristics

入力電圧依存性

Input voltage dependence

Conditions Vin : 9 VDC ———  
 : 12 VDC - - -  
 : 24 VDC ———  
 : 36 VDC - - -  
 Ta : 25 °C

周囲温度依存性

Ambient temperature dependence

Conditions Vin : 24 VDC  
 Ta : -40 °C - - -  
 : 25 °C ———  
 : 85 °C - - -

3.3V

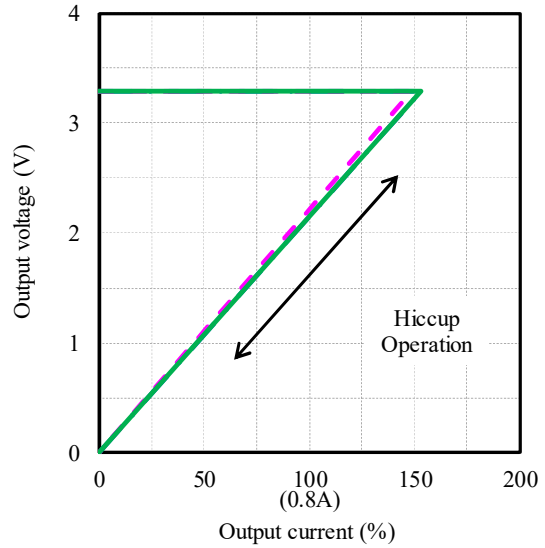
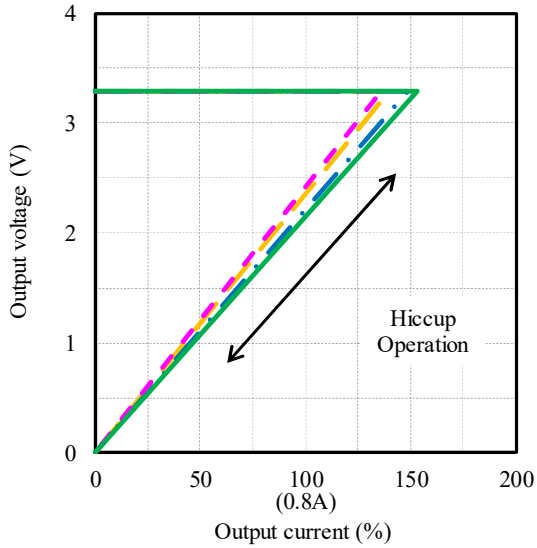

5V

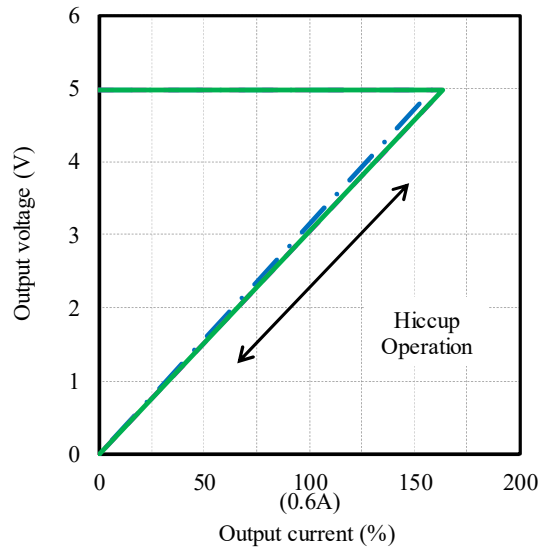
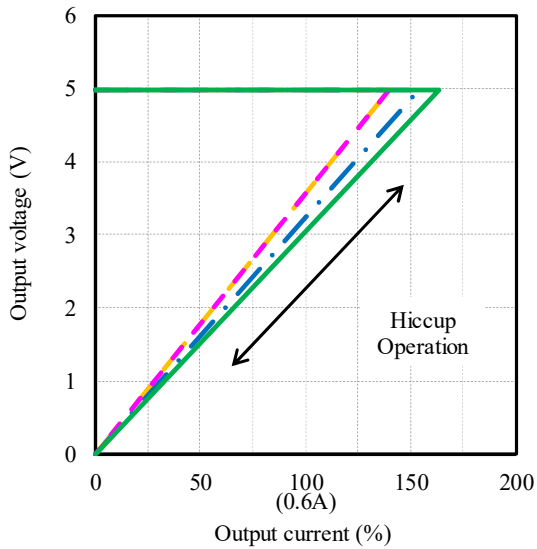

2-4. 過電流保護特性 Over current protection (OCP) characteristics

入力電圧依存性

Input voltage dependence

Conditions Vin : 9 VDC ———  
 : 12 VDC - - -  
 : 24 VDC ———  
 : 36 VDC - - -  
 Ta : 25 °C

周囲温度依存性

Ambient temperature dependence

Conditions Vin : 24 VDC  
 Ta : -40 °C - - -  
 : 25 °C ———  
 : 85 °C - - -

12V

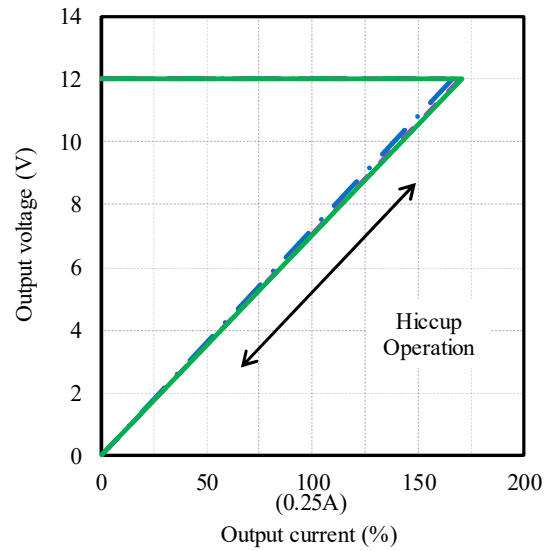
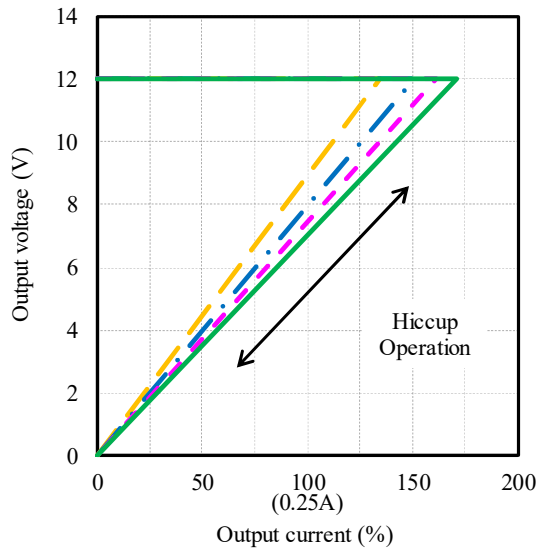

15V

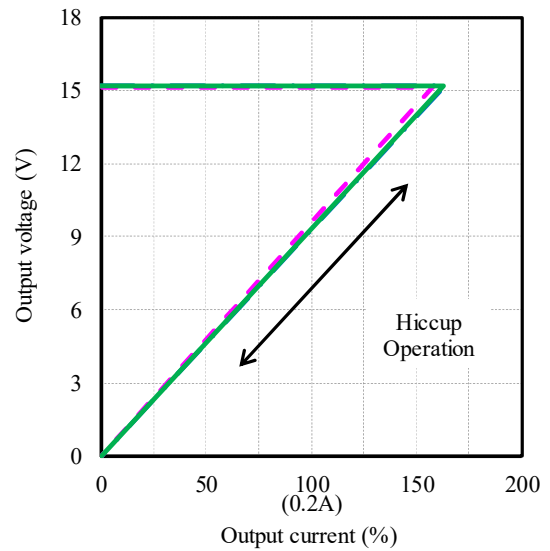
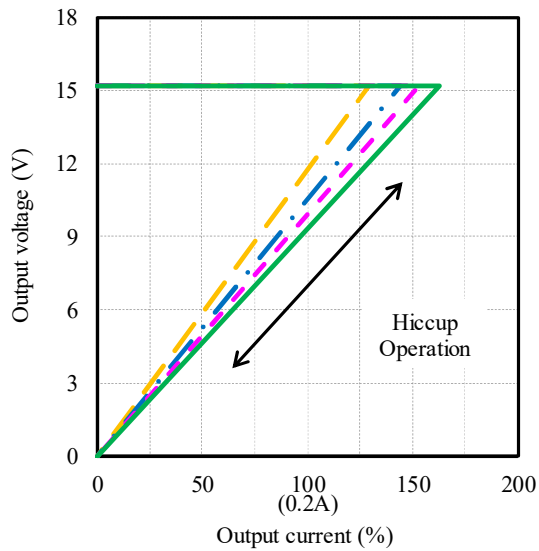

2-5. 出力立ち上がり・立ち下がり特性 Output rise and fall characteristics

Conditions  $V_{in}$  : 24 VDC  
 $I_o$  : 0 %  
 $T_a$  : 25 °C

3.3V

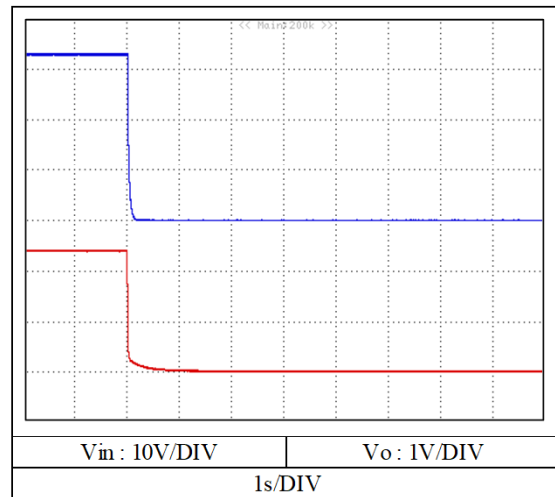
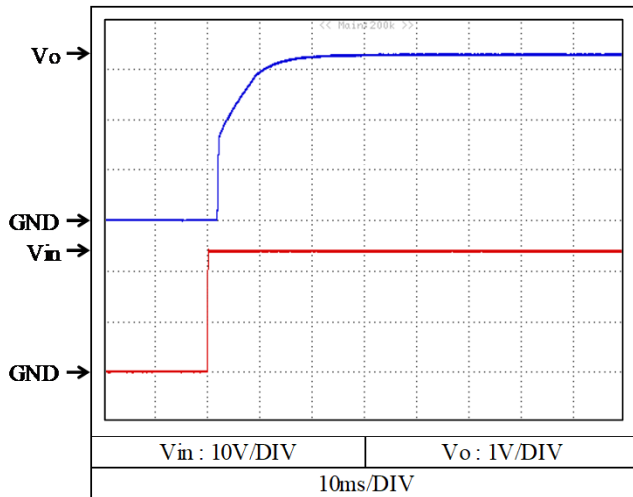

5V

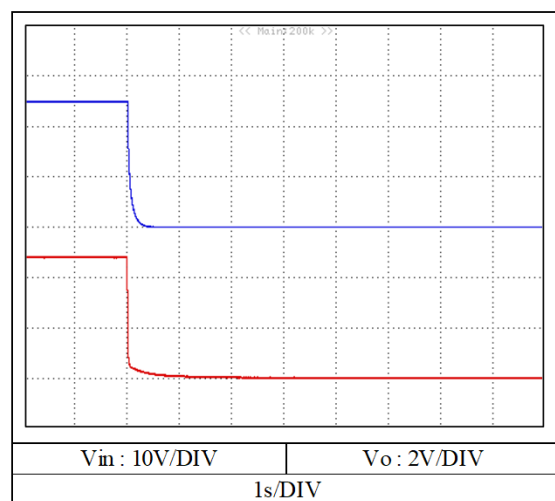
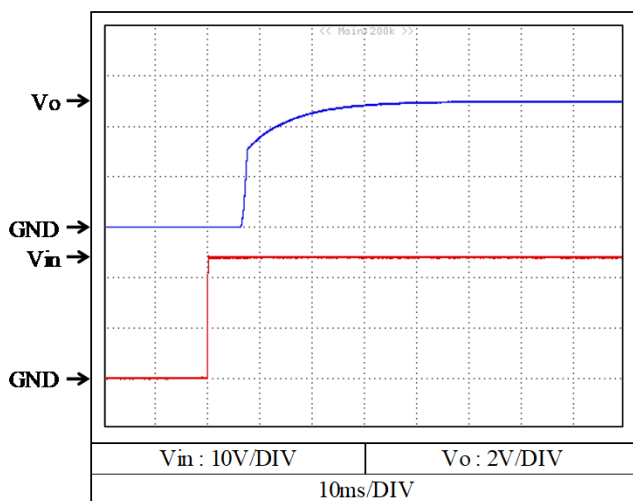

2-5. 出力立ち上がり・立ち下がり特性 Output rise and fall characteristics

Conditions  $V_{in}$  : 24 VDC  
 $I_o$  : 0 %  
 $T_a$  : 25 °C

12V

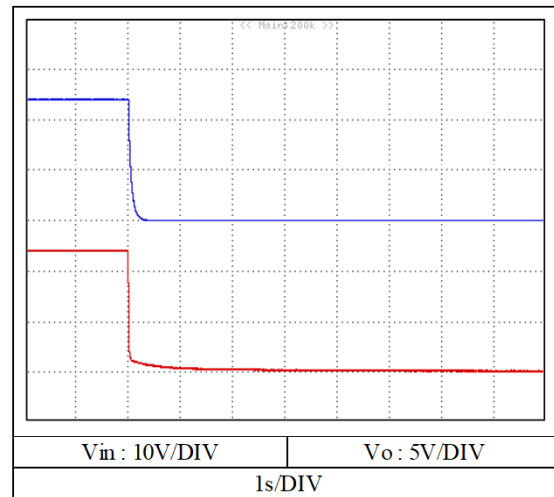
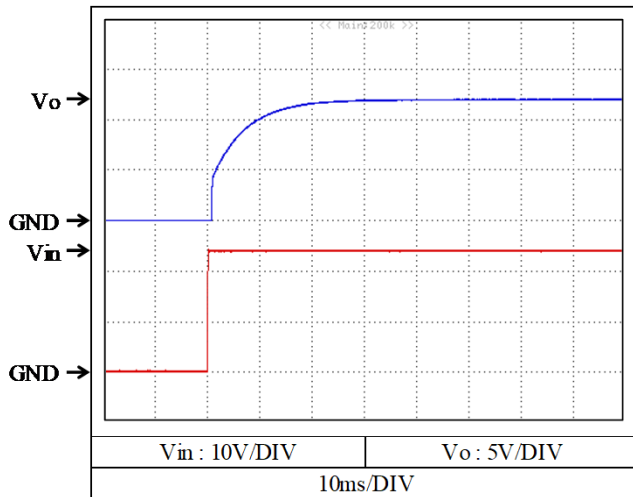

15V

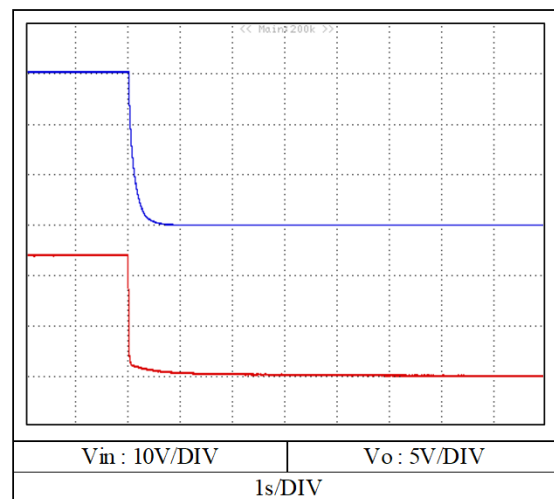
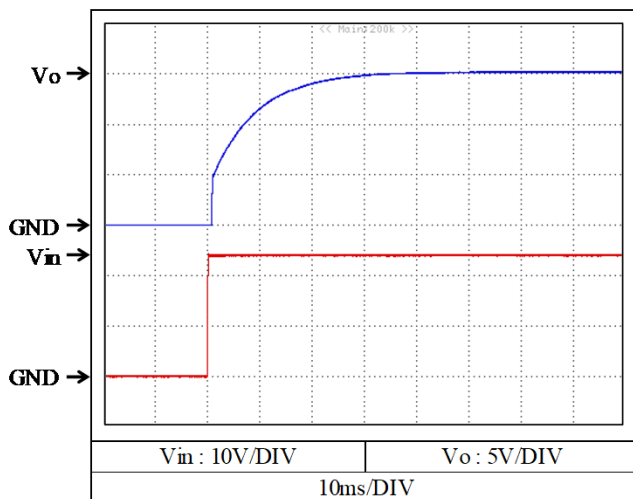

2-5. 出力立ち上がり・立ち下がり特性 Output rise and fall characteristics

Conditions  $V_{in}$  : 24 VDC  
 $I_o$  : 100 %  
 $T_a$  : 25 °C

3.3V

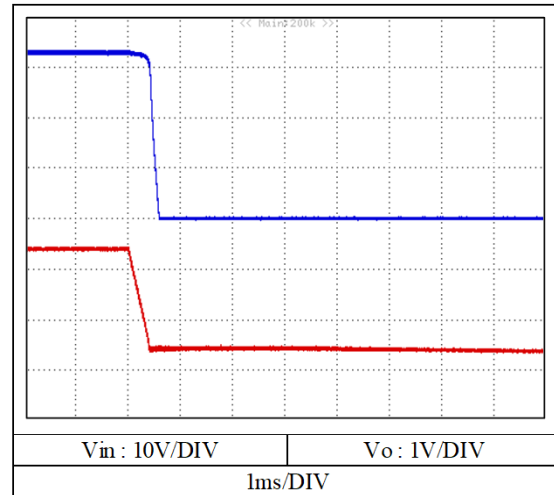
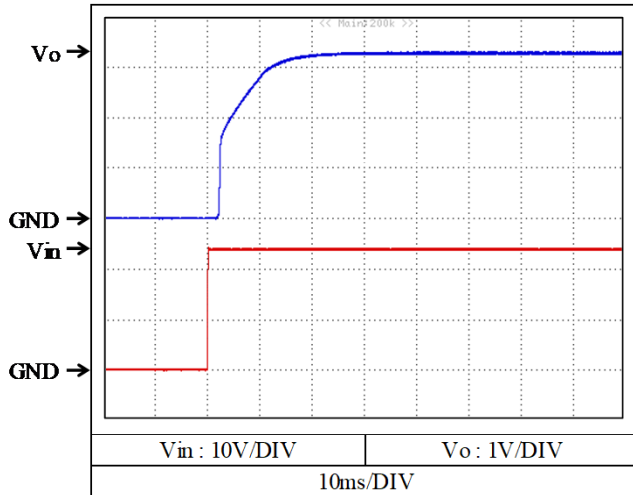

5V

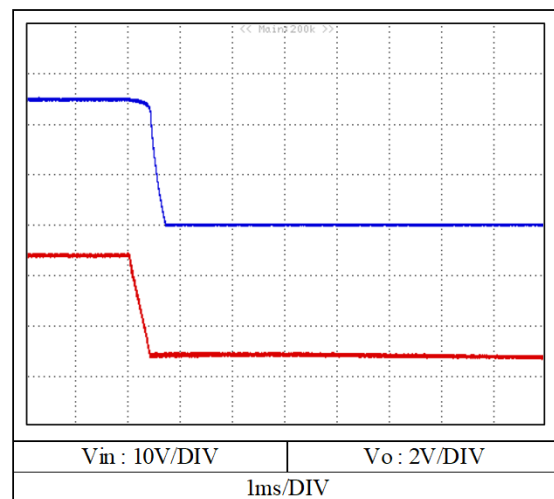
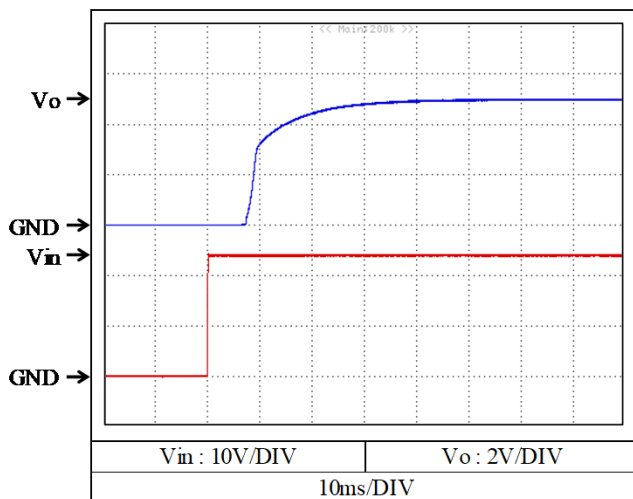

2-5. 出力立ち上がり・立ち下がり特性 Output rise and fall characteristics

Conditions  $V_{in}$  : 24 VDC  
 $I_o$  : 100 %  
 $T_a$  : 25 °C

12V

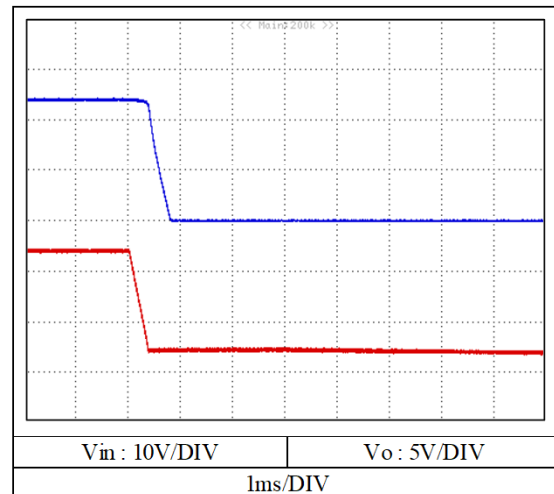
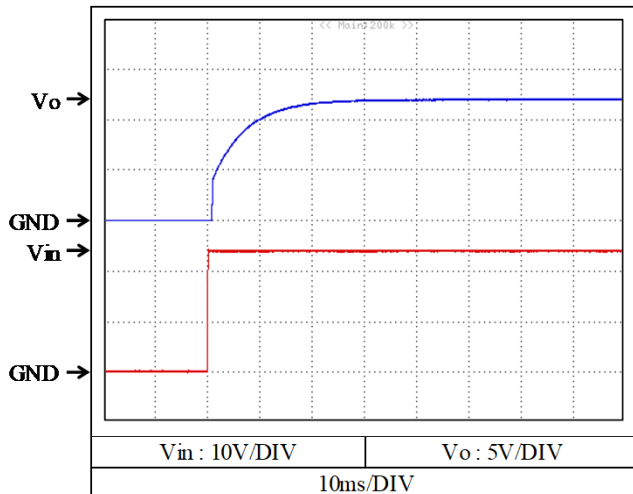

15V

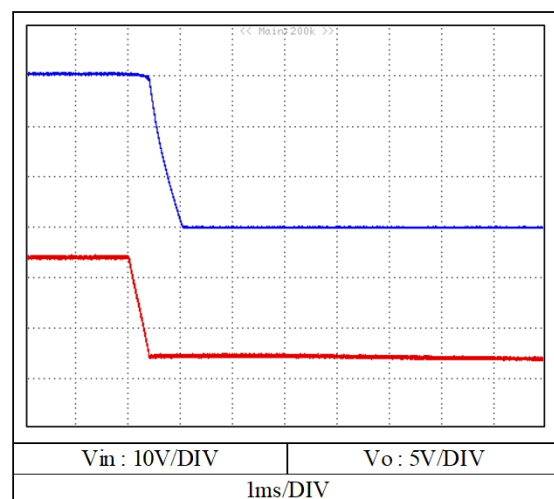
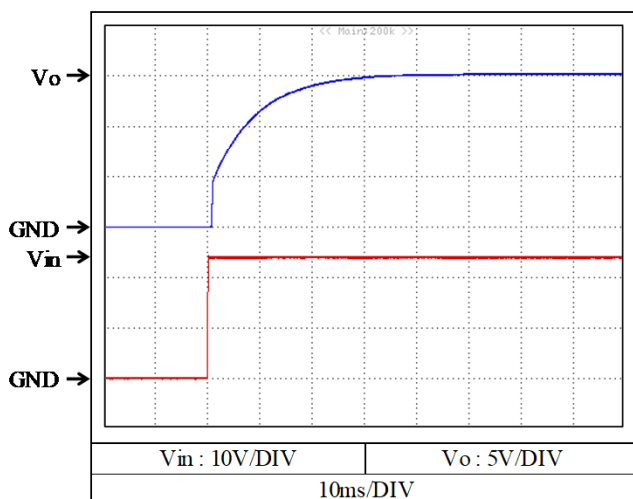



2-5. 出力立ち上がり・立ち下がり特性 (リモートON/OFFコントロール時)

Output rise and fall characteristics with REMOTE ON/OFF CONTROL

Conditions  $V_{in}$  : 24 VDC  
 $I_o$  : 0 %  
 $T_a$  : 25 °C

3.3V

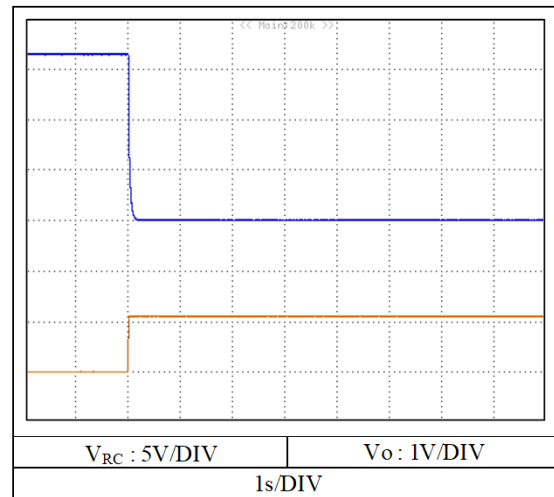
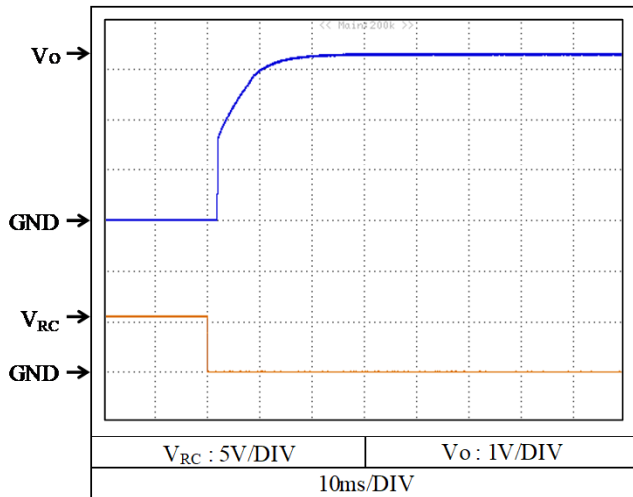

5V

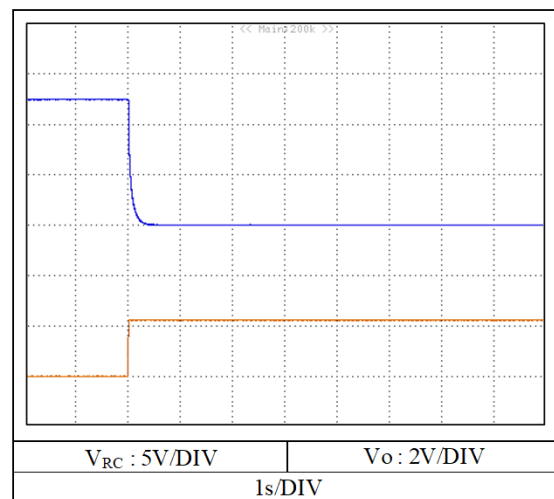
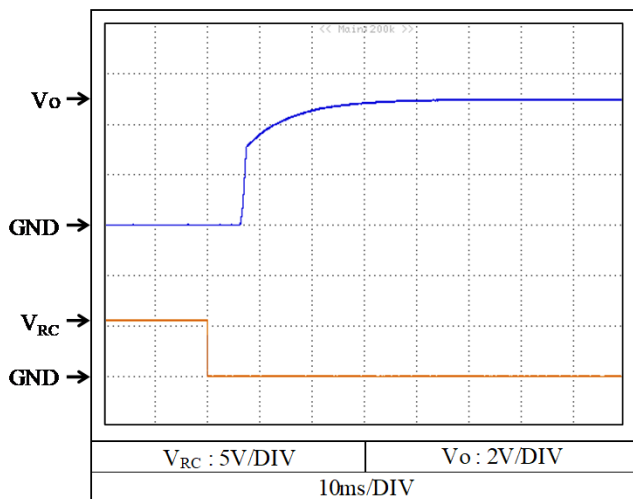

2-5. 出力立ち上がり・立ち下がり特性 (リモートON/OFFコントロール時)

Output rise and fall characteristics with REMOTE ON/OFF CONTROL

Conditions  $V_{in}$  : 24 VDC  
 $I_o$  : 0 %  
 $T_a$  : 25 °C

12V

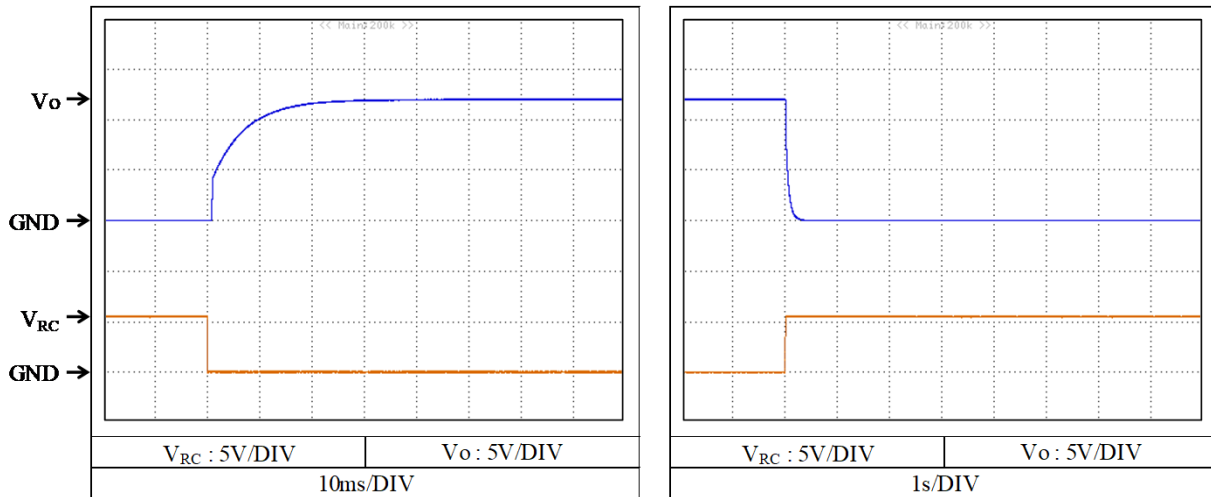

15V

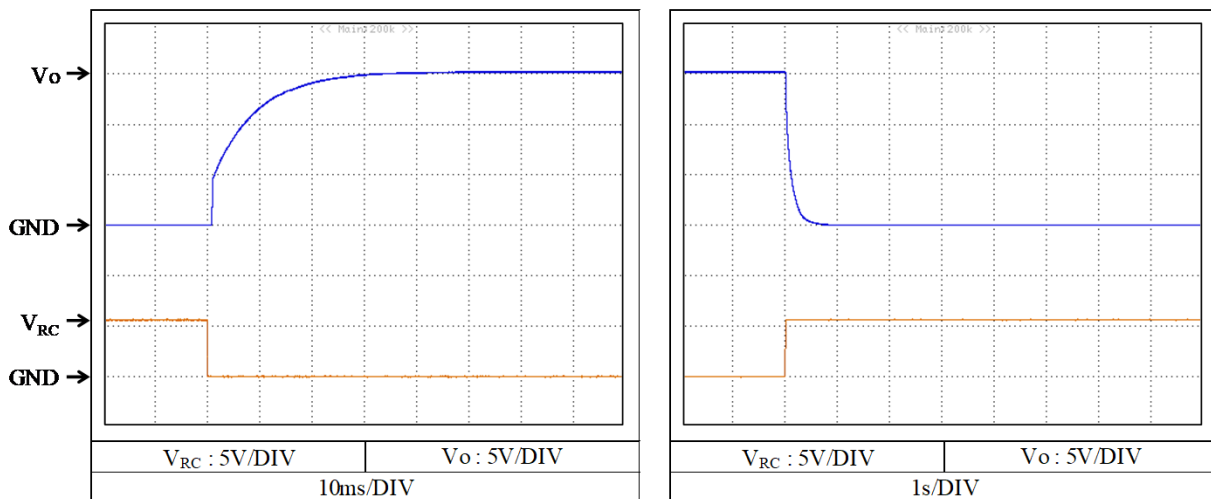

2-5. 出力立ち上がり・立ち下がり特性 (リモートON/OFFコントロール時)

Output rise and fall characteristics with REMOTE ON/OFF CONTROL

Conditions  $V_{in}$  : 24 VDC  
 $I_o$  : 100 %  
 $T_a$  : 25 °C

3.3V

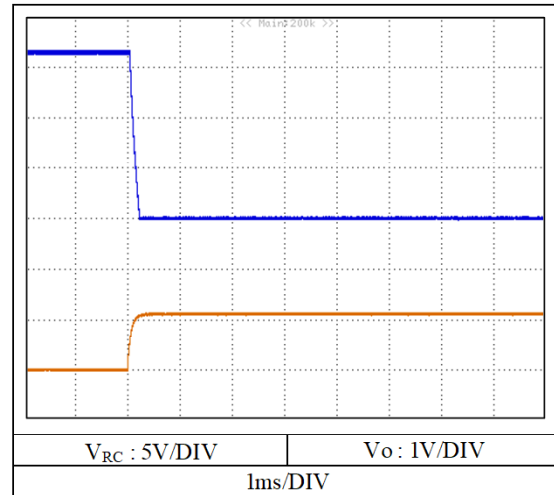
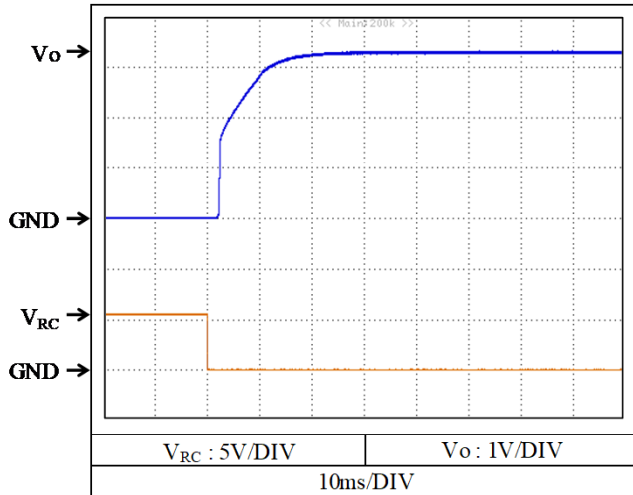

5V

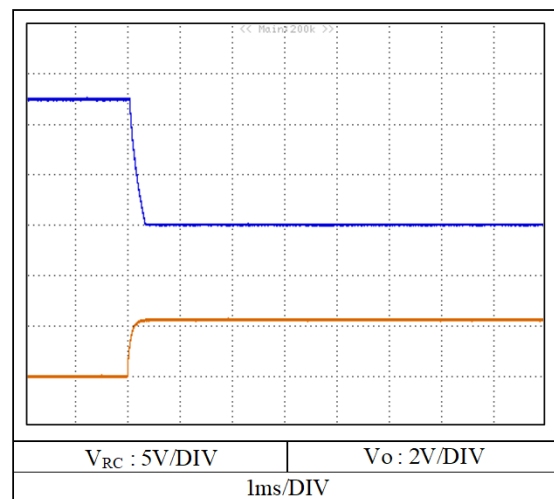
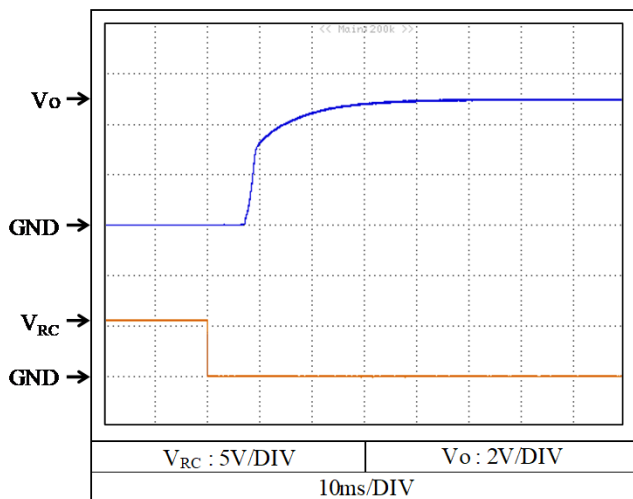

2-5. 出力立ち上がり・立ち下がり特性 (リモートON/OFFコントロール時)

Output rise and fall characteristics with REMOTE ON/OFF CONTROL

Conditions  $V_{in}$  : 24 VDC  
 $I_o$  : 100 %  
 $T_a$  : 25 °C

12V

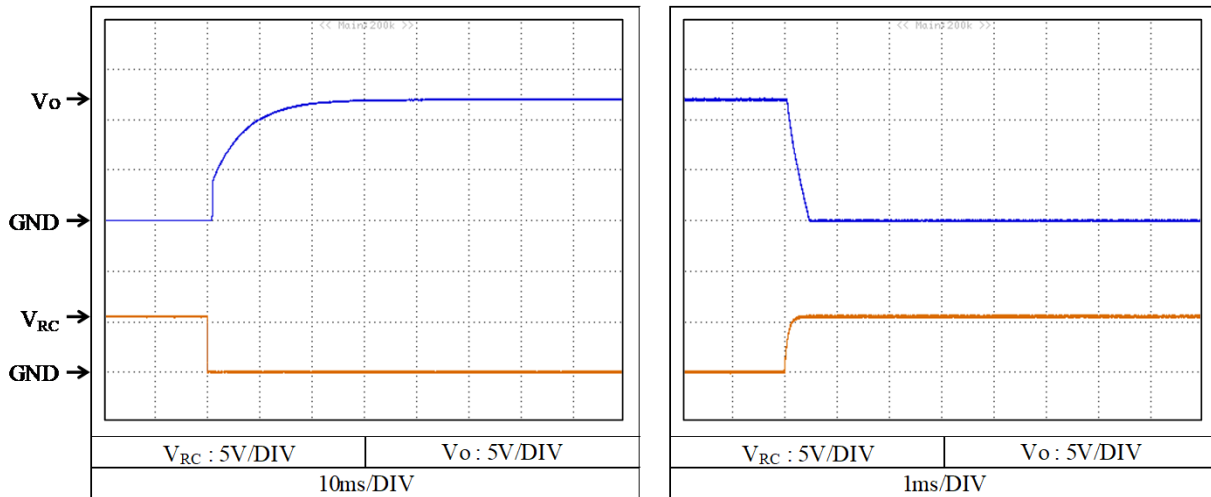

15V

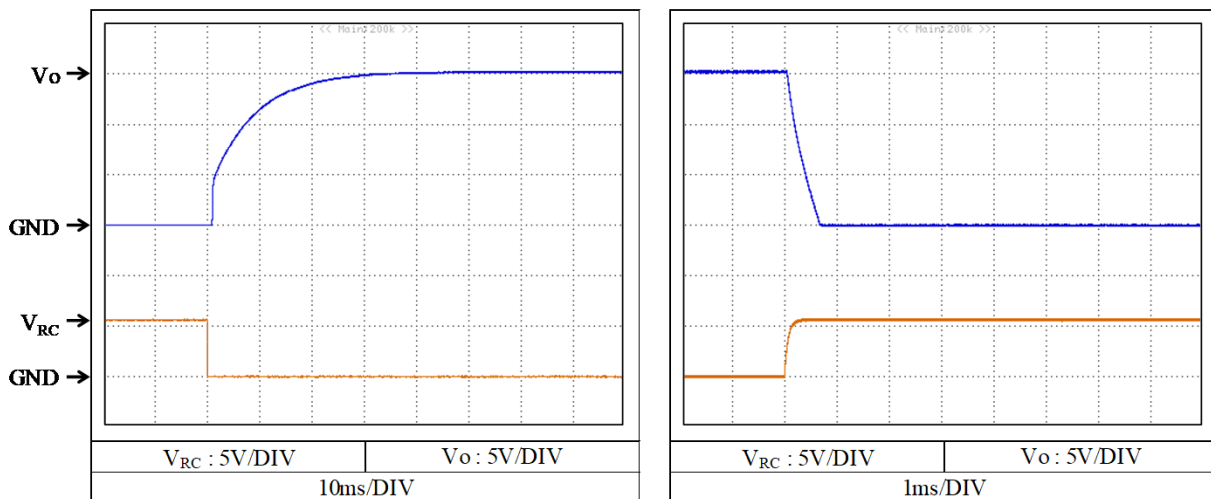

2-6. 過渡応答(負荷急変)特性 Dynamic load response characteristics

Conditions  $V_{in}$  : 24 VDC  
 $T_a$  : 25 °C

3.3V

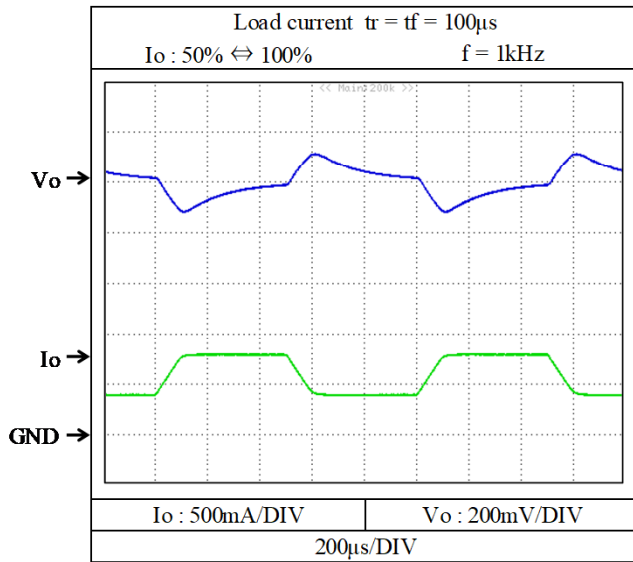

5V

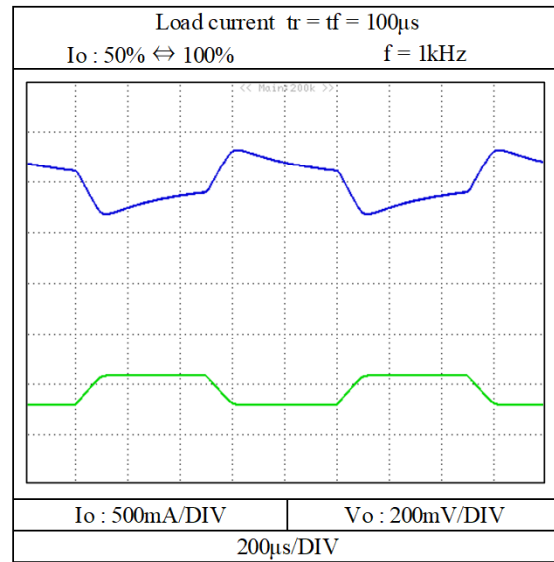

12V

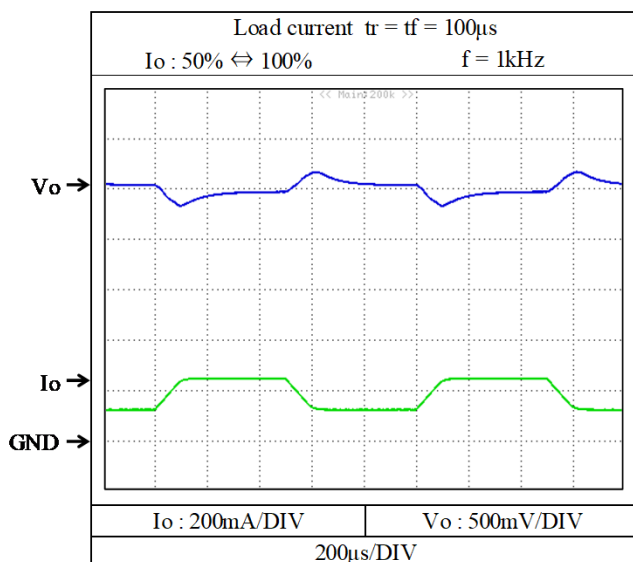

15V

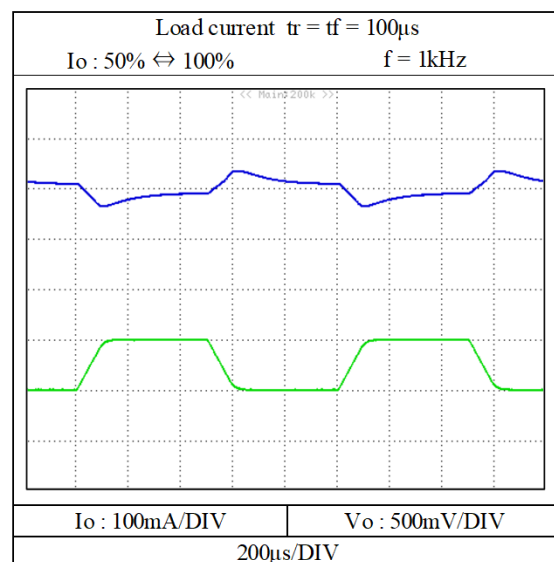

2-7. 入力サージ電流(突入電流)特性 Inrush current characteristics

Conditions  $V_{in}$  : 24 VDC  
 $I_o$  : 100 %  
 $T_a$  : 25 °C

5V

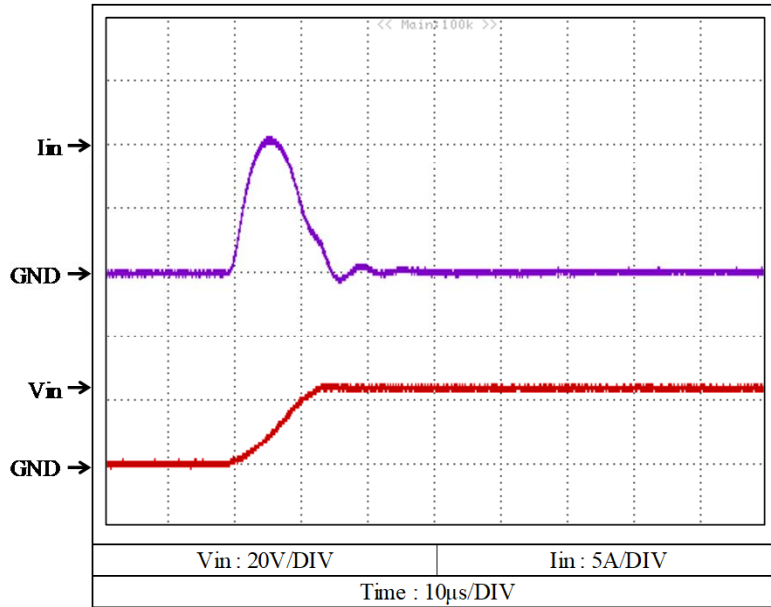

CCG3-24-xxSの入力サージ電流特性は CCG3-24-05S と同等です。  
 CCG3-24-xxS have the same Inrush current characteristics as CCG3-24-05S data.

2-8. 出力リップルノイズ波形 Output ripple and noise waveform

Conditions  $V_{in}$  : 24 VDC  
 $I_o$  : 100 %  
 $T_a$  : 25 °C

3.3V

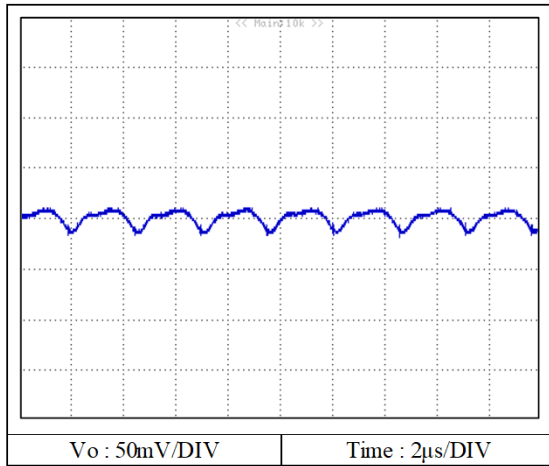

5V

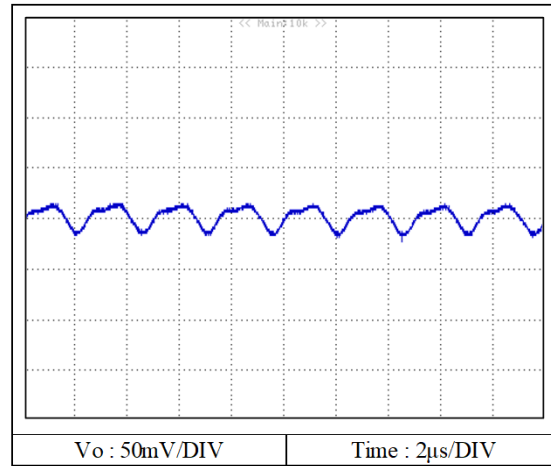

12V

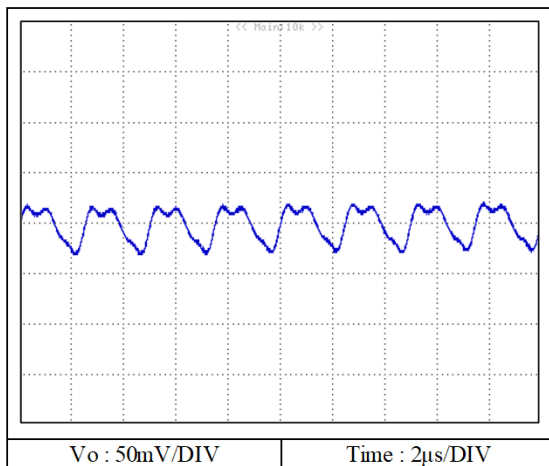

15V

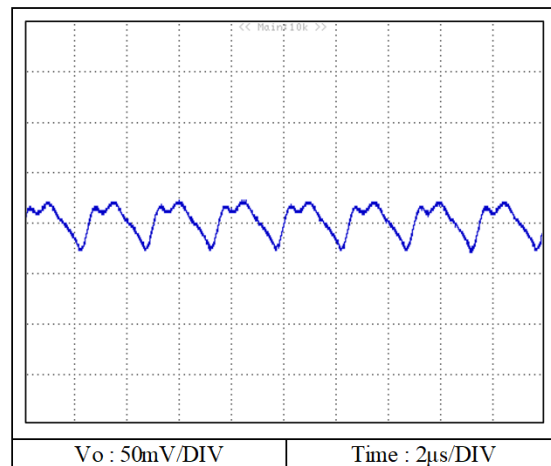

2-9. EMI特性 Electro-Magnetic Interference characteristics

(a) 雑音端子電圧 (帰還ノイズ) Conducted Emission Noise

Conditions Vin : 24 VDC  
 Io : 100 %  
 Ta : 25 °C

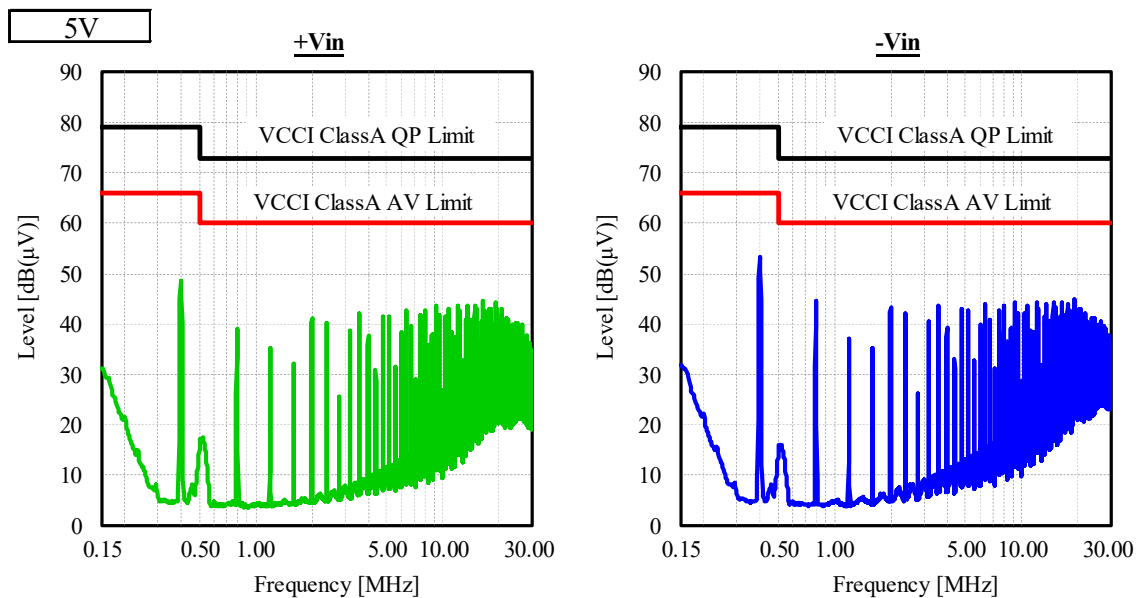
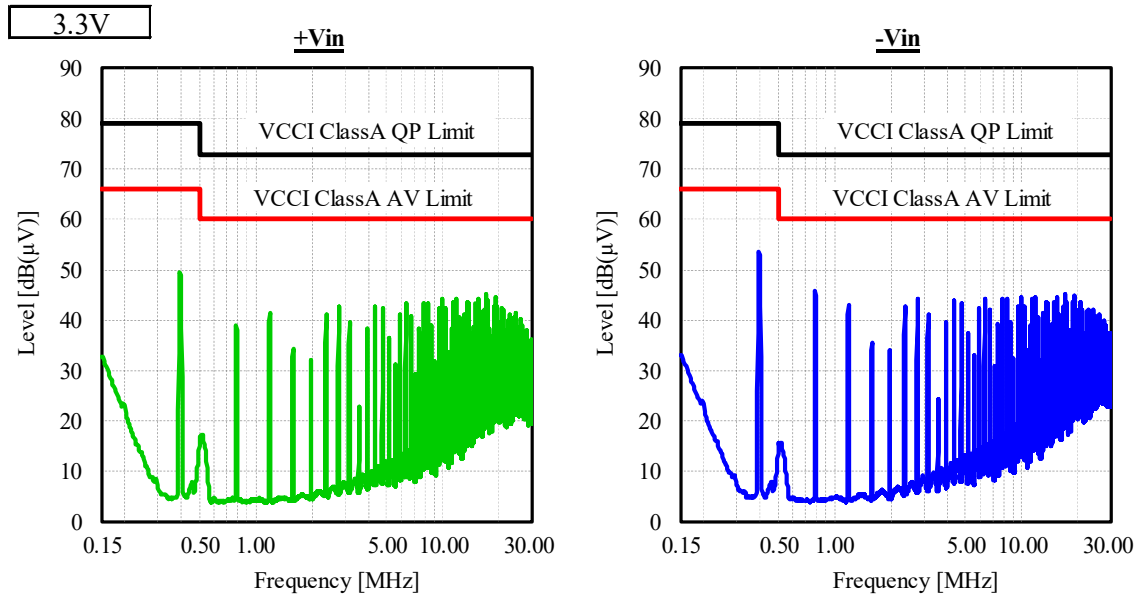

表示はQP値  
 Indication is QP values.



2-9. EMI特性 Electro-Magnetic Interference characteristics

(a) 雑音端子電圧 (帰還ノイズ) Conducted Emission Noise

Conditions Vin : 24 VDC  
Io : 100 %  
Ta : 25 °C

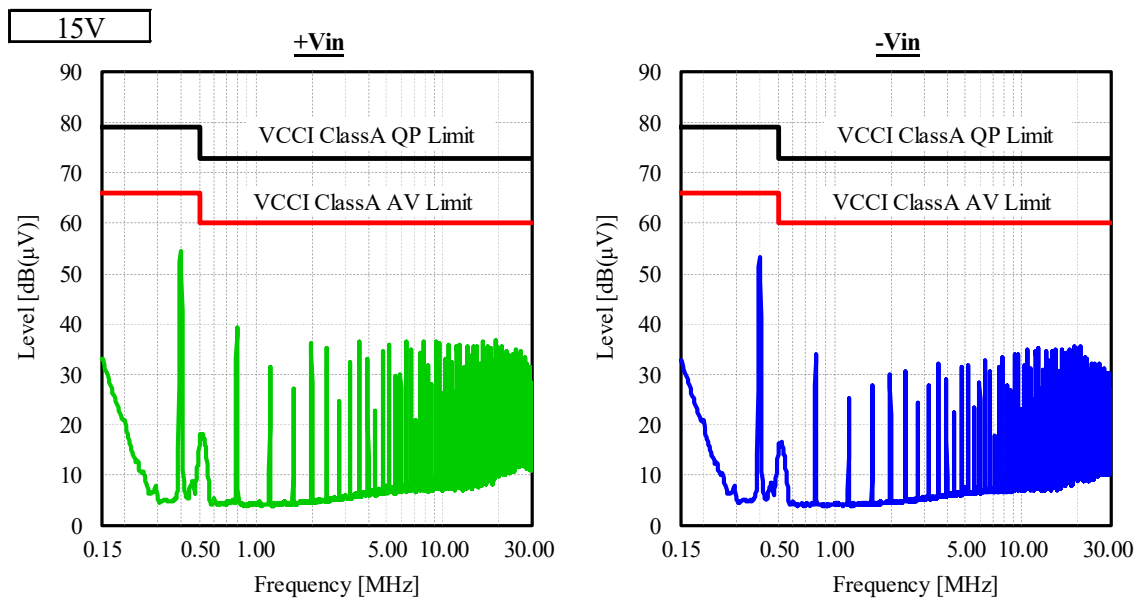
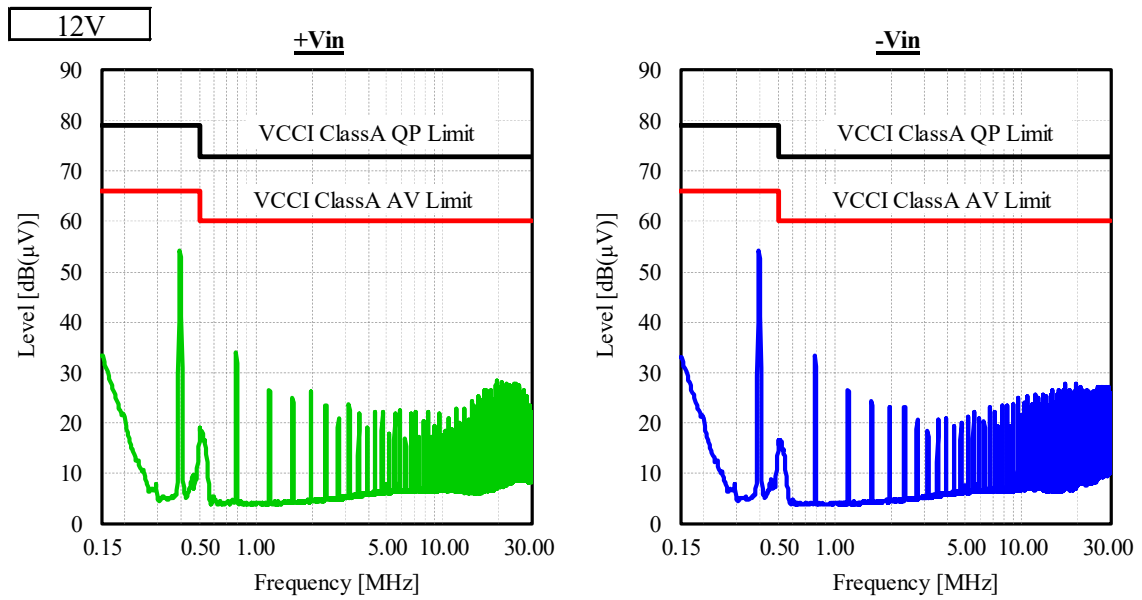

表示はQP値  
Indication is QP values.

2-9. EMI特性 Electro-Magnetic Interference characteristics  
 (b) 雑音電界強度 (輻射ノイズ) Radiated Emission Noise

Conditions Vin : 24 VDC  
 Io : 100 %  
 Ta : 25 °C

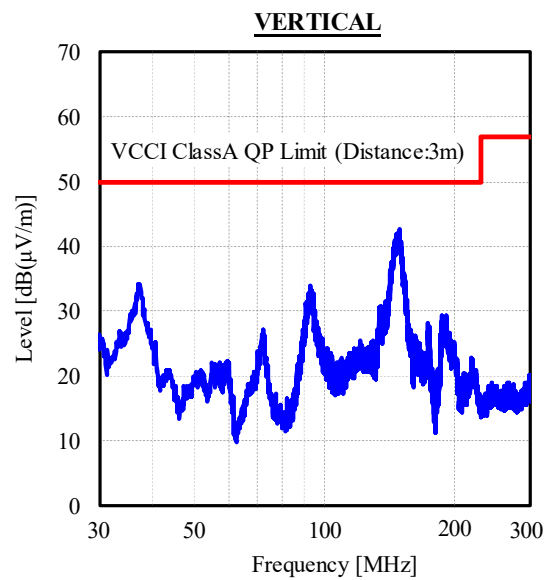
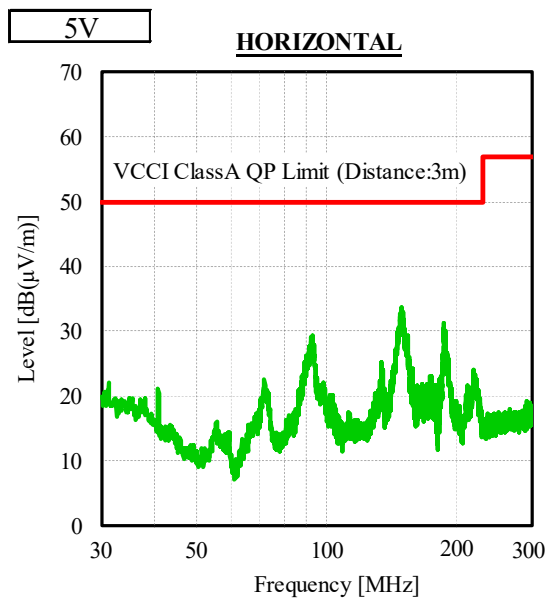
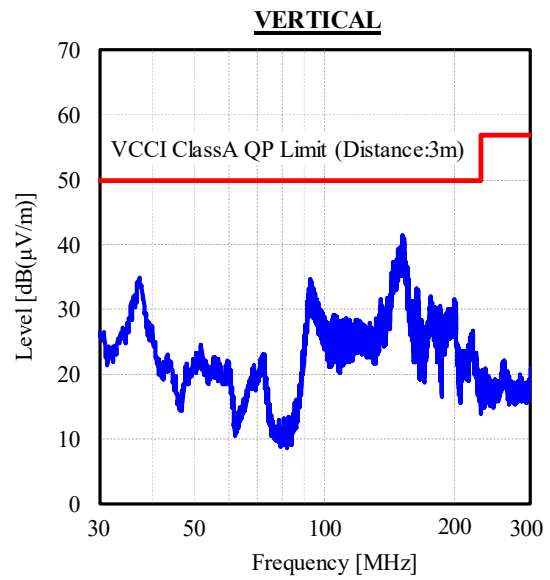
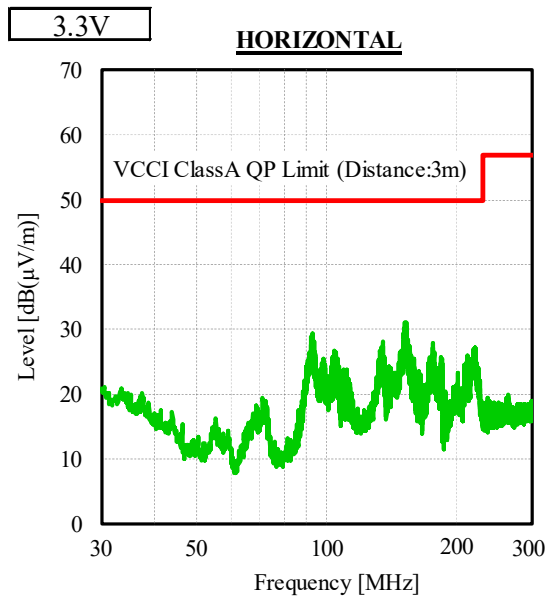

表示はピーク値  
 Indication is peak values.

2-9. EMI特性 Electro-Magnetic Interference characteristics  
 (b) 雑音電界強度 (輻射ノイズ) Radiated Emission Noise

Conditions Vin : 24 VDC  
 Io : 100 %  
 Ta : 25 °C

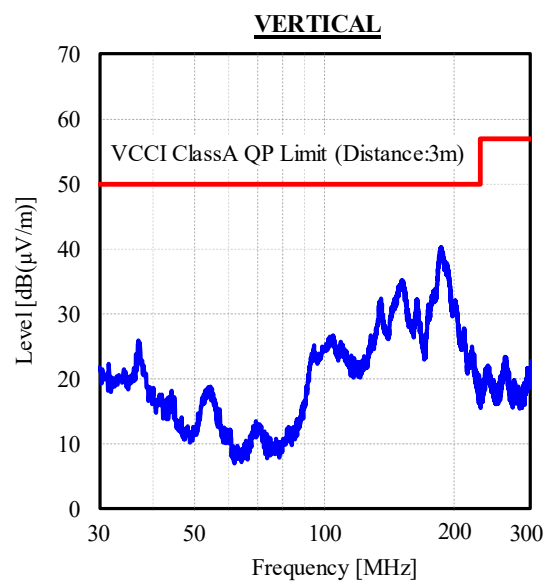
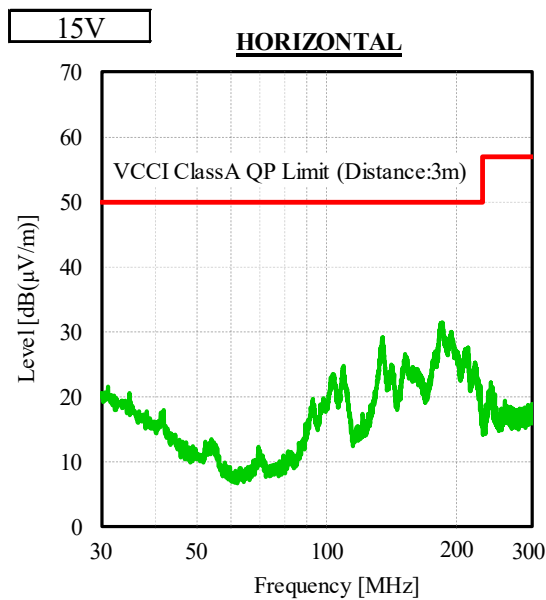
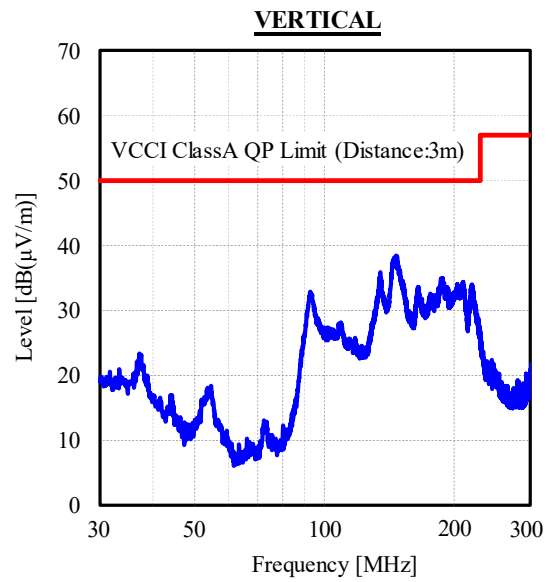
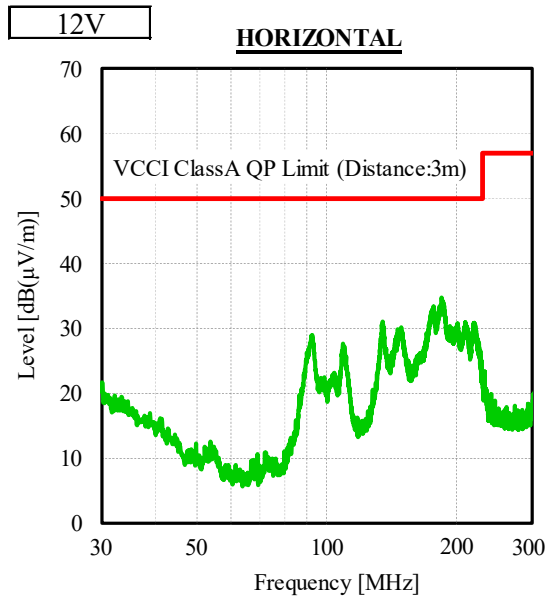

表示はピーク値  
 Indication is peak values.