

CN200,300B110 Series

Instruction Manual

BEFORE USING THE POWER SUPPLY UNIT

Be sure to read this instruction manual thoroughly before using this product. Pay attention to all cautions and warnings before using this product. Incorrect usage could lead to an electrical shock, damage to the unit or a fire hazard.

⚠ DANGER

- Never use this product in locations where flammable gas or ignitable substances are present.

⚠ INSTALLATION WARNING

- When installing, ensure that work is done in accordance with the instruction manual. When installation is improper, there is risk of electric shock and fire.
- Installation shall be done by Service personnel with necessary and appropriate technical training and experience. There is a risk of electric shock and fire.
- Do not cover the product with cloth or paper etc. Do not place anything flammable around. This might cause damage, electric shock or fire.

⚠ WARNING on USE

- Do not touch this product or its internal components while circuit in operation, or shortly after shutdown. You may receive a burn.
- While this product is operating, keep your hands and face away from it as you may be injured by an unexpected situation.
- There are cases where high voltage charge remains inside the product. Therefore, do not touch even if they are not in operation as you might get injured due to high voltage and high temperature. You might also get electric shock or burn.
- Do not make unauthorized changes to this product nor remove the cover as you might get an electric shock or might damage the product. We will not be held responsible after the product has been modified, changed or disassembled.
- Do not use this product under unusual condition such as emission of smoke or abnormal smell and sound etc. Please stop using it immediately and shut off the product. It might lead to fire and electric shock. In such cases, please contact us. Do not attempt repair by yourself, as it is dangerous for the user.
- Do not operate and store these products in environments where condensation occurs due to moisture and humidity. It might lead fire and electric shock.
- Do not drop or apply shock to this product. It might cause failure. Do not operate these products mechanical stress is applied.

⚠ CAUTION on MOUNTING

- Confirm connections to input terminals, output terminals and signal terminals are correct as indicated in the instruction manual before switching on.
- Input voltage, Output current, Output power, Base-plate temperature, ambient temperature and ambient humidity should be kept within specifications, otherwise the product will be damaged or malfunctioned.
- Input line and output line, please use the wires as short and thick as possible.
- Do not use this product in special environment with strong electromagnetic field, corrosive gas or conductive substances and direct sunlight, or places where product is exposed to water or rain.
- Mount this product properly in accordance with the instruction manual, mounting direction and shall be properly be ventilated.
- Please shut down the input when connecting input and output of the product.
- When mounted in environments where there is conductive foreign matter, dust or liquid, there is possibility of product failure or malfunction. Such as install filter, please consider that a conductive foreign matter, dust and liquid do not invade inside the power supply.

CAUTION on USE

- Product individual notes are shown in the instruction manual. If there is any difference with common notes, individual notes shall have priority.
- Before using this product, be sure to read the catalog and instruction manual. There is risk of electric shock or damage to the product or fire due to improper use.
- Input voltage, Output current, Output power, Base-plate temperature, ambient temperature and ambient humidity should be kept within specifications, otherwise the product will be damaged or malfunctioned, or cause electric shock or fire.
- For products without built-in protection circuit (element, fuse, etc.), insert fuse at the input to prevent smoke, fire during abnormal operation.
- For externally mounted fuse do not use other fuses aside from our specified and recommended fuse.
- As our product is standard industrial use product that was manufactured by purpose that is used to an general electronics equipment etc., it is not products that to designed for High Safety uses (Uses extremely high reliability and safety are required, if reliability and safety has not been secured, with significant dangerousness for directly life or body) is expected. Please consider a fail safe (systems that was provided with protection circuit protective devices or systems that redundant circuit was mounted so that was not unstable in single failure) design enough.
- When used in environments with strong electromagnetic field, there is possibility of product damage due to malfunction.
- When used in environment with corrosive gas (hydrogen sulfide, sulfur dioxide, etc.), there is possibility that they might penetrate the product and lead to failure.
- When used in environments where there is conductive foreign matter, dust or liquid, there is possibility of product failure or malfunction.
- Do not operate and store this product in an environment where condensation might occur. In such case, waterproof treatment is necessary.
- Provide countermeasure for prevention of lightning surge voltage as there is risk of damage due to abnormal voltage.
- Connect together the frame ground terminal of the product and the ground terminal of the equipment for safety and noise reduction. If these ground is not connected together, there is risk of electric shock.
- Take care not to apply external abnormal voltage to the output terminals and signal terminals. Especially, applying reverse voltage or overvoltage more than the rated voltage to the output might cause failure, electric shock or fire.
- Do not use this product in special environment with strong electromagnetic field, corrosive gas or conductive substances and direct sunlight, or places where product is exposed to water or rain.
- Never operate the product under overcurrent or short circuit condition. Insulation failure, or other damages may occur.
- The output of this product may exceed ES1 voltage limits under fault conditions. Therefore the output must be protected in the end equipment to maintain ES1.
- The application circuits and their parameters are for reference only. Be sure to verify effectiveness of these circuits and their parameters before finalizing the circuit design. Moreover, we will not be responsible on application patent or utility model.

Note

- Consider storage of the product at normal temperature and humidity avoiding direct exposure to sunlight at environment with minimal temperature and humidity changes. Storage of product at high temperature, high humidity and environments with severe changes in temperature and humidity might cause deterioration, and occurrence of condensation in the product.
- When disposing product, follow disposal laws of each municipality.
- The information in this document is subject to change without prior notice. Please refer to the latest version of the data sheet, etc., for the most up-to date specifications of the product.
- No part of this document may be copied or reproduced in any form without prior written consent TDK-Lambda.

⚠ LONG-TERM STORAGE METHOD AND LONG-TERM STORAGE PERIOD

- Please keep the product in carton box..
- Please do not apply excessive vibration, shock or mechanical stress applied directly to the product.
- Please keep away from direct sunlight.
- For long-term storage temperature and humidity, the following conditions shall be used as a guideline :
 - Temperature range : 5°C~30°C
 - Humidity range : 40%~60%RH
 - Please keep away from the places where temperature and humidity can change drastically.
 - It can cause condensation on the product or deterioration.
- For long-term storage period, we recommend to use within 2 years after receiving the product.
 - For products that have been received for more than 1 year, please check lead oxidation and solderability.
 - In addition, SMD type products may have MSL (Moisture Sensitivity Level) provision.
 - Please be sure to read the instruction manual and delivery specifications.

1. Model Name Identification Method

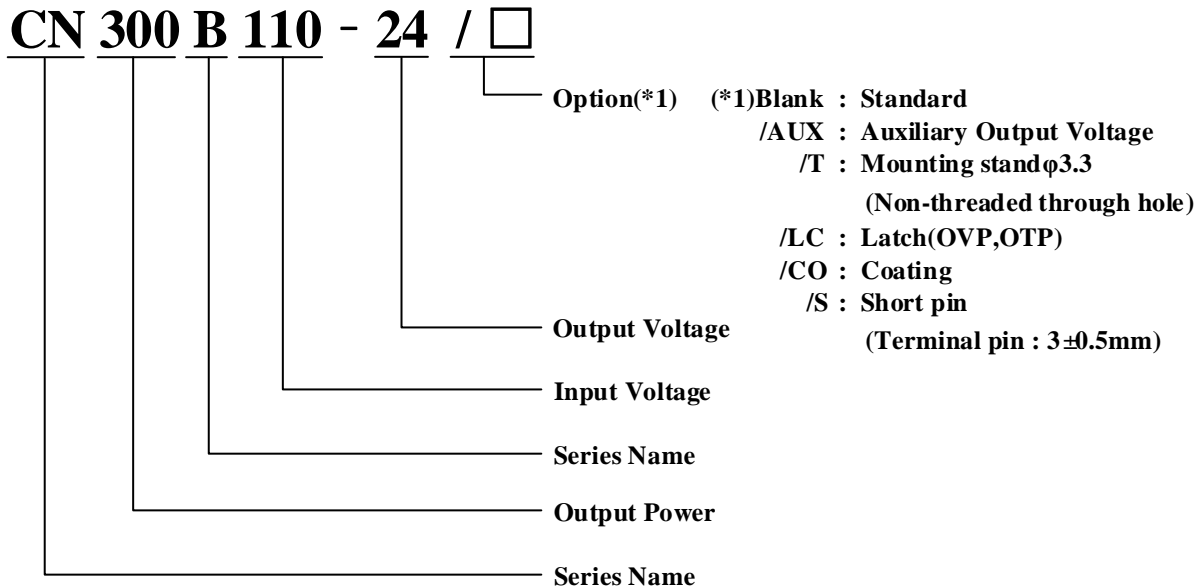

2. Products Line Up

	Model Name	Output Power	Output Voltage	Output Current
CN300B110	CN300B110-12	300.0W	12V	25.0A
	CN300B110-13.8	299.5W	13.8V	21.7A
	CN300B110-15	300.0W	15V	20.0A
	CN300B110-24	300.0W	24V	12.5A
CN200B110	CN200B110-12	200.4W	12V	16.7A
	CN200B110-13.8	200.1W	13.8V	14.5A
	CN200B110-15	201.0W	15V	13.4A
	CN200B110-24	201.6W	24V	8.4A

The board coating specification(/CO model):

The CN200,300B110 series consists of an aluminum board and a control board.

The coating application range of /CO model can be confirmed through the below table.

Model	Aluminum board		Control board
	Resin-molded	Coating	Coating
CN300B110-*/*	Yes	-	-
CN300B110-*/CO*	Yes	-	Yes
CN200B110-*/*	-	-	-
CN200B110-*/CO*	-	Yes	Yes

3. Terminal Explanation

CN200,300B110

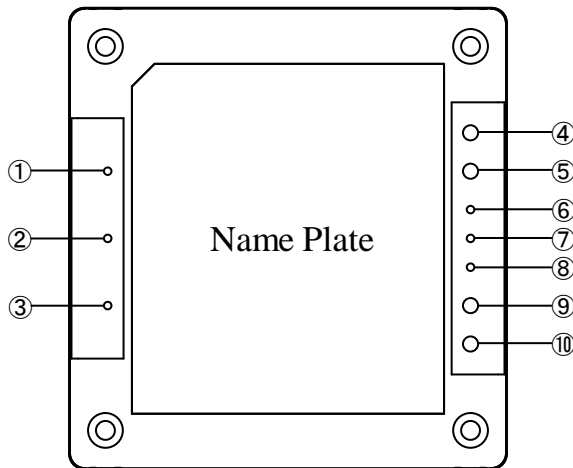

- ① CNT : ON/OFF Control Terminal
- ② -Vin : -Input Terminal
- ③ +Vin : +Input Terminal
- ④ -V : -Output Terminal
- ⑤ -S : -Remote Sensing Terminal
- ⑥ IOG : Inverter Operation Good Terminal
AUX : Auxiliary Output Voltage Terminal
for /AUX Sub-Model
- ⑦ TRM : Output Voltage Trimming Terminal
- ⑧ PC : Output Current Balance Terminal
- ⑨ +S : +Remote Sensing Terminal
- ⑩ +V : +Output Terminal

- Base-plate can be connected to FG (Frame Ground) by M3 threaded holes.
- Connect +Vin, -Vin, +V, -V with consideration of contact resistance.

4. Block Diagram

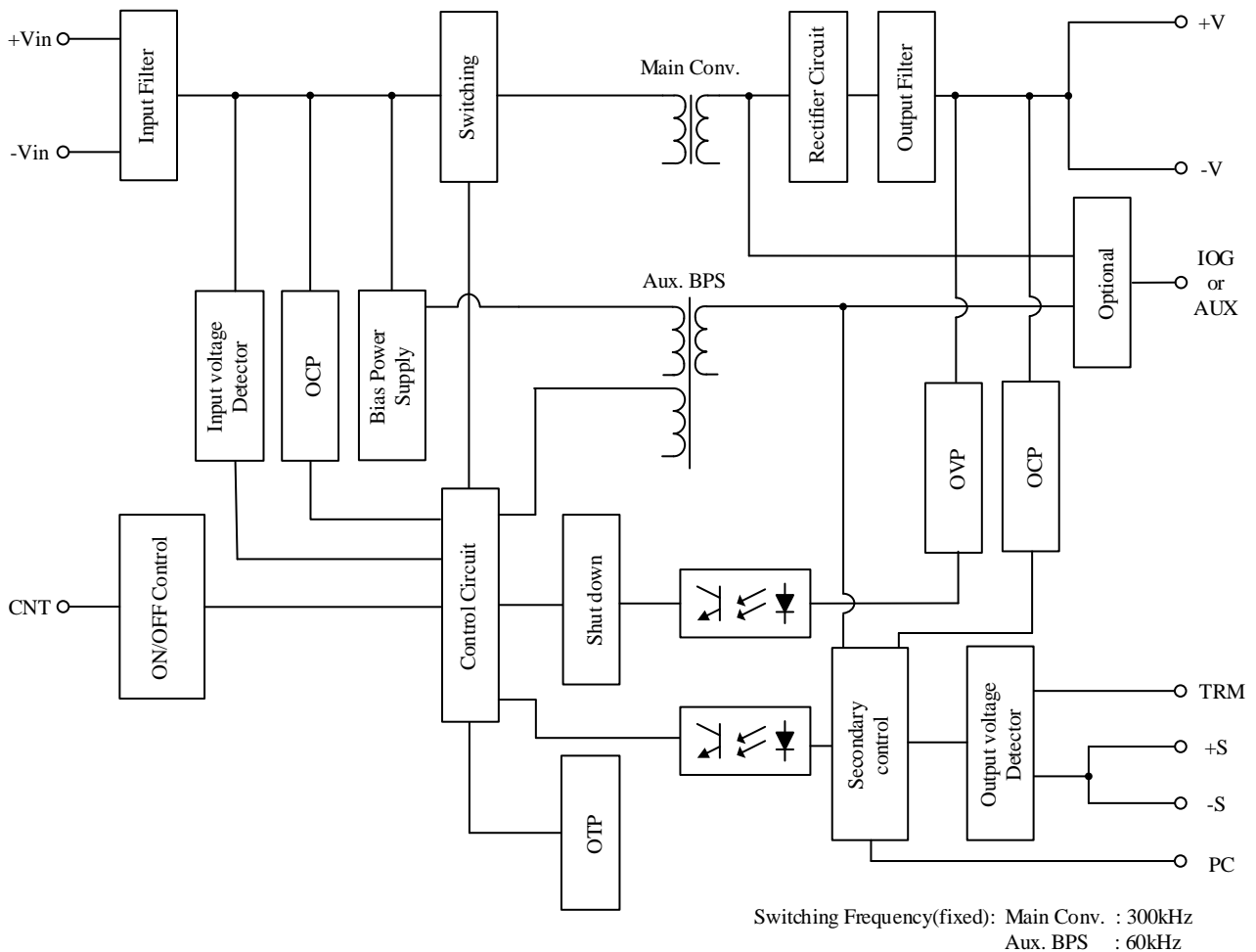

5. Sequence Time Chart

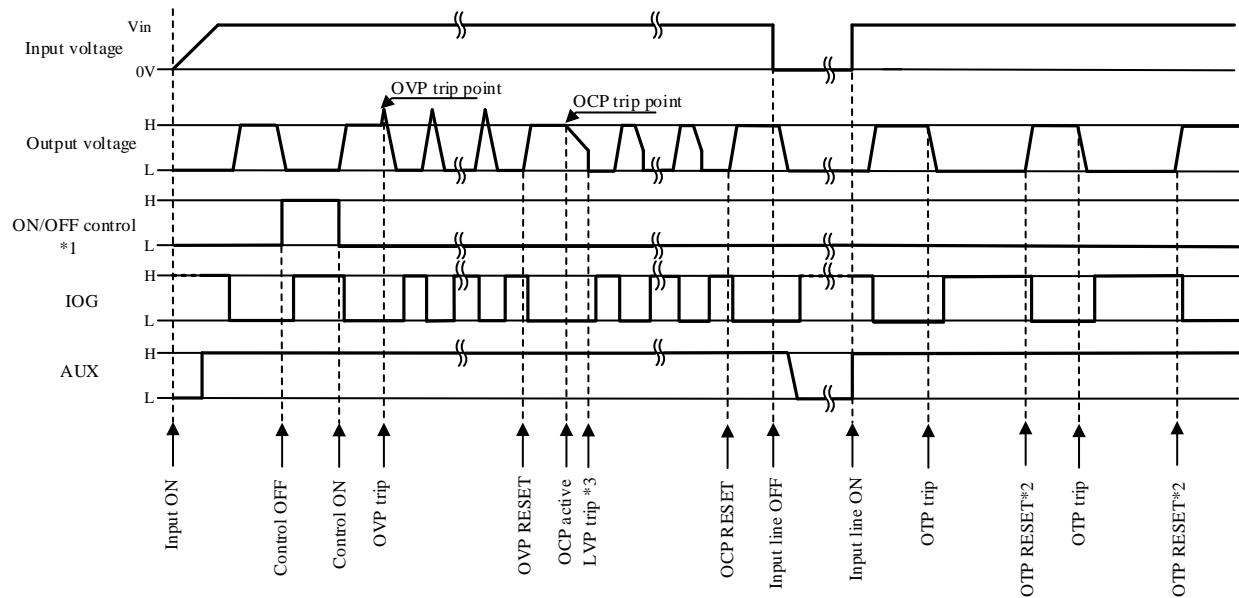

- *1 Level: $4V \leq H \leq 30V$ or Open, $0V \leq L \leq 0.8V$ or short.
- *2 OTP reset when Tbp is lower than $100^{\circ}C$.
- *3 LVP: Low Voltage Protection

6. Terminal Connecting Method

In order to use the CN200,300B110 Series, this module must be connected with external components according to Fig.6-1.

Pay attention to the each wiring. If it is connected to wrong terminal, the power supply will be damaged. CN200,300B110 series employs conduction cooling method. Use heat sink and fan to dissipate heat. For selection of heat sink and heat sink dissipation method, refer to the Power Module Application Note. External noise filter should be connected in order to meet EMI, EMS requirement. Refer to Evaluation data, Reliability data and IEC61000 Test data of CN200,300B110 series.

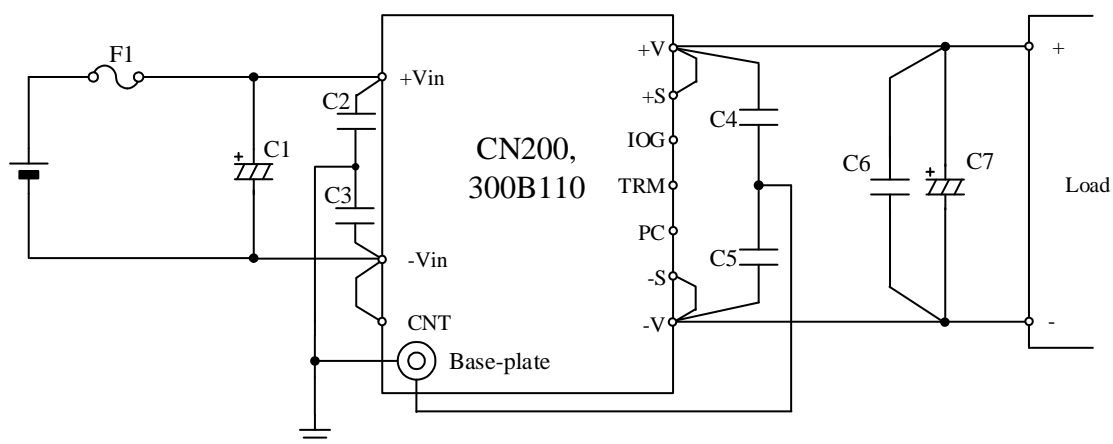

Fig.6-1 Basic connection

F1 : Input Fuse

The CN200,300B110 Series has no built-in fuse.

Use external fuse to acquire various Safety Standards and to improve safety. Moreover, use fast-blow type for every power supply.

Furthermore, fuse must be connected to the +Vin side if -Vin side is used as ground, or fuse must be connected to -Vin side if +Vin side is used as a ground.

Input Fuse Recommended Current Rating :

CN200,300B110: 20A or lower

Consider margin over the actual input voltage to be used when selecting fuse.

Moreover, consider I^2t fuse rating for surge current (inrush current) during line throw-in.

C1:

To prevent the effect of input line inductance to the power supply, connect electrolytic capacitor between +Vin and -Vin terminals.

Take note that in case of large equivalent series resistance (especially operation at low ambient temperature), power supply output might not shut down normally.

Recommended Capacitor Value: 220 μ F or more

Moreover, consider to keep margin over the actual input voltage to be used when selecting electrolytic capacitor.

- Note)
1. Use low impedance electrolytic capacitor with excellent temperature characteristics.
(Nippon Chemi-con KXJ Series or equivalent)
 2. Use more than two recommended capacitor above in parallel when ambient temperature becomes lower than -20°C to reduce ESR.
 3. When input line inductance becomes excessively high due to insertion of choke coil, operation of the power supply could become unstable. For this case, increase C1 value more than the value indicated above.
 4. The module might be damaged by occurrence of surge which is several times the input voltage due to input line inductance during turn on. Therefore, add electrolytic capacitor at Input terminal and so on to absorb surge.
Moreover, if slope of input voltage is steep, add electrolytic capacitor so that dv/dt of rise up slope become less than below.

CN200,300B110 : $dv/dt = 10\text{V}/\mu\text{s}$ or lower

C2,C3:

For stable operation of the power supply, add recommended capacitance or more with high voltage rating. C2 is connected between +Vin terminal and base-plate, C3 is connected between -Vin terminal and base-plate, as close as possible to the each terminals. However, select capacitance taking into consideration chapter 7-22. Withstand Voltage "Withstand Voltage including external components." Moreover, take note that stable operation might not be attained due to wiring method of PCB, etc. In such case, countermeasure is possible by increasing C2 and C3 capacitance value or adding common mode choke coil before C1. Addition of common mode choke coil is recommended to improve EMI. When using multiple power supplies, add choke to each power supply input. High withstand voltage are applied across this capacitor depending on the application. Select capacitor with high withstand voltage rating.

Table.6-1 C2,C3 : Recommended Values of External Input Capacitor

Model	C2	C3
CN200,300B110	4700pF or more	4700pF or more

C4,C5:

Connect ceramic or film capacitor as EMI/EMS countermeasure and to reduce spike noise. High withstand voltage is applied across this capacitor during withstand voltage test depending on the application. Connect C4 as close as possible to +V terminal, C5 as close as possible to -V terminal.

Table.6-2 C4,C5 : Recommended Values of External Output Capacitor

Model	C4	C5
CN200,300B110	0.022uF or more	0.022uF or more

C6 :

Add ceramic capacitor in order to reduce output spike noise voltage. (Recommended : 10μF)
 Take note that, PCB wiring design might influence output spike noise.

C7:

For stable operation, connect a electrolytic capacitor between +V and -V.
 Take note that output ripple could be affected by electrolytic capacitor, equivalent impedance and inductance characteristics of wiring.
 For cases of abrupt changes in load current or input voltage, increasing capacitance value of the external capacitors could reduce the voltage fluctuation.
 Model and C7 recommended values of external output capacitor are below.

Table.6-3 C7 : Recommended Values of External Output Capacitor (CN200,300B110)

Output Voltage	C7
12V	25V 1000 μ F
13.8V	25V 1000 μ F
15V	25V 1000 μ F
24V	50V 470 μ F

- Note)
1. Use low impedance electrolytic capacitor with excellent temperature characteristics. (Nippon Chemi-Con LXY Series or equivalent)
 2. Use more than three recommended capacitor above in parallel when ambient temperature becomes lower than -20°C to reduce ESR.
 3. Take note of the allowable ripple current of the capacitor to be used. Especially, for sudden load current change, verify actual ripple current and make sure that allowable maximum ripple current is not be exceeded.
 4. The maximum capacitance value is 30,000 μ F. When adding more capacitance than this, please fully check the operation with the actual application.

• Reverse Input Connection

Reverse input polarity would cause power supply damage. For cases where reverse connections are possible, connect a protective diode and fuse. Use protective diode with higher voltage rating than the input voltage, and with higher surge current rating than the fuse current rating.

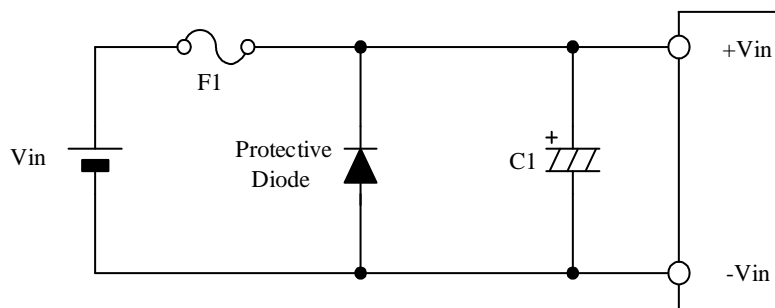

Fig.6-2 Protection for Reversed Connection of Input

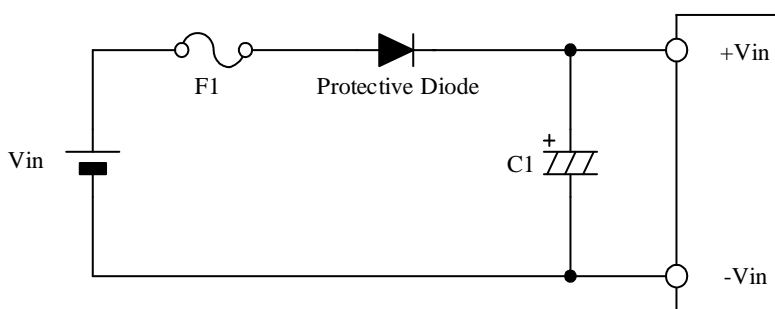

Fig.6-3 Series Connected Input Diode Application

7. Explanation of Functions and Precautions

7-1. Input Voltage Range

Input voltage range for the CN200,300B110 Series is indicated below.

Input Voltage Range : 43 - 160VDC

Ripple voltage (V_{rpl}) which results from rectification and filtering of commercial AC line is might be included within the input voltage as shown in Fig. 7-1.

In this case, ripple voltage must be limited within the voltage described below.

Allowable Input Ripple Voltage: 10Vp-p

When this value is exceeded, the output ripple voltage becomes large.

Take note that sudden input voltage change might cause variation of output voltage transitionally.

Moreover, maximum value and minimum value of input voltage waveform must not go beyond the limit of above input voltage range.

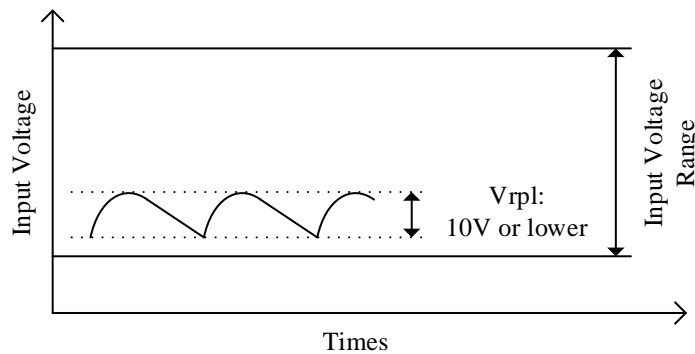

Fig.7-1 Input Ripple Voltage

7-2. Output Voltage Adjustment Range

Output voltage could be adjusted within the range described below by external resistor or variable resistor.

Output Voltage Adjustment Range

CN200,300B110

12V,15V: -20% - +20% of Nominal Output Voltage

13.8V: -30% - +4% of Nominal Output Voltage

24V: -20% - +10% of Nominal Output Voltage

- Note) 1. When increasing the output voltage, reduce the output current accordingly so as not to exceed the maximum output power.
2. When output voltage is decreased, maximum output current is until rated maximum output current of specifications.
3. Take note that PCB wiring of TRM is not long when TRM function is used.
4. PCB wiring or position of output capacitor might influence output ripple when output voltage is changed, adding output capacitor near output terminal can reduce output ripple.

Remote sensing is possible even when output voltage is varied. For details on remote sensing function, please refer to "7-10. Remote Sensing".

For CN200,300B110, take note that when output voltage is increased, input voltage range is limited as shown in Fig.7-2.

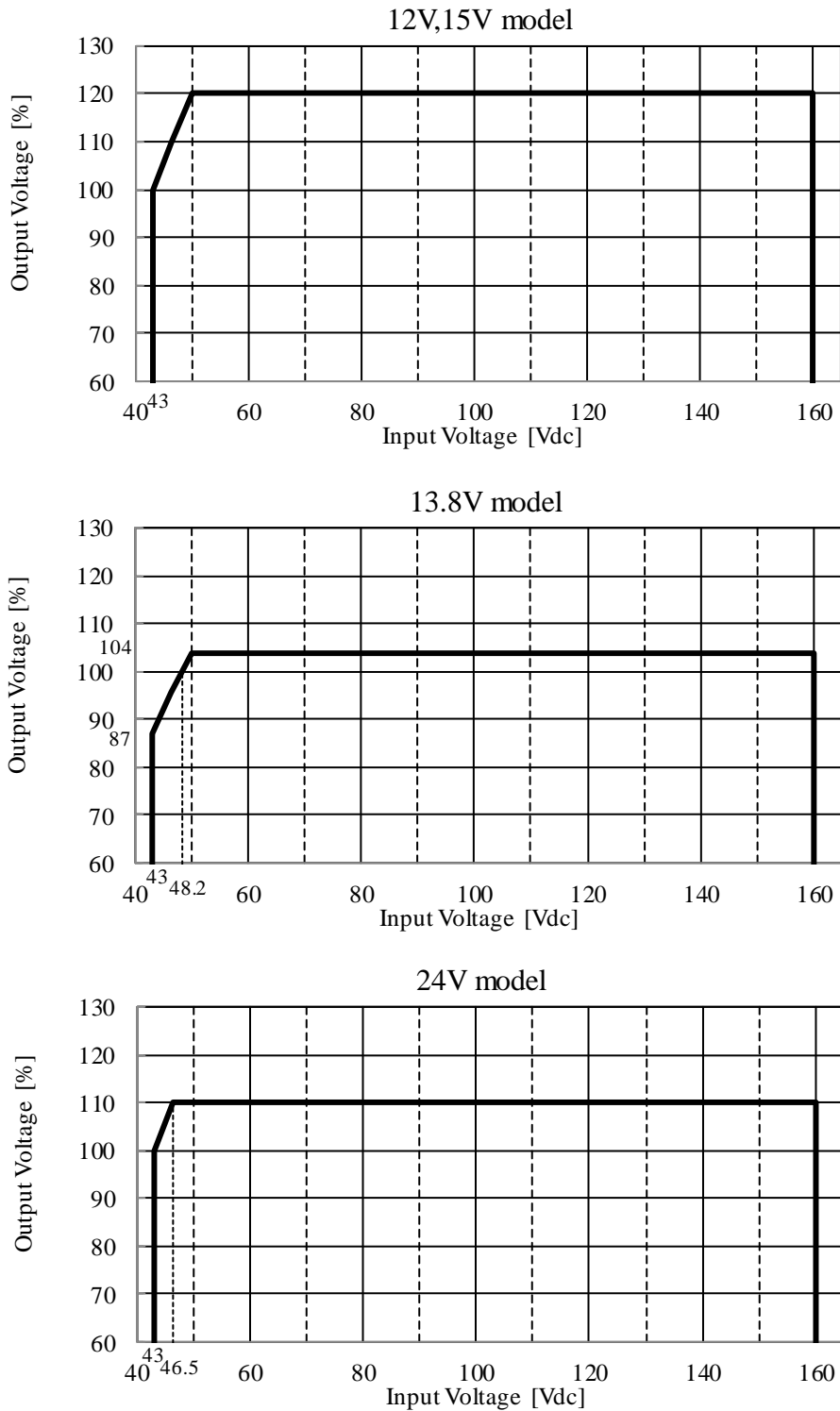

Fig.7-2 Limit of Input voltage

● **Output Voltage Adjustment by External Resistor ,Variable Resistor or Applying External Voltage.**

(1) In case of adjusting output voltage lower (CN200,300B110)

(1-1) Maximum output current

Allowable maximum output current = rated maximum output current of specification.

(1-2) External resistor connecting method

Connect an external resistor Radj(down) between the TRM terminal and -S terminal.

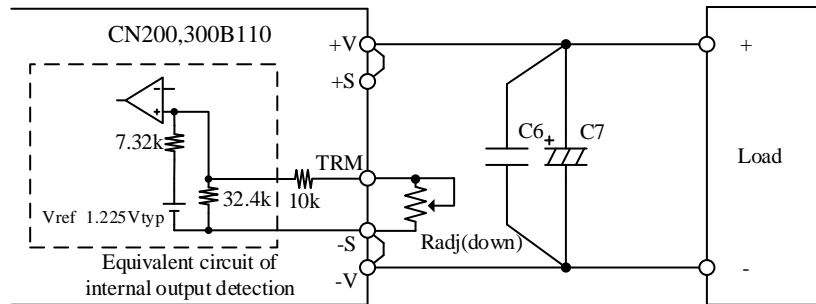

Fig.7-3 Connection for Output Voltage Trim Down

(1-3) Equation of external resistor and output voltage

$$\text{Radj}(\text{down}) = 5.971 \times \frac{(1 - \Delta(\%)/100)}{\Delta(\%)/100} - 10 \quad [\text{k}\Omega]$$

Radj(down) : External adjustment resistor

$\Delta(\%)$: Output voltage change rate against nominal output voltage

ex) When setting 12V Model to 10.8V output (-10%), $\Delta(\%)$ should be set at 10.

Below graph is relation $\Delta(\%)$ and value of external resistor.

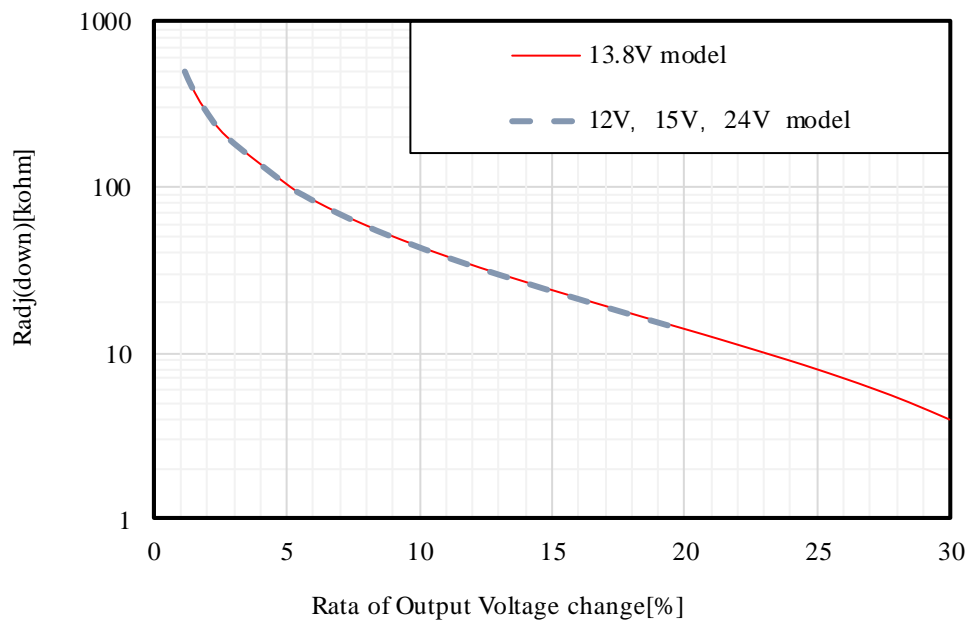

Fig.7-4 Radj(down) vs. $\Delta(\%)$

(2) In case of adjusting output voltage higher (CN200,300B110)

(2-1) Maximum output current

Allowable maximum output current = maximum output power ÷ adjusting output voltage.

(Becomes less than maximum output current of specification.)

(2-2) External resistor connecting method

Connect an external resistor Radj(up) between +V terminal and +S terminal.

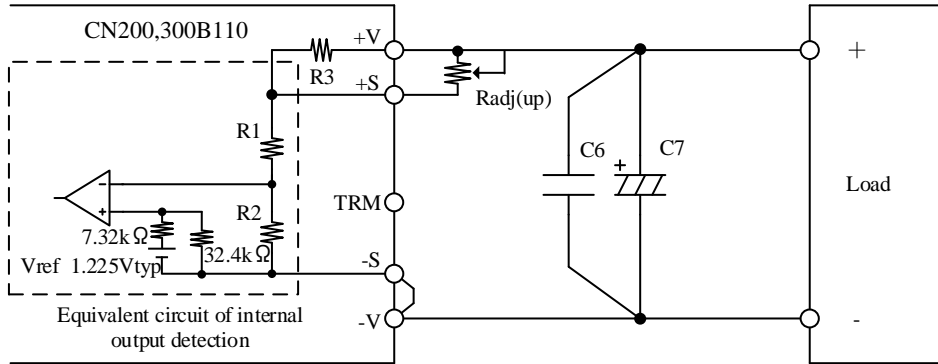

Fig.7-5 Connection for Output Voltage Trim Up

(2-3) Equation of external resistor and output voltage

$$\text{Radj(up)} = \frac{(R1 + R2) \times \Delta(\%)}{100} \quad [\text{k}\Omega] \quad (12\text{V}, 13.8\text{V}, 15\text{V model})$$

$$\text{Radj(up)} = \frac{R3 \times (R1 + R2) \times \Delta(\%)}{100 \times R3 - (R1 + R2) \times \Delta(\%)} \quad [\text{k}\Omega] \quad (24\text{V model})$$

Radj(up) : External adjustment resistor

Δ(%) : Output voltage change rate against nominal output voltage

ex) When setting 12V Model to 13.2V output (+10%), Δ(%) should be set at 10.

R1,R2,R3 : Internal resistor (Please refer to Table 7-2)

Table 7-2 Internal resistor value

Vo	12V	13.8V	15V	24V
R1	11.01kΩ	12.81kΩ	14.01kΩ	23.02kΩ
R2	1kΩ	1kΩ	1kΩ	1kΩ
R3	OPEN	OPEN	OPEN	6.8kΩ

Below graph is relation Δ(%) and value of external resistor.

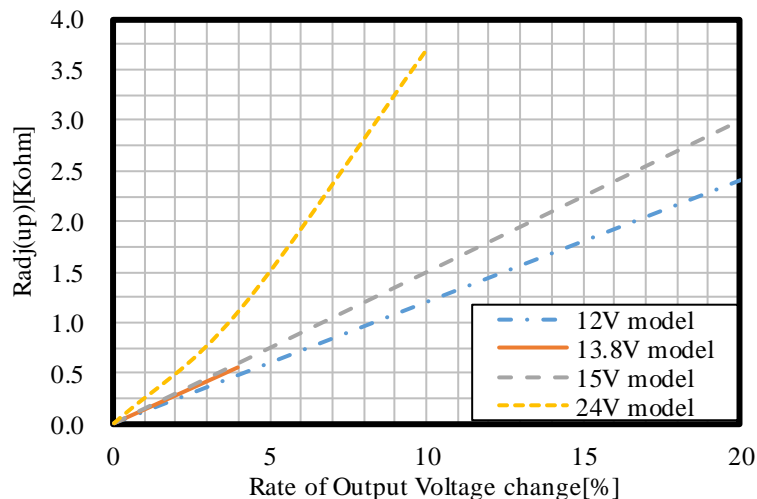

Fig.7-6 Radj(up) vs. Δ(%)

(3) To adjust output voltage for whole range. (CN200,300B110)

(3-1) Maximum output current

In case of adjusting output voltage lower

Allowable maximum output current = rated maximum output current of specification.

In case of adjusting output voltage higher

Allowable maximum output current = maximum output power ÷ adjusting output voltage.

(Becomes less than maximum output current of specification.)

(3-2) External resistor connecting method

For CN200,300B110, external resistance (Rex) is connected between TRM terminal and -S terminal, and variable resistor (VR) is connected between +S terminal and +V terminal.

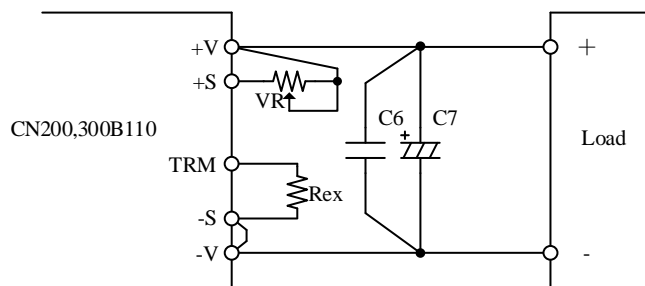

Fig.7-7 Example of Connecting External Resistor (To adjust output voltage for whole range)

(3-3) External resistor and External variable resistor

Output voltage can be adjusted within specifications of output voltage adjustment range if resistance values of external resistor (Rex) and external variable resistor (VR) as follows are connected like a Fig. 7-7. Take note that output voltage do not become out of specifications when output voltage is adjusted.

Table 7-3 Values of External Resistor Rex (CN200,300B110)

Vo	12V	13.8V	15V
Rex	3.3kΩ		

External Resistor(Rex): Tolerance ±5% or less

External Variable resistor (VR): Tolerance ±20% or less, End resistance 1% or less

Note: This method is not suitable for 24V models

Below graph is relation Δ(%) and value of external Variable Resistor (VR) if Rex is connected according to value in above table.

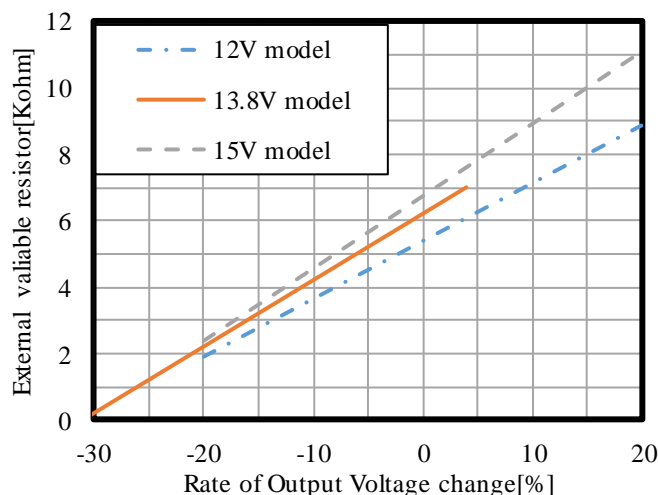

Fig.7-8 External Variable Resistor(VR) vs. Δ(%)

(4) Output Voltage Adjustment by applying external voltage. (CN200,300B110)

(4-1) Maximum output current

In case of adjusting output voltage lower

Allowable maximum output current = rated maximum output current of specification.

In case of adjusting output voltage higher

Allowable maximum output current = maximum output power ÷ adjusting output voltage.

(Becomes less than maximum output current of specification.)

(4-2) External voltage applying method

By applying external voltage at the TRM terminal, output voltage can be adjusted within the same output voltage adjustment range as the output voltage adjustment by external resistor or variable resistor.

For this case, output voltage can be determined by the formula shown below.

$$\text{Output Voltage} = (\text{TRM Terminal Voltage} \times 0.374 + 0.626) \times \text{Nominal Output Voltage}$$

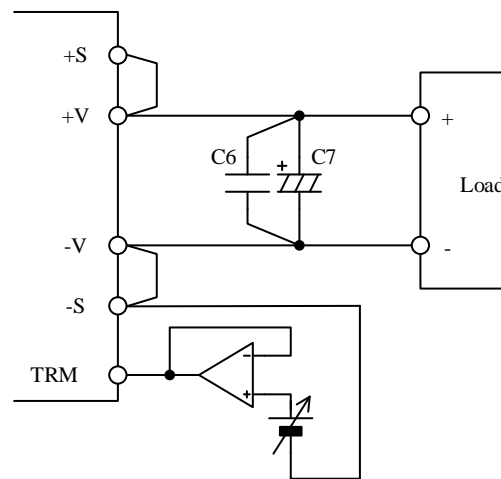

Fig.7-9 Output voltage adjustment by applying external voltage

For applications other than the above, refer to the TRM circuit as shown in Fig.7-10 and determine external circuit and components values.

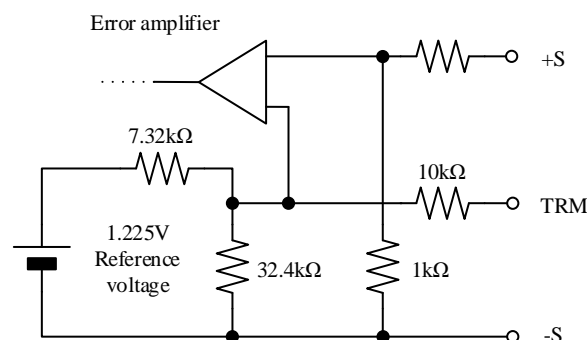

Fig.7-10 Internal TRM circuit (for the reference)

7-3. Maximum Output Ripple and Noise

Measured value according to the specified methods based on JEITA RC-9141B (Clause 7.12 and clause 7.13) which is described in the following .

Connect according to Fig. 7-11 and measure. Connect capacitors (C6 : ceramic capacitor , C7 : electrolytic capacitor) at 50mm distance from the output terminals.

Measure at ceramic capacitor (C6) terminals as shown in Fig. 7-11 using coaxial cable with JEITA attachment.

Use oscilloscope with 100MHz frequency bandwidth or equivalent.

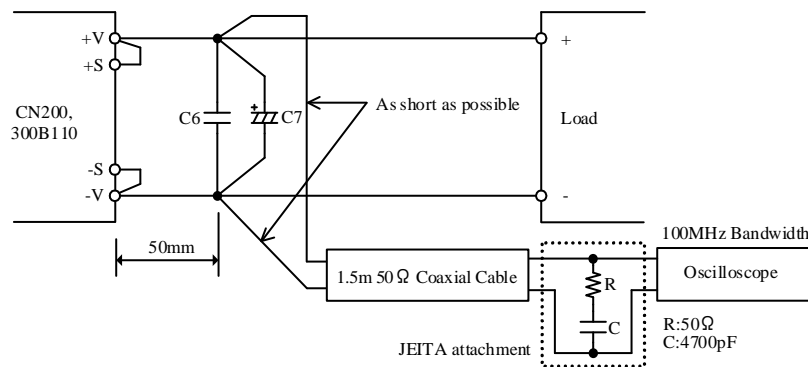

Fig.7-11 Measurement of Maximum Output Ripple and Noise

Take note that, PCB wiring design might influence output spike noise.

Generally, increasing capacitance value of external capacitor can reduce output ripple voltage and output spike noise.

7-4. Maximum Line Regulation

Maximum value of output voltage change when input voltage is gradually varied (steady state) within specified input voltage range.

7-5. Maximum Load Regulation

Maximum value of output voltage change when output current is gradually varied (steady state) within specified output current range.

When using at dynamic load mode, audible noise could be heard from the power module and output voltage fluctuation might increase. A thorough pre-evaluation must be performed before using this power supply.

7-6. Base-plate Temperature vs. Output Voltage Drift

Output voltage drift is defined as the rate of voltage change when only base-plate temperature is changed during operation.

7-7. Output Over Current Protection (OCP)

The power module has built-in OCP function.

During overload conditions, the power module may protect themselves by reducing output voltage to limit power (constant current limit mode). Except "/LC" model, when output voltage is about under 40% by short circuit or overload condition that continue about 0.1s, output will enter a hiccup current limit mode.

For "/LC" module, the power module may protect themselves by reducing output voltage to limit power, however, the power supply will enter the hiccup current limit mode for several cycles and then enter the constant current limit mode when the overload current increases with a large slope or short circuit mode.

OCP setting value is fixed and therefore, cannot be externally adjusted.

Take note that power module might be damaged at continuous output short circuit or over load conditions depending on thermal conditions.

7-8. Output Over Voltage Protection (OVP)

This power module has built-in OVP function.

OVP set point is relative to the rated output voltage value. When output voltage exceed OVP set point, output voltage shut down. OVP setting value is fixed and therefore, cannot be externally adjusted.

When OVP is triggered, can be auto recovery.

For the "/LC" model, cannot recover automatically. Recycle output either by, recycling the input line after dropping down to 0V, or reset by ON/OFF control function.

Verifying OVP function shall be done by increasing output voltage with external resistor. For verifying OVP function, avoid applying external voltage to output terminal because this will cause power supply damage.

7-9. Over Temperature Protection (OTP)

This power module has built-in OTP function.

This function operates and shuts down the output when ambient temperature or internal temperature of power module abnormally rises. OTP operates at 105°C to 120°C base-plate temperature.

When module shut down due to over temperature, output will recover when cool down the base-plate.

For the "/LC" model need cool down the base-plate sufficiently and recycle output either by, recycling the input line after dropping down to 0V, or reset by ON/OFF control function.

However, take note that OTP will operate again unless the cause of abnormal heat of the power module is eliminated.

7-10. Remote Sensing (+S, -S Terminal)

Remote sensing terminal is provided to compensate for voltage drop across the wirings from the power supply output terminal to the load input terminal.

Recommended capacitor value of C8 is as same as C7.

When remote sensing function is not used (local sensing), short +S terminal to +V terminal and, -S terminal to -V terminal.

When using remote sensing function, output power of power module should be within maximum output power.

Also, use within maximum output adjustable voltage at output terminal.

Moreover, take note that allowable maximum output current which can be used becomes less than the specification when output terminal voltage is set higher than rated voltage. (Allowable Maximum Output Current = Maximum Output Power's specification ÷ Output terminal Voltage)

When wire is long, Power Supply operation might be unstable due to noise. Moreover, please do enough prior evaluation for remote sensing function by using shielded wire, twist pair, or parallel pattern.

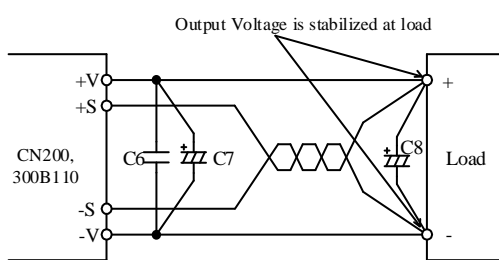

Fig.7-12 Remote Sensing is used

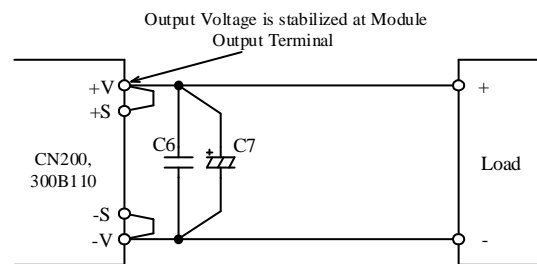

Fig.7-13 Remote Sensing is not used
(Local Sensing)

7-11. ON/OFF Control (CNT Terminal)

Without turning the input supply on and off, the output can be enabled and disabled using this function. This function also can be used for output sequence of plural power supply. ON/OFF control circuit is on the primary side (the input side). For secondary control or input filter is externally attached, isolation can be achieved through the use of a photo-coupler or equivalent.

Table.7-4 CNT Terminal Level

CNT Terminal Level to -Vin Terminal	Output Status
H Level ($4V \leq H \leq 30V$) or Open	OFF
L Level ($0V \leq L \leq 0.8V$) or Short	ON

- Note)
1. When ON/OFF control function is not used, CNT terminal should be shorted to -Vin terminal.
 2. When using long wiring, for prevention of noise, attach about 0.1uF capacitor between CNT terminal and -Vin terminal.
 3. At L level, source current from CNT terminal to -Vin terminal is 0.2mA~0.3mA
 4. The maximum CNT terminal voltage is 30V.

(1) Output ON/OFF control

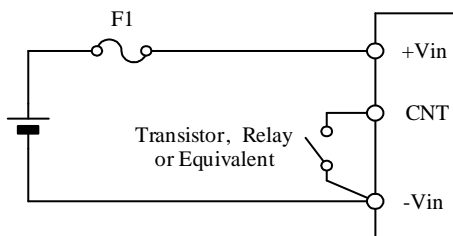

Fig.7-14 CNT Connection (1)

(2) Secondary (output side) control

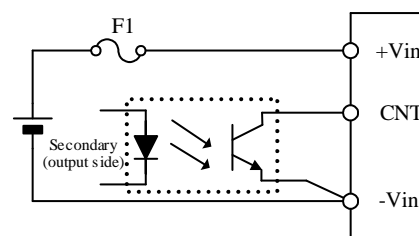

Fig.7-15 CNT Connection (2)

7-12. Parallel Operation (PC Terminal)

By connecting the PC terminal of each power module, output current can be equally drawn from each module. A maximum of 11 units of the same model can be connected. Furthermore, be sure that the output power of every module does not exceed the maximum output power value.

However, maximum output current is derated by parallel operation units as shown in Table 7-5. Note that usage of power module at out-of-rated condition might result in power module temperature abnormal rise or damage.

Table.7-5 Condition for parallel operation

Parallel units	Maximum output current
~5 units	95% of nominal output current
6~11 units	90% of nominal output current

Set the accuracy of the output voltage within +/-1% when adjust the output voltage for parallel operation.

(a) Parallel connection to enhance the output and to improve the reliability

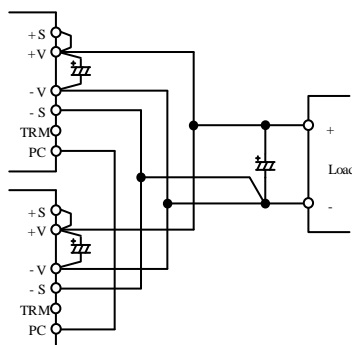

Fig.7-16 PC terminal Connection

(b) Parallel connection for programmed output voltage

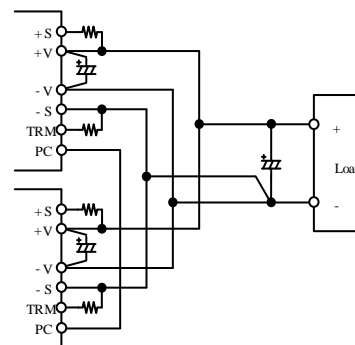

Fig.7-17 Programmed Output Voltage

(c) Parallel connection for variable output voltage (by External Variable Resistor)

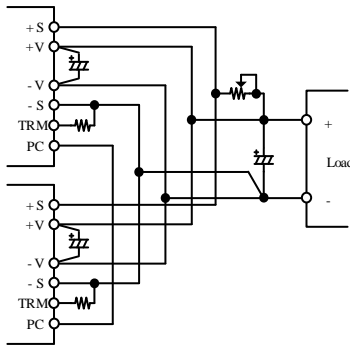

Fig.7-18 Variable Output Voltage (by External Variable Resistor)

(d) Parallel connection for variable output voltage (by Applied External Voltage)

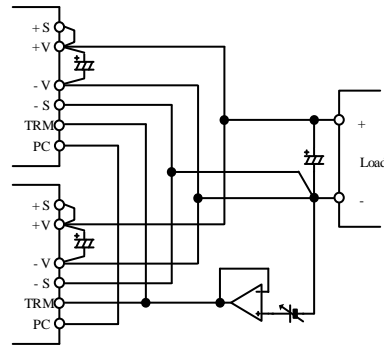

Fig.7-19 Variable Output Voltage (by Applied External Voltage)

7-13. Series Operation

Series operation is possible for CN200,300B110 series.

Connections shown in Fig. 7-20 and Fig. 7-21 are possible.

Moreover, contact us regarding the maximum allowable number of device connection.

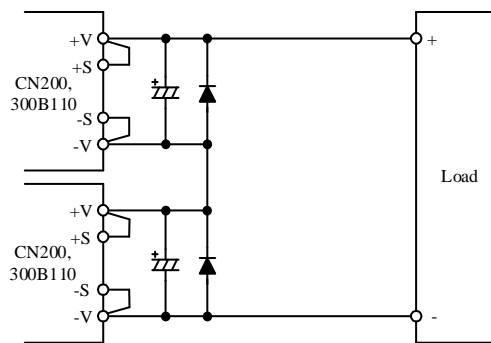

Fig.7-20 Series Operation for High Output Voltage

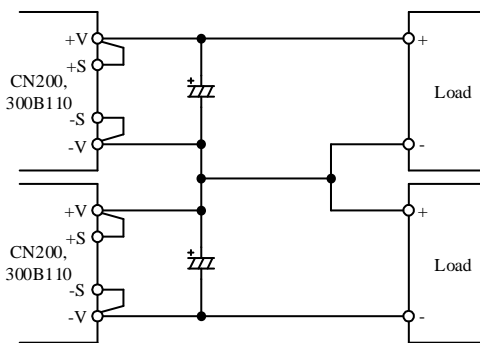

Fig.7-21 ±Output Series Operation

Note) The rating of the external diode should be as follows:

Forward current I_F : Can withstand the OCP value of CN200,300B110.

Reverse voltage V_R : About twice the output voltage of CN200,300B110.

7-14. Redundant Operation

Redundant operation is possible for loads that are within the maximum one power supply. When one module is shut-down by the power failure etc., another one can continue to provide power.

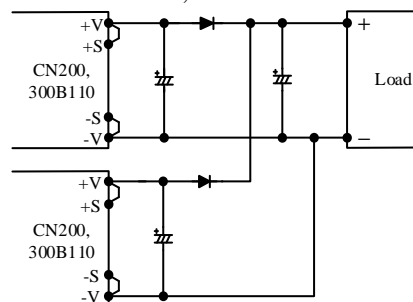

Fig.7-22 Redundant Operation Connection

Note) 1. In redundant operation, the remote sensing cannot be done.

2. For details on parallel redundant application, refer to Application Notes "Parallel Operation Application".

7-15. I.O.G Signal (IOG Terminal)

Normal or abnormal operation of the power module can be monitored by using the IOG terminal. Output of this signal monitor is located at secondary side (output side) and is an open collector output. This signal is LOW when converter is normally operating and HIGH when converter stops or when inverter is operating abnormally.

Maximum sink current	:	5mA
Maximum applied voltage	:	25V

Ground for the IOG terminal is the -S terminal.

Also note that IOG becomes unstable for following conditions:

- Operation of Over Current Protection (OCP)
- Operation at light load in parallel operation

7-16. Auxiliary Power Supply for External Circuits (AUX Terminal)

For AUX terminal, output voltage value is within 10~14VDC range, maximum output current is 10mA.

Ground for the AUX terminal is -S terminal.

Avoid short circuit of AUX terminal with other terminals as this would lead to power module damage.

7-17. Operating Ambient Temperature

There is no restriction on mounting direction but there should be enough consideration for airflow so that heat does not accumulate around the power supply vicinity.

Determine external components configuration and mounting direction on PCB such that air could flow through the heatsink at forced cooling and conduction cooling.

By maintaining actual ambient temperature below 85°C and base-plate temperature below 100°C, operation is possible. For details on thermal design, refer to Application Notes "Thermal Design".

- Note) 1. Maximum base-plate temperature is 100°C. For worst case operating condition, verify base-plate temperature at measurement point indicated in Fig. 7-23. Moreover, ambient air temperature shall be confirmed at a point 10 mm or less from the power supply side. Use below 85°C ambient temperature.

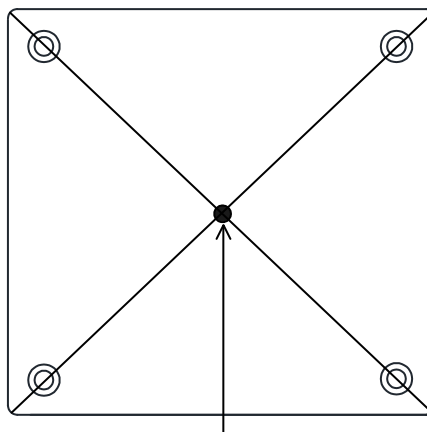

Measurement Point of Base-plate Temperature

Fig.7-23 Measurement Point of Base-plate Temperature

2. There is limitation on baseplate temperature range for as shown in Fig 7-24.

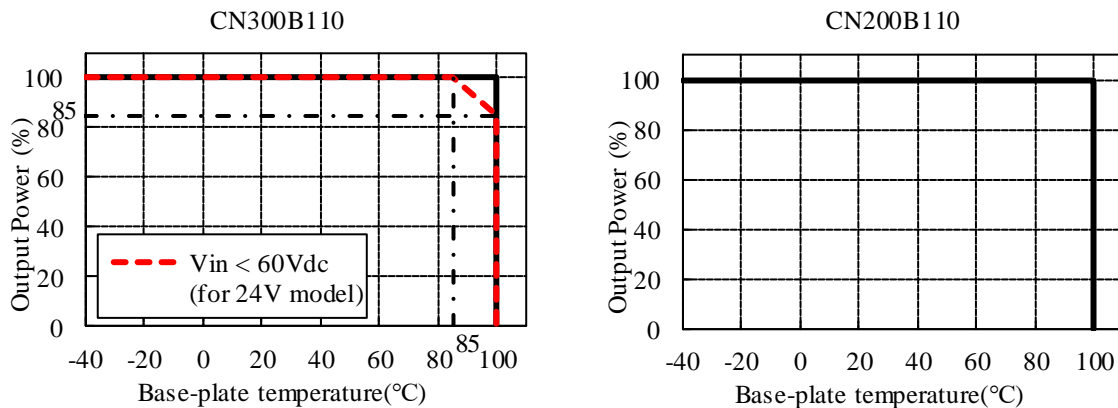

Fig.7-24 Derating Curve

To further improve reliability, it is recommended to use this power supply with ambient temperature and base-plate temperature derating.

7-18. Operating Ambient Humidity

Take note that condensation could lead to power supply abnormal operation or damage.

7-19. Storage Ambient Temperature

Take note that sudden temperature changes can cause condensation buildup, and other harmful affects to each terminal solder.

7-20. Storage Ambient Humidity

Take enough care when storing the power module because rust which causes poor solderability would form in each terminal when stored in high temperature, high humidity environment.

7-21. Cooling Method

Operating temperature range is specified by the base-plate temperature. Therefore, several methods of heat dissipation are possible.

For details on thermal design, refer to Application Notes "Thermal Design".

7-22. Withstand Voltage

This power module is designed to have a withstand voltage of 3kVAC between input and output, 2.5kVAC between input and base-plate and 500VAC between output and base-plate for 1 minute.

When conducting withstand voltage test during incoming inspection, set the current limit value of the withstand voltage testing equipment to 20mA.

Furthermore, avoid throw in or shut off of the testing equipment when applying or when shutting down the test voltage. Instead, gradually increase or decrease the applied voltage. Take note especially not to use the timer of the test equipment because when the timer switches the applied voltage off, impulse voltage which has several times the magnitude of the applied voltage is generated causing damage to the power supply.

Connect the terminals as shown in the diagram below.

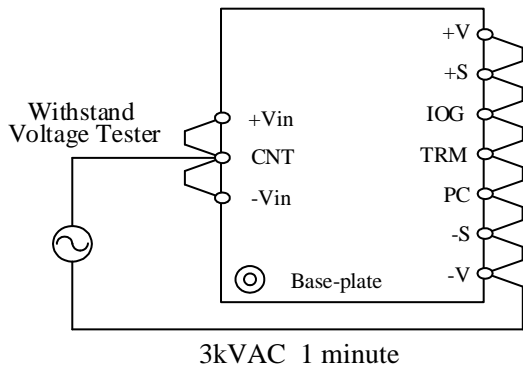

Fig.7-25 Withstand Voltage Test for Input - Output

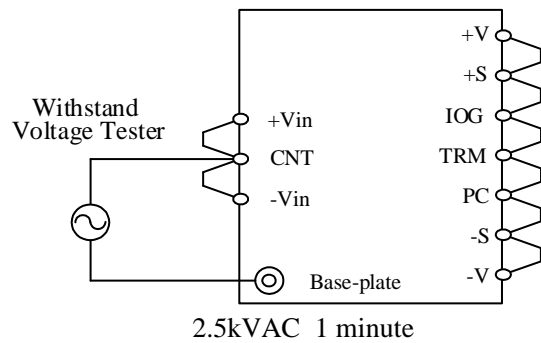

Fig.7-26 Withstand Voltage Test for Input - Base-plate

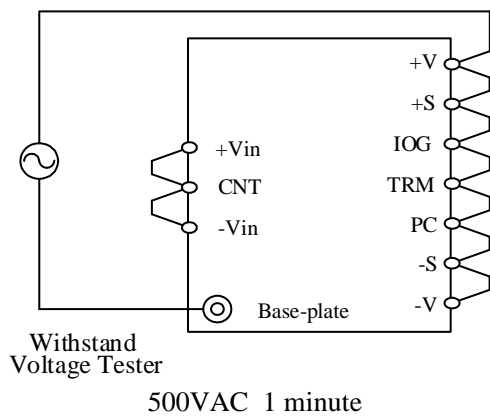

Fig.7-27 Withstand Voltage Test for Output - Base-plate

Withstand Voltage Testing with External Application

The above Withstand Voltage Testing specification applies only to power supply as stand-alone unit. Please take note of the following points when Withstand Voltage Testing is performed with attached external application.

For applications that require external capacitor connections between input - base-plate and output - base-plate as shown in the Fig. 7-28, when testing withstand voltage between input - output, Voltage Divider Ratio between input - base-plate and output - base-plate will be affected by each total capacitance value ratio between the input - base-plate and output - base-plate.

When selecting each external capacitor, take care of the capacitance value and voltage rating.

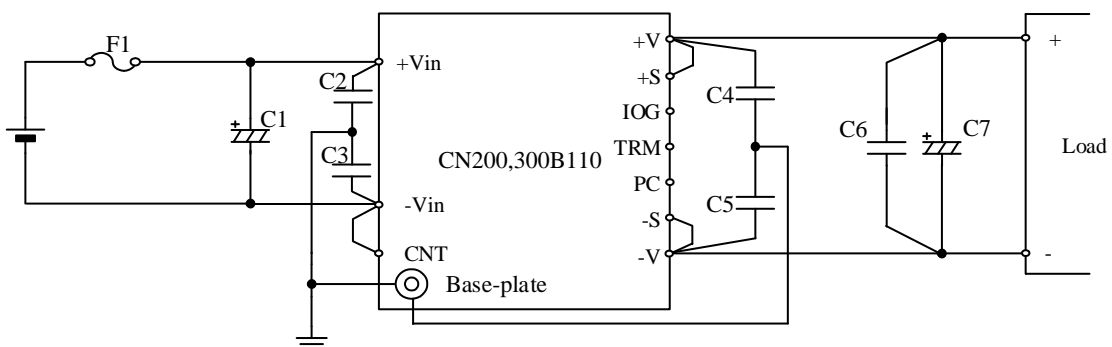

Fig.7-28 Example of connecting external application

7-23. Isolation Resistance

Use DC isolation tester (MAX 500V) between output and base-plate. Isolation resistance value is 100M Ω and above at 500VDC applied voltage. Make sure that during testing, the isolation testers do not generate a high pulse when the applied voltage is varied.

Ensure that the tester is fully discharged after the test.

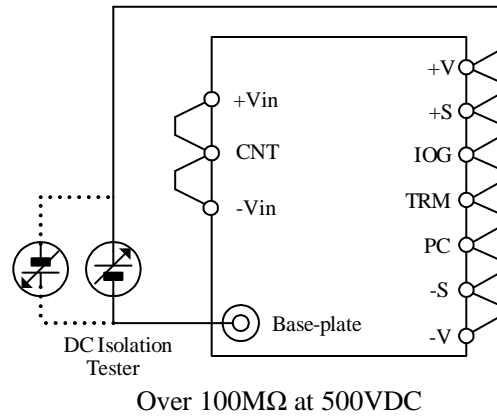

Fig.7-29 Isolation Resistance Test

7-24. Vibration

Vibration of power supply is defined when mounted on printed circuit board.

For details, refer to “8. Mounting Method”.

7-25. Shock

Withstand shock value is defined to be the value at TDK-Lambda shipment and packaging conditions, or when mounted on printed circuit board.

When mounting on printed circuit board, refer to “8. Mounting Method”.

8. Mounting Method

8-1. Mounting Method

By the following instruction shown in Fig. 8-1, mount power supply onto printed circuit board.

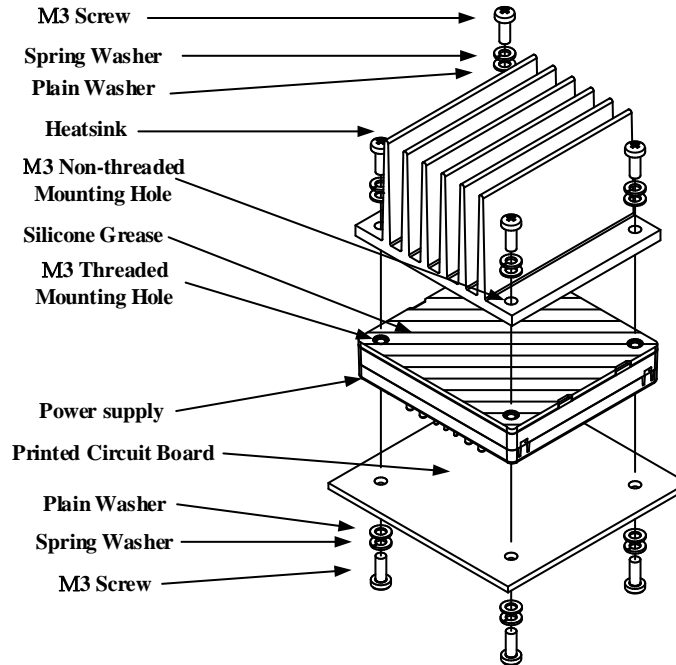

(a) Standard Mounting Method

Note:
 Different from above standard type, the mounting holes of /T option's heatsink are threaded. Since there is no optional heatsink (refer to chapter 11) for the /T type of CN200,300B110, users need to prepare another one or use other feasible solutions.

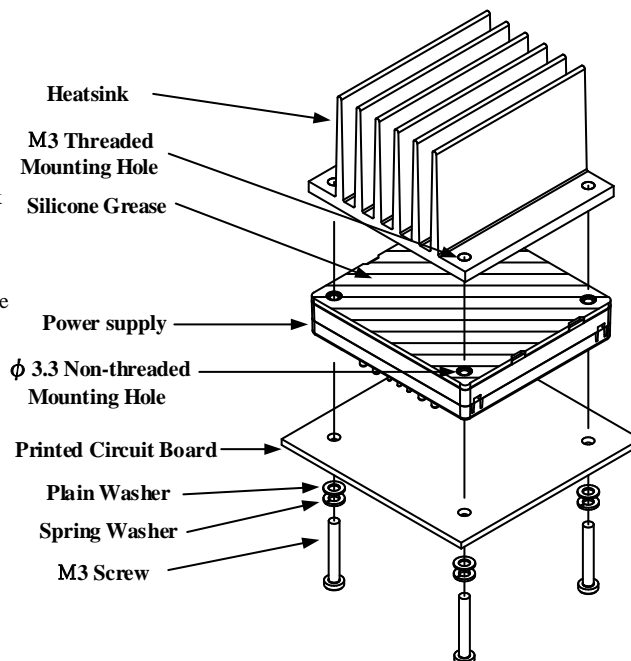

(b) /T option Mounting Method

Fig.8-1 Mounting Method

(1) Method to Fixing on Printed Circuit Board

To fix a power module onto printed circuit board, use M3 screws and mount it to the M3 threaded holes of the power module. Recommended torque is 0.54N·m.

(2) Mounting Holes (/T option is $\phi 3.3$ non-threaded)

Mounting holes of the power supply are connected to base-plate. Connect base-plate to FG (Frame Ground) by using this mounting holes.

(3) Mounting Holes on Printed Circuit Board

Refer to the following sizes when determining diameter of hole and land diameter of printed circuit board.

Input / Signal terminals ($\phi 1.0$ mm)

Hole diameter : $\phi 1.5$ mm

Land diameter : $\phi 2.5$ mm

Output terminals ($\phi 2.0$ mm)

Hole diameter : $\phi 2.5$ mm

Land diameter : $\phi 4.8$ mm

Mounting Holes (FG)

Hole diameter : $\phi 3.5$ mm

Land diameter : $\phi 7.0$ mm

For position of the holes, see outline drawing of the power supply.

(4) Recommended Material of PCB

Recommended materials of the printed circuit board is double sided glass epoxy with through holes. (thickness t:1.6mm , copper 35 μ m or more)

(5) Input / Output Pattern Width

Large current flows through input and output pattern. If pattern width is too narrow, heat on pattern will increase because of voltage drop of pattern. Relationship between allowable current and pattern width varies depending on materials of printed circuit board, thickness of conductor. It is definitely necessary to confirm on manufacturers of printed circuit board for designing pattern.

(6) Method of Connecting Terminals

Connect +Vin, -Vin, +V, -V with consideration of contact resistance .

8-2. Notes on Designing PWB for Power Module Mounting

In order to satisfy withstand voltage specification for this power module, it is recommended to keep following all distances for each pattern wiring and mounting components distance of primary circuit (Input), secondary circuit (Output) and FG(Baseplate).

Primary circuit - Secondary circuit : 7.0mm or more
Primary circuit - FG : 4.5mm or more
Secondary circuit - FG : 3.0mm or more

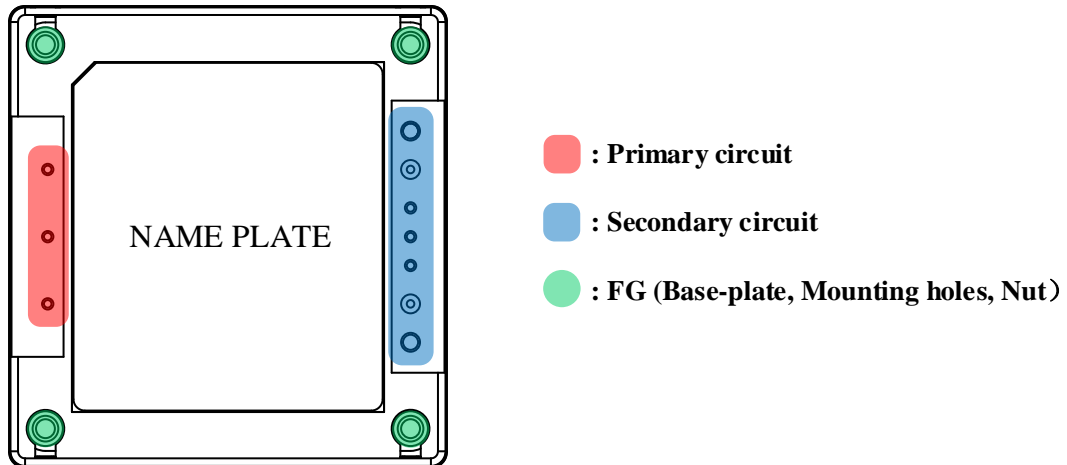

Fig.8-2 Connection potential of each terminal

8-3. Heatsink Installation Method

(1) Method of Fixing Heatsink

(1-1) Standard model

To fix the heatsink onto power module, use M3 screws and mount it to the M3 threaded holes (4 places) at the base-plate side. Recommended torque is 0.54 N·m.

(1-2) /T option model

To fix the heatsink onto power module, use M3 screws those are the same screws for mounting power module onto printed circuit board.

Use silicone grease or thermal conductive sheet in between heatsink and base-plate to minimize the contact thermal resistance and to enhance the heat conductivity.

Also use the no-warped heatsink and make sure good contact between base-plate and heatsink.

(2) Mounting Hole of Heatsink

Recommended mounting hole is as follows.

(2-1) Standard model $\phi 3.5$ Non-threaded hole

(2-2) /T option model M3 Threaded hole

8-4. Regarding Vibration

The vibration specification of the power supply is determined assuming that only the power supply is mounted on printed circuit board. To prevent excessive force to the power supply and the printed circuit board, fix the heatsink to the chassis as well as to the power supply when a large size of heatsink is used.

8-5. Recommended Soldering Condition

Recommended soldering conditions are as follows.

Soldering is guaranteed only one time under either (1) or (2) below.

It is without guarantee and please evaluate enough if soldering twice or more.

(1) Soldering dip

Dip condition : 260°C within 10 seconds

Pre-heat condition : 110°C for 30 - 40 seconds

(2) Soldering iron

350°C within 3 seconds

Note) Soldering time changes according to heat capacity of soldering iron, pattern on printed circuit board, etc. Please confirm actual performance.

8-6. Recommended Cleaning Condition

Recommended cleaning condition after soldering is as follows.

(1) Cleaning solvent

IPA (isopropyl alcohol)

(2) Cleaning Procedure

Use brush and dry the solvent completely.

9. Before Concluding Power Module Damage

Verify following items before concluding power supply damage.

(1) No output voltage

- Is specified input voltage applied?
- Are the ON/OFF control terminal (CNT), remote sensing terminal (+S, -S), output voltage trimming terminal (TRM) correctly connected?
- For cases where output voltage adjustment is used, is the resistor or variable resistor setting, connections correctly done?
- Are there no abnormalities in the output load used?
- Is the base-plate temperature within the specified temperature range?
- Is the room temperature within the specified temperature range?

(2) Output voltage is high

- Are the remote sensing terminals (+S, -S) correctly connected?
- Is the measurement done at the sensing points?
- For cases where output voltage adjustment is used, is the resistor or variable resistor setting, connections correctly done?
- Are there no abnormalities in the output load used?

(3) Output voltage is low

- Is specified input voltage applied?
- Are the remote sensing terminals (+S, -S) correctly connected?
- Is the measurement done at the sensing points?
- For cases where output voltage adjustment is used, is the resistor or variable resistor setting, connections correctly done?
- Are there no abnormalities in the output load used?

(4) Load regulation and line regulation is large

- Is specified input voltage applied?
- Are the input terminals and the output terminals firmly connected?
- Is the measurement done at the sensing points?
- Is the input or output wire too thin?

(5) Output ripple voltage is large

- Is the measurement done according to methods described in the Instruction Manual or is it an equivalent method?
- Is the input ripple voltage value within the specified value?

10. Warranty Period

Warranty period is 5 years.

For damages occurring at normal operation within this warranty period, change is free of charge.

Following cases are not covered by warranty

- (1) Improper usage like dropping products, applying shock and defects from operation exceeding specification of the unit.
- (2) Defects resulting from natural disaster (fire, flood etc.)
- (3) Unauthorized modifications or repair by the buyers' defects not cause by our company.

11. Option Heatsink

Model	Heatsink	Size (W×H×Dmm)	Thermal Resistance *1
CN200,300B110	HAH-15L	61×38.1×57.9	3.4 °C/W

*1 : at convection cooling

(Convection cooling)
 Thermal resistance : 3.4 °C/W

(Forced air cooling)

HAH-15L (CN200,300B110)

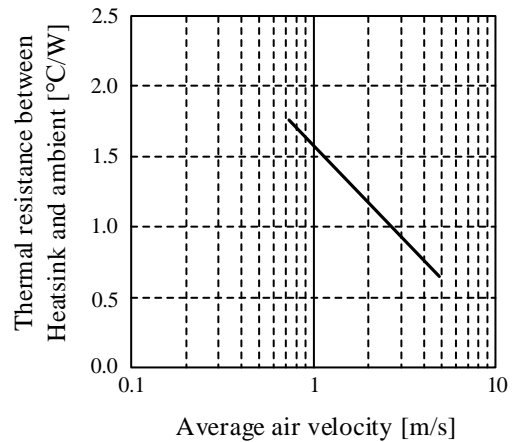
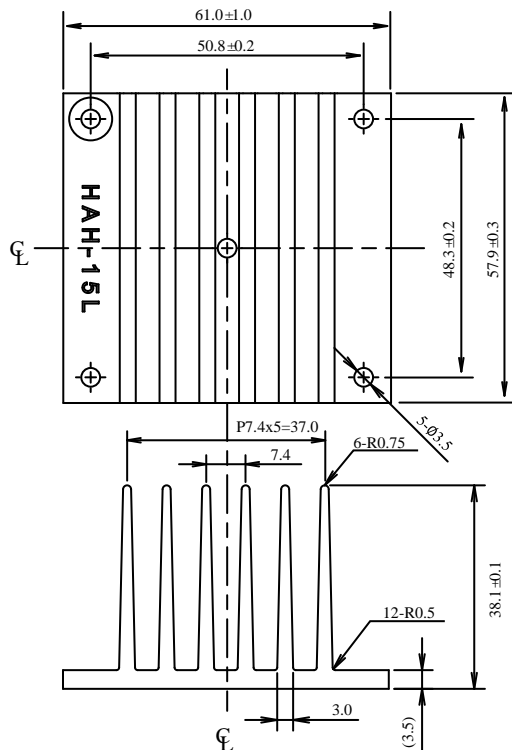

12. CE Marking/UKCA Marking

CE Marking

CE Marking, when applied to a product or packing material for a product covered by this handbook, indicates compliance with the Low Voltage Directive and RoHS Directive.

UKCA Marking

UKCA Marking, when applied to a product or packing material for a product covered by this handbook, indicates compliance with the Electrical Equipment (Safety) Regulations and Restriction of the Use of Certain Hazardous Substances in Electrical & Electronic Equipment Regulations.