

# PAF600F280 SERIES

## Instruction Manual

### ■ BEFORE USING THE POWER SUPPLY UNIT

Be sure to read this instruction manual thoroughly before using this product. Pay attention to all cautions and warnings before using this product. Incorrect usage could lead to an electrical shock, damage to the unit or a fire hazard.

### ■ DANGER

- Never use this product in locations where flammable gas or ignitable substances are present.

### ■ INSTALLATION WARNING

- When installing, ensure that work is done in accordance with the instruction manual. When installation is improper, there is risk of electric shock and fire.
- Installation shall be done by Service personnel with necessary and appropriate technical training and experience. There is a risk of electric shock and fire.
- Do not cover the product with cloth or paper etc. Do not place anything flammable around. This might cause damage, electric shock or fire.

### ■ WARNING on USE

- Do not touch this product or its internal components while circuit in operation, or shortly after shutdown. You may receive a burn.
- While this product is operating, keep your hands and face away from it as you may be injured by an unexpected situation.
- There are cases where high voltage charge remains inside the product. Therefore, do not touch even if they are not in operation as you might get injured due to high voltage and high temperature. You might also get electric shock or burn.
- Do not make unauthorized changes to this product nor remove the cover as you might get an electric shock or might damage the product. We will not be held responsible after the product has been modified, changed or disassembled.
- Do not use this product under unusual condition such as emission of smoke or abnormal smell and sound etc. Please stop using it immediately and shut off the product. It might lead to fire and electric shock. In such cases, please contact us. Do not attempt repair by yourself, as it is dangerous for the user.
- Do not operate and store these products in environments where condensation occurs due to moisture and humidity. It might lead fire and electric shock.
- Do not drop or apply shock to this product. It might cause failure. Do not operate these products mechanical stress is applied.

## ■ CAUTION on MOUNTING

- Confirm connections to input terminals, output terminals and signal terminals are correct as indicated in the instruction manual before switching on.
- Do not operate the product with condensation. It might cause electric shock or fire may occur.
- Input line and output line, please use the wires as short and thick as possible.
- Do not use this product in special the environment with strong electromagnetic field, corrosive gas or conductive substances and direct sunlight, or places where product is exposed to water or rain.
- Please shut down the input when connecting input and output of the product.
- When installing in environment where conductive foreign matter, dust and liquid may be present, please consider to avoid the above foreign materials infiltration into the power supply by installing filter, to prevent trouble or malfunction.

## ■ CAUTION on USE

- Product individual notes are shown in the instruction manual. If there is any difference with common notes, individual notes shall have priority.
- Before using this product, be sure to read the catalog and instruction manual. There is risk of electric shock or damage to the product or fire due to improper use.
- Input voltage, Output current, Output power, Base-plate temperature, ambient temperature and ambient humidity should be kept within specifications, otherwise the product will be damaged or malfunctioned, or cause electric shock or fire.
- For products without built-in protection circuit (element, fuse, etc.), insert fuse at the input to prevent smoke, fire during abnormal operation.
- For externally mounted fuse do not use other fuses aside from our specified and recommended fuse.
- If the external fuse is blown, do not use the product even after replacing the fuse, as there is risk of abnormality inside. Be sure to request repair to our company.
- As our product is standard industrial use product that was manufactured by purpose that is used to a general electronics equipment etc., it is not products that to designed for High Safety uses (Uses extremely high reliability and safety are required, if reliability and safety has not been secured, with significant dangerousness for directly life or body) is expected. Please consider a fail-safe (systems that was provided with protection circuit protective devices or systems that redundant circuit was mounted so that was not unstable in single failure) design enough.
- When used in environments with strong electromagnetic field, there is possibility of product damage due to malfunction.
- When used in environment with corrosive gas (hydrogen sulfide, sulfur dioxide, etc.), there is possibility that they might penetrate the product and lead to failure.
- When used in environments where there is conductive foreign matter, dust or liquid, there is possibility of product failure or malfunction.
- Provide countermeasure for prevention of lightning surge voltage as there is risk of damage due to abnormal voltage.
- Connect together the frame ground terminal of the product and the ground terminal of the equipment for safety and noise reduction. If these ground is not connected together, there is risk of electric shock.
- Take care not to apply external abnormal voltage to the output terminals and signal terminals. Especially, applying reverse voltage or overvoltage more than the rated voltage to the output might cause failure, electric shock or fire.
- Never operate the product under overcurrent or short circuit condition. Insulation failure, or other damages may occur.

- On the occasion of obtain of Safety Standard, this power supply is not considered for connect between +Vin terminal and earth.
- The outputs of this product may exceed ESI limits under fault conditions. The outputs must be protected in the end equipment to maintain ESI.
- The output power of this product is considered to be hazardous energy level(The voltage is more than or equal to 2V and the power is more than equal to 240VA). It must not be made accessible to users. Protection must be provided for service engineers against indirect contact with the output terminal and to prevent any tools drop across the outputs. while working on this product, the DC input must be switched off and the input and output voltage should be zero.
- The application circuits and their parameters are for reference only. Be sure to verify effectiveness of these circuits and their parameters before finalizing the circuit design. Moreover, we will not be responsible on application patent or utility model.

## ■ Note

- When disposing product, follow disposal laws of each municipality.
- Published EMI (CE, RE) or immunity is the result when measured in our standard measurement conditions and might not satisfy specification when mounted and wired inside end-user equipment.  
Use the product after sufficiently evaluating at actual end-user equipment.
- When exporting our products, apply for necessary permissions as required by rules and regulations of Foreign Exchange and Foreign Trade Control Act.
- The information in the catalog or the instruction manual is subject to change without prior notice. Please refer to the latest version of the catalog or the instruction manual.
- No part of this document may be copied or reproduced in any form without prior written consent TDK-Lambda.

## ■ LONG-TERM STORAGE METHOD AND LONG-TERM STORAGE PERIOD

- Please keep the product in carton box.
- Please do not apply excessive vibration, shock or mechanical stress applied directly to the product.
- Please keep away from direct sunlight.
- For long-term storage temperature and humidity, the following conditions shall be used as a guideline:  
Temperature range : 5°C~30°C  
Humidity range : 40%~60%RH  
Please keep away from the places where temperature and humidity can change drastically.  
It can cause condensation on the product or deterioration.
- For long-term storage period, we recommend to use within 2 years after receiving the product.  
For products that have been received for more than 1 year, please check lead oxidation and solderability.  
In addition, SMD type products may have MSL (Moisture Sensitivity Level) provision.  
Please be sure to read the instruction manual and delivery specifications.

## Table of Contents

### ■ Block Diagram

### ■ Sequence Time Chart

### ■ Terminal Explanation

### ■ Explanation on Specifications

1. Input Voltage Range
2. Output Voltage Adjustment Range
3. Maximum Output Ripple and Noise
4. Maximum Line Regulation
5. Maximum Load Regulation
6. Over Current Protection (OCP)
7. Over Voltage Protection (OVP)
8. Over Thermal Protection(OTP)
9. Remote Sensing (+S, -S terminal)
10. ON/OFF Control (CNT,SG terminal)
11. Parallel Operation (PC terminal)
12. Series Operation
13. I.O.G. signal (IOG terminal)
14. Auxiliary power supply for external signals  
(AUX terminal)
15. Operating Ambient Temperature
16. Operating Ambient Humidity
17. Storage Ambient Temperature
18. Storage Ambient Humidity
19. Cooling Method
20. Baseplate Temperature vs. Output Voltage Drift
21. Withstand Voltage
22. Insulation Resistance
23. Withstand Vibration
24. Withstand Shock
25. CE MARKING / UKCA MARKING
26. Parallel Operation Precautions

### ■ Before concluding module damage

# PAF600F280-SERIES

## Block Diagram

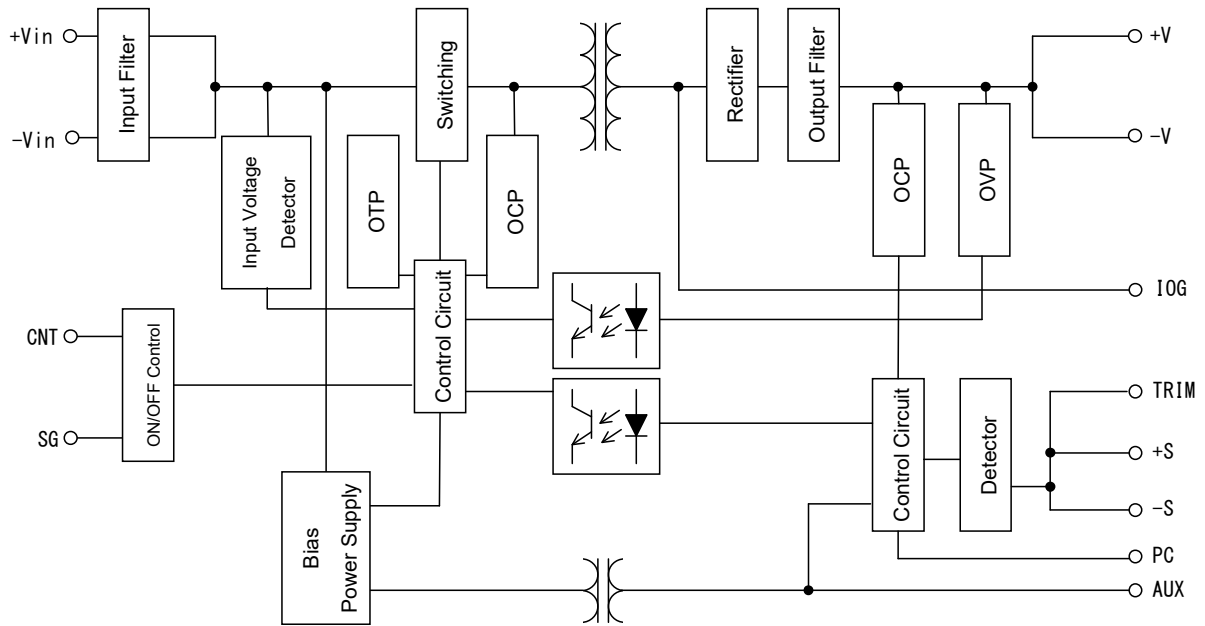

Switching Frequency : 200kHz

## Sequence Time Chart

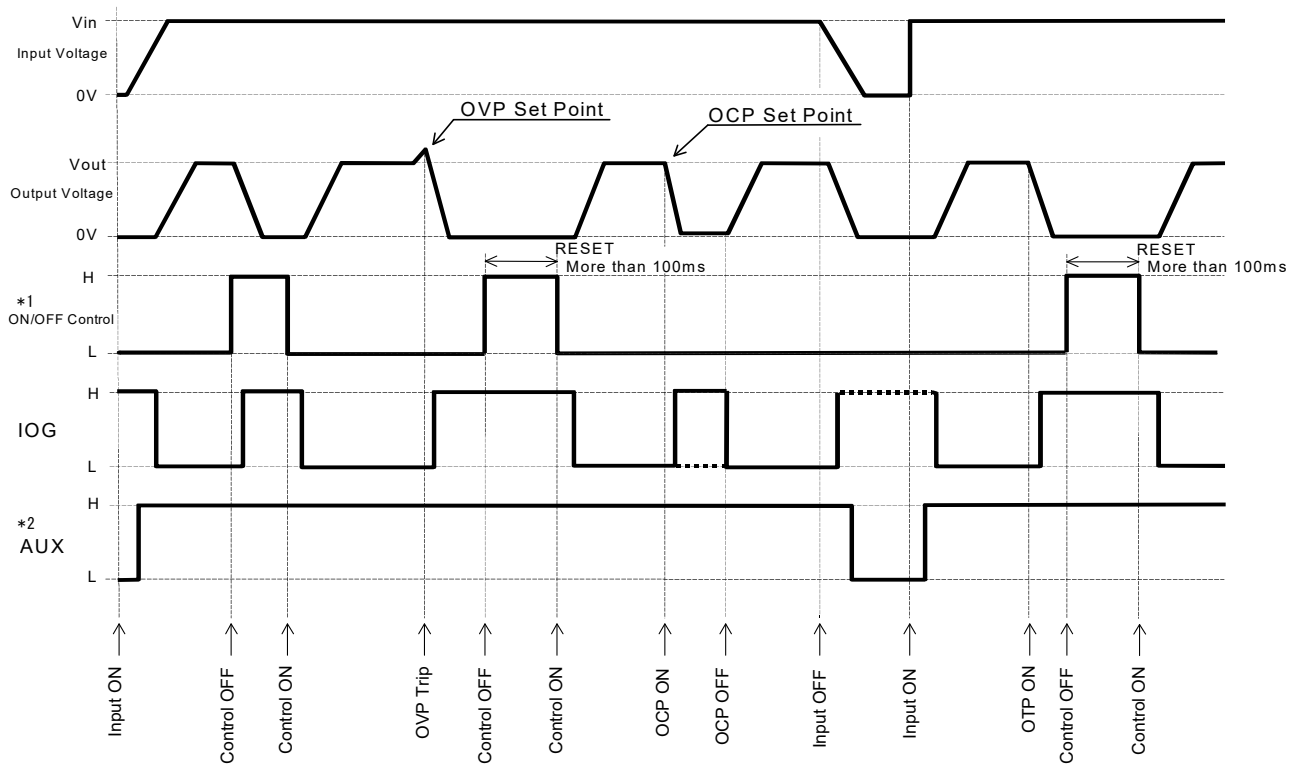

\*1 Level :  $4 \leq H \leq 35(V)$  or Open  
 $0 \leq L \leq 0.8(V)$  or Short

\*2 H Level : 10~14VDC

# PAF600F280-SERIES

## Terminal Explanation

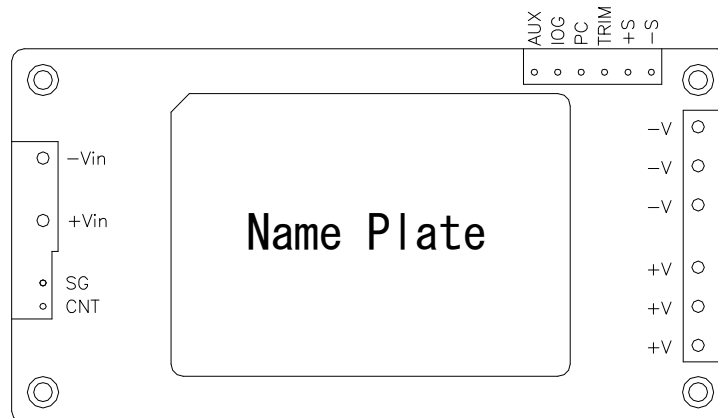

### [Input Side Terminals]

+Vin : +Input Terminal  
-Vin : -Input Terminal

### [Control Terminals]

CNT : ON/OFF Control terminal  
SG : ON/OFF Control (ground side) terminal

### [Output Side Terminals]

+V : +Output Terminal  
-V : -Output Terminal

+S : +Remote Sensing  
-S : -Remote Sensing  
TRIM : Output Voltage Trimming Terminal  
PC : Output Current Balance Terminal  
IOG : Inverter Operation Good  
AUX : Auxiliary Power Supply

for External Signals

Baseplate can be connected to FG through M3 mounting tapped holes.  
Connect +Vin, -Vin, +V, -V with consideration of contacting resistance.

## ■ Explanations on Specifications:

### 1. Input Voltage Range

Input voltage range for PAF600F280 Series is indicated below.

**Input Voltage Range : 200~400VDC**

Basically, ripple voltage ( $V_{rpl}$ ) which results from rectification and filtering of commercial AC line is included within the input voltage as shown in Fig. 1-1. Ripple voltage must be limited within the voltage described below.

**Allowable input ripple voltage : 20Vp-p**

When this value is exceeded, the output ripple voltage becomes large.

Note that sudden input voltage change may cause variation of output voltage transitionally.

Also, input voltage waveform peak value must not exceed above input voltage range.

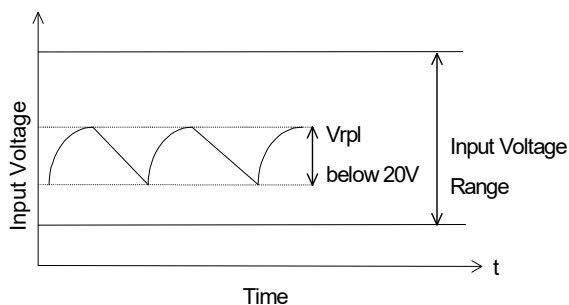

Fig.1-1 Ripple Voltage

### ● Basic Connection

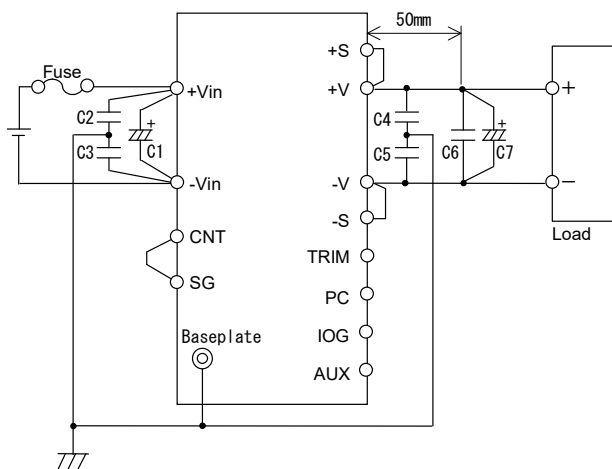

Fig.1-2 Basic Connection

### Input Fuse

This power module has no built-in fuse. Use external fuse to acquire various Safety Standards and to improve safety. Also, use fast-blow type or normal-blow type for every module.

**Input Fuse recommended current rating: 6.3A (400VDC)**

### C1 :

To prevent the effect of input line inductance to the power module, connect electrolytic capacitor or ceramic capacitor between +Vin and -Vin terminals.

Furthermore, use electrolytic capacitor with small ESR value. Especially take note that during line turn off at low ambient temperature, power module output will not normally shut down due to unstable C1 voltage.

Also, ripple current flows across this capacitor. Therefore, verify maximum allowable ripple current this capacitor when selecting component. Verify actual ripple current value by actual measurement.

### Recommended capacitor value

**: 22  $\mu$  F and above (voltage rating 400V and above)**

Note) 1. Use low impedance electrolytic capacitor with excellent temperature characteristics.

2. When input line inductance becomes excessively high due to insertion of choke coil, operation of the power module could become unstable. For this case, increase C1 value more than the value indicated above.

3. When ambient temperature becomes lower than  $-20^{\circ}\text{C}$ , connect four capacitors indicated above in parallel because output fall characteristics could be affected by ESR.

### C2, C3 : 330pF

To reduce spike noise voltage at the output, connect the high withstand voltage ceramic capacitor from +Vin terminal, -Vin terminal to the baseplate.

**Withstand Voltage of C2,C3 : 3KVac and above**

Note) 1. Connect the C2 between +Vin terminal and baseplate, and the C3 between -Vin terminal and baseplate with the short connections as possible.

# PAF600F280-SERIES

2. There are cases where output ripple voltage could vary according to input wiring method or peripheral circuits. For this case, increase C2 and C3 value or connect common mode choke coil before C1.

### C4, C5 : 0.022 $\mu$ F

To reduce spike noise voltage at the output, connect a ceramic capacitor.

### Withstand voltage of C4,C5 : 500Vdc and above

Connect the C4 between +V terminal and baseplate, and the C5 between -V terminal and baseplate with the short connections as possible.

### C6 : 2.2 $\mu$ F

To reduce spike noise voltage at the output, connect a ceramic capacitor between +V and -V within 50mm distance from the output terminals.

Also, take note that output spike noise voltage could vary according to PCB wiring design.

### C7 :

For stable operation, connect an electrolytic capacitor between +V and -V at 50mm distance from the output terminals.

Take note that output ripple and output fall characteristics could be affected by electrolytic capacitor, equivalent impedance and inductance characteristics of wiring.

Take note that output ripple voltage could vary according to PCB wiring design.

For cases of abrupt changes in load current or input voltage, increasing capacitance value of the external capacitors could reduce the voltage fluctuation.

Vout	C7
12V	25V 1,000 $\mu$ F x 2 parallel
24V	50V 820 $\mu$ F
28V	50V 820 $\mu$ F
48V	50V 1,000 $\mu$ F x 2 series

**Table1-1 C7:Recommended Values of External Output Capacitor**

Note ) 1. Use low impedance electrolytic capacitor with excellent temperature characteristics. (Nippon Chemicon LXY Series or equivalent)

2. Use capacitors indicated in table 1-1 in parallel when ambient temperature becomes lower than  $-20^{\circ}\text{C}$  because output ripple voltage could be affected by ESR.

Quantities for capacitors are as follows.

Vout	C7
12V	25V 1,000 $\mu$ F x 4 parallel
24V	50V 820 $\mu$ F x 2 parallel
28V	50V 820 $\mu$ F x 2 parallel
48V	50V 1,000 $\mu$ F x 2 series, x 2 parallel

**Table1-2 C7:Recommended Values of External Output Capacitor ( $T_a < -20^{\circ}\text{C}$ )**

3. Take note of the allowable ripple current of the capacitor to be used. Especially, when load adding capacitors for abrupt current changes, be sure to verify that ripple current does not exceed allowable ripple current before use.

### C8 :

When switches or connectors are used between input source and PAF600F280 Series input terminals, impulse surge voltage is generated at input due to input throw-in by switch on/off or due to inserting/ removing of power module from the active line. For this case, connect an additional electrolytic capacitor C8 as shown in fig.1-3 and fig. 1-4.

### Recommended Capacitance Value

**: 10~47  $\mu$  F and above**

**(Voltage Rating 400V and above)**

Also, in-rush current flows at line throw-in. Therefore, be sure to verify capability of switch or fuse to withstand  $I^2t$  at line throw-in.

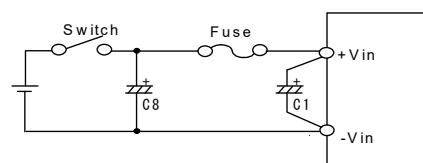

**Fig.1-3 Input Filter with Input Switch**

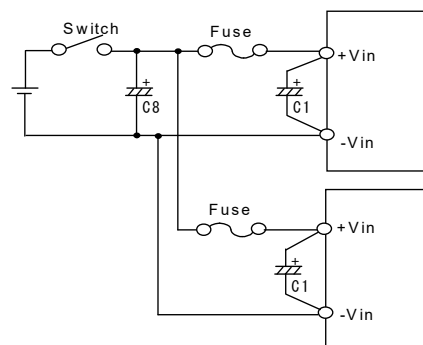

**Fig.1-4 Input Filter when Plural Power**



# PAF600F280-SERIES

## Reverse input connections

Reverse input polarity would cause module damage. For cases where reverse connections are possible, connect a protective diode and fuse. Use protective diode with higher voltage rating than the input voltage, and with higher surge current rating than the fuse.



Fig.1-5 Protection for Reversed Connection of Input

\* Recommended input filter as EMI countermeasure (conforms to VCCI Class A, FCC class A)

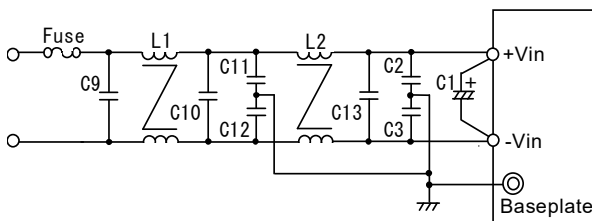

Fig.1-6 Recommended input filter as EMI countermeasure

### Recommended Values:

- C1 : 22  $\mu$  F (Electrolytic Capacitor)
- C2,C3,C11,C12 : 2200pF (Ceramic Capacitor)
- C9,C10,C13 : 0.68  $\mu$  F (Film Capacitor)
- L1 : 5 mH (Common mode choke coil)
- L2 : 3.8 mH (Common mode choke coil)

Note) 1. For the power module output, connect output capacitors described in the basic circuit connection.

2. VCCI Class A, FCC Class A limits can be satisfied with the above recommended filter at TDK-Lambda measuring conditions. However, there are cases where above limits might not be satisfied due to input and output wiring method, as well as, peripheral circuits. When selecting input filter, be sure to verify actual EMI characteristics (CE and RE) before finalizing the filter. Refer to PAF600F280-\* Evaluation Data for details.

## 2. Output Voltage Adjustment Range

Output voltage could be adjusted within the range described below by external resistor or variable resistor, or by applying external voltage. However, take note that OVP might trigger when output voltage adjustment exceeds the ranges indicated below.

### Output Voltage Adjustment Range -40% ~ +20% of Nominal Output Voltage

Furthermore, when increasing the output voltage reduce the output current so as not to exceed the maximum output power.

Also, take note that when output voltage is increased, input voltage range is limited as shown in fig. 2-1.

With the external circuit as shown in fig.2-2, remote sensing is possible even when output voltage is varied. For details on remote sensing function, please refer to "9. Remote Sensing"

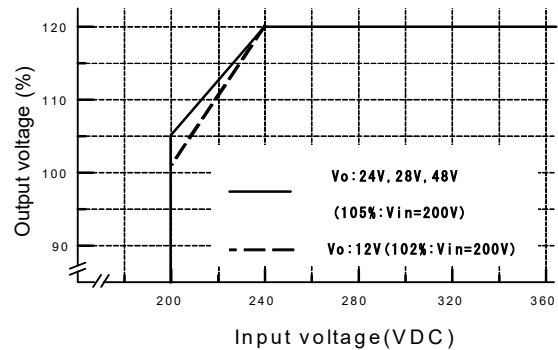

Fig.2-1 Limit of Input Voltage

### Output Voltage Adjustment by external resistor or by variable resistor

Resistor values, as well as, connecting methods for external resistor (R1) and external variable resistor (VR) are described below.

In this case, using VR as remote programming resistor, remote programming of output voltage can be possible.

Also, be sure to connect remote programming resistor between +S terminal and +V terminal.

	12V	24V	28V	48V
R1	6.8k	6.8k	6.8k	6.8 k
VR	20k	50k	50k	100k

Unit : [  $\Omega$  ]

External Resistor : below  $\pm 5\%$  Tolerance  
Variable Resistor : below  $\pm 20\%$  Tolerance  
below 1% Remain

Table2-1 Values of External Resistor and Variable Resistor  
-40% ~ +20% Variable

# PAF600F280-SERIES

	12V	24V	28V	48V
R1	43k	43k	43k	43k
VR	5k	10k	10k	20k

Unit : [ $\Omega$ ]

External Resistor : below  $\pm 5\%$  Tolerance  
 Variable Resistor : below  $\pm 20\%$  Tolerance  
 below 1% Remain

**Table2-2 Values of External Resistor and Variable Resistor  $\pm 10\%$  Variable**

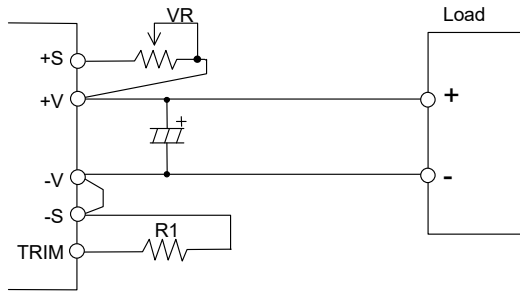
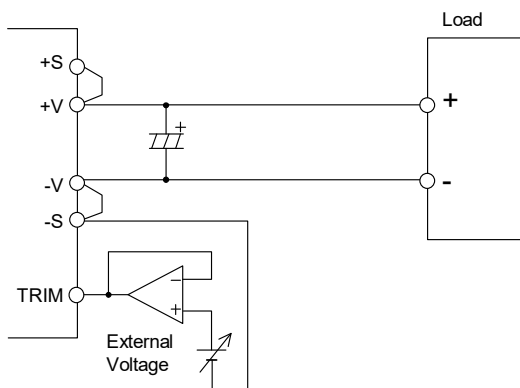

**Fig.2-2 Example Connection of External Resistor**

## Output Voltage Adjustment by applying external voltage

By applying external voltage at the TRIM terminal, output voltage can be adjusted within the same output voltage adjustment range as the output voltage adjustment by external resistor or variable resistor. For this case, output voltage can be determined by the formula shown below.

$$\text{Output Voltage} = \text{TRIM Terminal Voltage} \times \text{Nominal Output Voltage}$$



**Fig.2-3 Output Voltage Adjustment by applying external voltage**

For applications other than the above, refer to the trim circuit as shown in fig.2-4 and determine external circuit and component values.

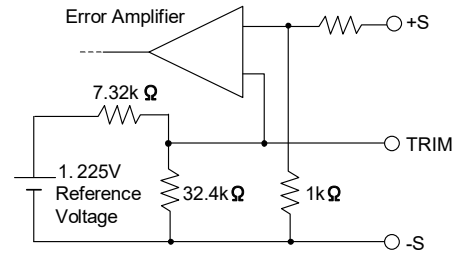

**Fig.2-4 TRIM Circuit (For the Reference)**

## 3. Maximum Output Ripple and Noise

Measured value according to the specified methods based on JEITA-9141 (Clause 7.12 and clause 7.13) which is described in the following.

Measure according to fig.3-1 connection, based on the basic connection of fig.1-2. Connect capacitors (C6: ceramic capacitor  $2.2 \mu\text{F}$ , C7: refer to table 1-1 for electrolytic capacitor values) at 50mm distance from the output terminals. Measure at ceramic capacitor (C6) leads as shown in fig.3-1 using coaxial cable with JEITA recommended attachment. Use oscilloscope with 100MHz frequency bandwidth or equivalent.

Take note that output ripple voltage and output spike noise may vary depending on PCB wiring design.

Generally, output ripple voltage and output spike noise can be reduced by increasing capacitance value of external capacitor.

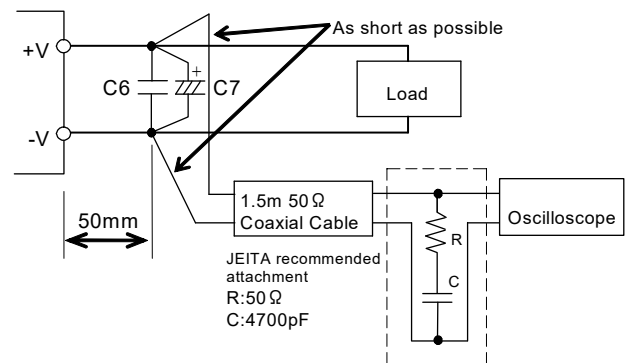

**Fig.3-1 Measurement of Maximum Output Ripple & Noise**

## 4. Maximum Line Regulation

Maximum value of output voltage change when input voltage is gradually varied (steady state) within specified input voltage range.

## 5. Maximum Load Regulation

Maximum value of output voltage change when output current is gradually varied (steady state) within specified output current range.

When using at dynamic load mode, audible noise could be heard from the power module and output voltage fluctuation might increase. A thorough pre-evaluation must be performed before using this power module.

## 6. Over Current Protection (OCP)

This power module has built-in OCP function.

Output will recover when short circuit or overload conditions are released. OCP setting value is fixed and therefore, cannot be externally adjusted.

Also, take note that power module might be damaged continuing output short circuit or over load conditions depending on thermal conditions.

## 7. Over Voltage Protection (OVP)

This power module has built-in OVP function.

OVP set point is relative to the rated output voltage value.

When OVP is triggered, output can be recovered by turning input line off and then turning it on again after input voltage drops down to 0V, or by manual reset of the control ON/OFF terminal. Reset time for ON/OFF terminal is 100ms or longer.

When verifying OVP function by applying external voltage at the output terminals, applied voltage value should not exceed specified OVP maximum value. Refer to specification table for OVP maximum value. Avoid applying external voltage that exceeds OVP maximum value because this will cause power module damage.

OVP setting value is fixed and cannot be adjusted externally.

## 8. Over Thermal Protection (OTP)

This power module has built-in OTP function. This function operates and shuts down the output when ambient temperature or internal temperature of power module abnormally rises. OTP operates at 105°C to 130°C baseplate temperature..

When OTP is triggered, output can be recovered by turning input line off and then turning it on again after input voltage drops down to 0V, or by manual reset of the control ON/OFF terminal, after temperature sufficiently decreased. Reset time for ON/OFF terminal is 100ms or longer.

## 9. Remote Sensing (+S, -S terminal)

Remote sensing terminal is provided to compensate for voltage drop across the wirings from the power module output terminal to the load input terminal.

When remote sensing function is not used (local sensing), short +S terminal to +V terminal and, -S terminal to -V terminal.

Take note that voltage compensation range for line drop (voltage drop due to wiring) is determined such that output voltage at the output terminals is within output voltage range and that voltage between -V and -S terminals is within 0.1V or less. Even for remote sensing case, use power module such that output power is within specified maximum output power. Furthermore, reduce noise effect by using shield wire, twist pair, or parallel pattern.

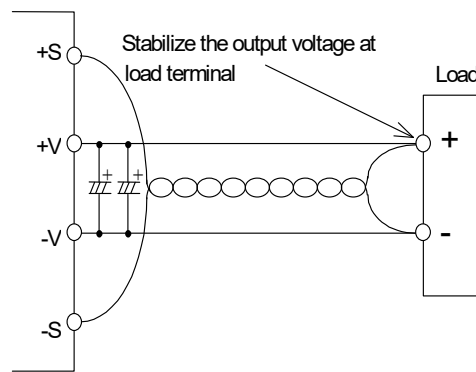

Fig.9-1 Remote Sensing at Use

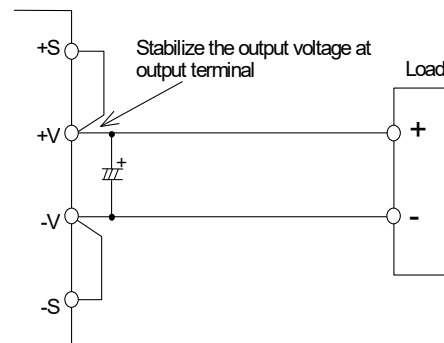

Fig.9-2 Remote Sensing Not in Use

## 10. ON/OFF Control (CNT, SG terminal)

Without turning the input supply on and off, the output can be enable and disabled using this function.

ON/OFF control circuit is on the input side (the primary side), and CNT terminal pin is used. Use the SG terminal as ground for CNT terminal. If this function is not used, short the CNT terminal and the SG terminal.

# PAF600F280-SERIES

- 1) The maximum impressed voltage for the CNT terminal is 35V and the maximum reverse voltage is 0.7V. Also the source current for CNT terminal is about 1mA. When wiring becomes long, connect a capacitor about 0.1μF value between the CNT and the SG terminal at a nearest distance.
- 2) ON/OFF terminal can be controlled by opening or closing connections (with switch or relay), or by photo-coupler ON/OFF. Also for the secondary control, isolation can be achieved through the use of a photo-coupler or equivalent.

\* When using photo-coupler, connect between the CNT and the SG terminal to make transistor side shortest.

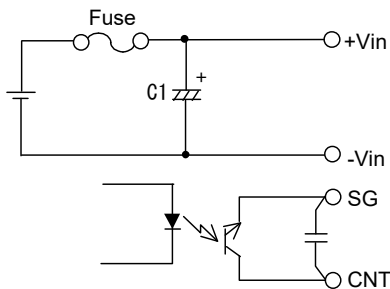

Fig.10-1 CNT,SG terminal connection

CNT Level	Output Status
H(4V and above ) or Open	OFF
L(0.8V and below ) or short	ON

Table 10-1 ON/OFF Control Mode

## 11. Parallel Operation (PC terminal)

By connecting the PC terminal of each power module, output current can be equally drawn from each module. A maximum of 11 units of the same model can be connected. Furthermore, be sure that the output power of every module does not exceed the maximum output power value. In addition, maximum output current is derated by parallel operation units as shown in Table 11-1. Note that usage of power module at out-of-rated condition might result in power module temperature abnormal rise or damage.

Parallel units	Maximum output current
2 units	95% of nominal output current
3~8 units	90% of nominal output current
9~11 units	85% of nominal output current

Table.11-1 Condition for parallel operation

Set the accuracy of the output voltage within +/-1% when adjust the output voltage for parallel operation. Refer to “Parallel Operation Application” of Application Note for Power Module Products.

When using the parallel operation function, be sure to read section “26. Parallel Operation Precautions”.

## 12. Series Operation

Series operation is possible for PAF600F280 series. Connections shown fig. 12-1 and fig. 12-2 is possible.

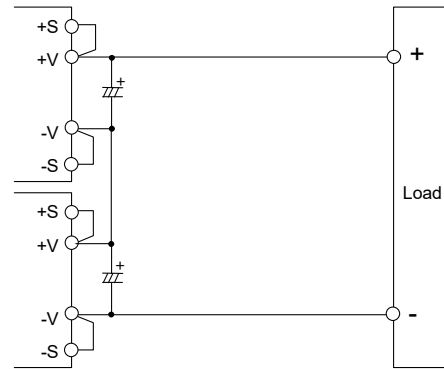

Fig.12-1 Series Operation in High Output Voltage

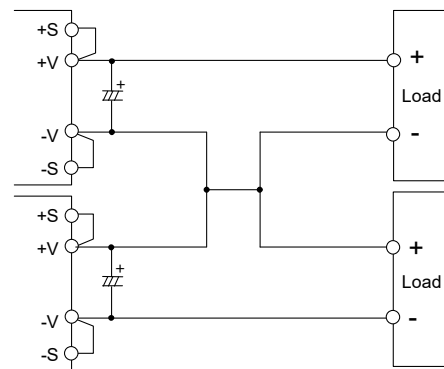

Fig.12-2 ± Output Series Operation

## 13. I.O.G. signal (IOG terminal)

Normal or abnormal operation of the power module can be monitored by using the IOG terminal. Output of this signal monitor is located at secondary side (output side) and is an open drain output.

This signal is LOW when inverter is normally operating and HIGH when inverter stops or when inverter is operating abnormally. (maximum sink current is 5mA, maximum applied voltage is 35V)

Ground for the IOG terminal is the-S terminal.

Also note that IOG becomes unstable for following conditions:

- Operation of Over Current Protection (OCP)
- Light load conditions at parallel operation
- Dynamic load operation

# PAF600F280-SERIES

## 14. Auxiliary power supply for external signals (AUX terminal)

For AUX terminal, output voltage value is within 10 ~ 14VDC range, maximum output current is 20mA. Ground for the AUX terminal is -S terminal.

Avoid short circuit of AUX terminal with other terminals as this would lead to power module damage.

## 15. Operating Ambient Temperature

There is no restriction on mounting direction but there should be enough consideration for airflow so that heat does not accumulate around the power module vicinity. Determine external components configuration and mounting direction on PCB such that air could flow through the heatsink at forced cooling and conventional cooling.

By maintaining actual baseplate temperature below 100°C, operation is possible.

For details on thermal design, refer to “Heat Dissipation Design for Power Module” of Application Note for Power Module Products.

Note) 1. Maximum baseplate temperature is 100°C.

For worst case operating condition, verify baseplate temperature at measurement point indicated in fig. 15-1.

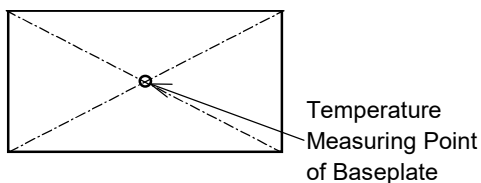

Fig.15-1 Temperature Measurement Point of Baseplate

2. There is limitation on baseplate temperature range for as shown in fig.15-2.

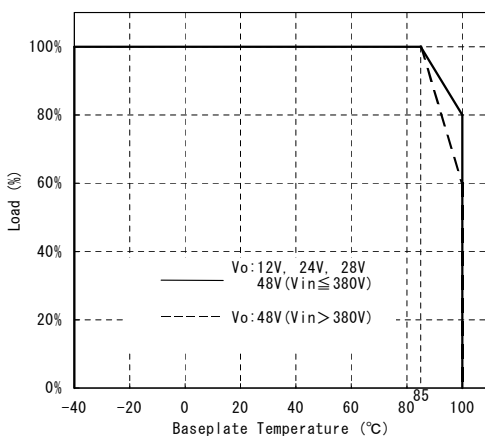

Fig.15-2 Derating curve

For better improvement of power module reliability, derating of baseplate temperature when using is recommended.

## 16. Operating Ambient Humidity

Take note that moisture could lead to power module abnormal operation or damage.

## 17. Storage Ambient Temperature

Abrupt temperature change would cause moisture formation that leads to poor solderability of each terminal of the power module.

## 18. Storage Ambient Humidity

Take enough care when storing the power module because rust which causes poor solderability would form in each terminal when stored in high temperature, high humidity environment.

## 19. Cooling Method

Operating temperature range is specified by the baseplate temperature. Therefore, several method of heat dissipation is possible.

For details on thermal design, refer to “Heat Dissipation Design for Power Module” of Application Note for Power Module Products.

## 20. Baseplate Temperature vs. Output Voltage Drift

Output voltage drift is defined as the rate of voltage change when baseplate temperature only is changed during operation.

## 21. Withstand Voltage

This power module is designed to have a withstand voltage of 2.5kVAC between input and baseplate, and 3kVAC between input and output for 1 minute.

When conducting withstand voltage test during incoming inspection, be sure to set the current limit value of the withstand voltage testing equipment to 20mA.

This power module is designed to have a withstand value of 500VDC between output and baseplate for 1 minute. When conducting withstand voltage test during incoming inspection, be sure to apply DC voltage.

# PAF600F280-SERIES

Be sure to avoid conducting test with AC voltage because this would cause power module damage.

Furthermore, avoid throw in or shut off of the testing equipment when applying or when shutting down the test voltage. Instead, gradually increase or decrease the applied voltage. Take note especially not to use the timer of the test equipment because when the timer switches the applied voltage off, impulse voltage which has several times the magnitude of the applied voltage is generated causing damage to the power module.

Connect the terminals as shown in fig.21-1, fig.21-2 and fig.21-3.

When conducting test by the basic connection shown in fig.1-2, connect the terminals similarly.

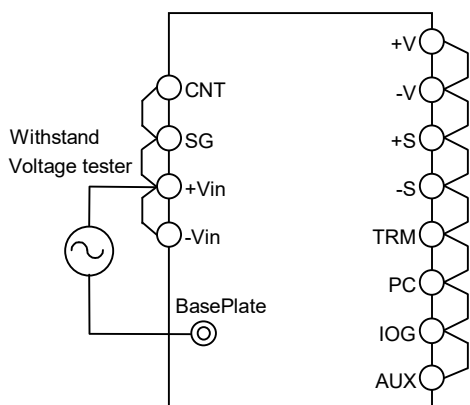

**2.5kVAC 1minute (20mA)**  
**Fig.21-1 Withstand Voltage Tester for Input-Baseplate**

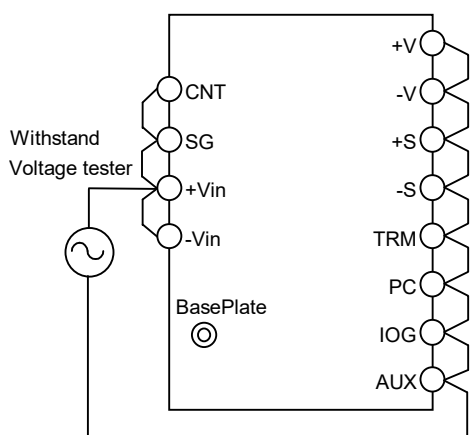

**3kVAC 1minute (20mA)**  
**Fig.21-2 Withstand Voltage Tester for Input-Output**

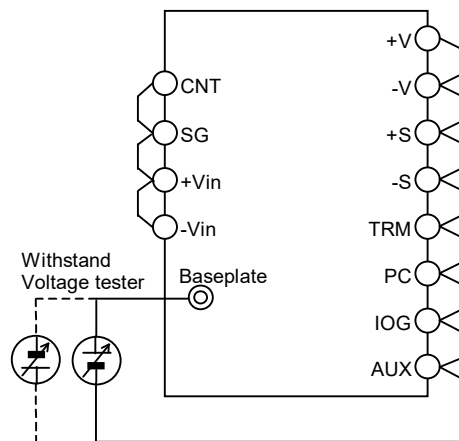

**500VDC 1minute**  
**Fig.21-3 Withstand Voltage Tester for Output-Baseplate**

## 22. Insulation Resistance

Use DC insulation tester (MAX 500V) between output and baseplate. Insulation resistance value is 100MΩ and above at 500VDC applied voltage. Also take note that depending on the insulation tester used, some testers generate high voltage pulse. Discharge the power module after test using a resistor, etc.

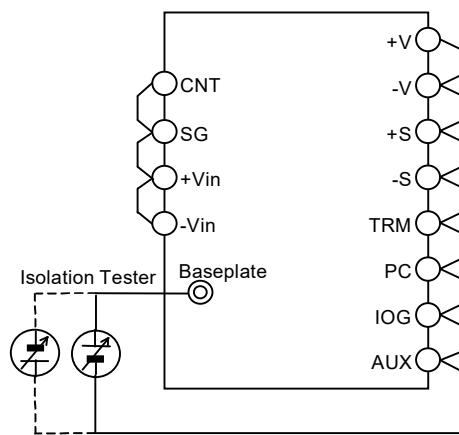

**Over 100MΩ at 500VDC**  
**Fig.22-1 Isolation Test**

## 23. Withstand Vibration

Refer to “Power Module Mounting Method on PCB” of Application Note for Power Module Products.

## 24. Withstand Shock

Withstand shock value is defined to be the value at TDK-Lambda shipment and packaging conditions.

# PAF600F280-SERIES

## 25. CE MARKING / UKCA MARKING

### CE MARKING

CE Marking, when applied to a product or packing material for a product covered by this handbook, indicates compliance with the Low Voltage Directive and RoHS Directive.

### UKCA MARKING

UKCA Marking, when applied to a product or packing material for a product covered by this handbook, indicates compliance with the Electrical Equipment (Safety) Regulations and Restriction of the Use of Certain Hazardous Substances in Electrical & Electronic Equipment Regulations.

## 26. Parallel Operation Precautions

PAF600F280 Series has implemented design change at July 2023. The design change have affected parallel operation performance. TDK-Lambda does NOT recommend mixed “Before” and “After” design change if parallel operation implemented.

“>>” indication is marked on the side label for “After” design change.

Please contact TDK-Lambda technical support if any question.



## ■ Before concluding power module damage

Verify following items before concluding power module damage.

### 1) No output voltage

- Is specified input voltage applied?
- Are the ON/OFF control terminal (CNT, SG), remote sensing terminal (+S, -S), output voltage trimming terminal (TRIM) correctly connected?
- Is output current of the auxiliary power supply for external signals terminal (AUX) within the specified value ?
- For cases where output voltage adjustment is used, is the resistor or variable resistor setting, connections correctly done?
- Are there no abnormalities in the output load used?
- Is the baseplate temperature within the specified temperature range?

### 2) Output voltage is high

- Are the remote sensing terminals (+S, -S) correctly connected?
- Is the measurement done at the sensing points?
- For cases where output voltage adjustment is used, is the resistor or volume setting, connections correctly done?

### 3) Output voltage is low

- Is specified input voltage applied?
- Are the remote sensing terminals (+S, -S) correctly connected?
- Is the measurement done at the sensing points?
- For cases where output voltage adjustment is used, is the resistor or variable resistor setting, connections correctly done?
- Are there no abnormalities in the output load used?

### 4) Load regulation and line regulation is large

- Is specified input voltage applied?
- Are the input terminals and the output terminals firmly connected?
- Is the measurement done at the sensing points?
- Is the input or output wire too thin?

### 5) Output ripple voltage is large

- Is the measuring method used the same or equivalent with the specified method in this Instruction Manual?
- Is the input ripple voltage value within the specified value?