

CCG1R5-12-xxS

RELIABILITY DATA

信頼性データ

INDEX

	PAGE
1. MTBF計算値 Calculated Values of MTBF	3
2. 部品デレーティング Components Derating	6
3. 主要部品温度上昇値 Main Components Temperature Rise ΔT List	8
4. アブノーマル試験 Abnormal Test	9
5. ノイズシミュレート試験 Noise Simulate Test	12
6. その他試験 Other Test	14

使用記号 Terminology Used

+Vin + 入力端子	+ Input Terminal
-Vin - 入力端子	- Input Terminal
RC リモートON/OFFコントロール端子	Remote ON/OFF Control Terminal
+Vout + 出力端子	+ Output Terminal
-Vout - 出力端子	- Output Terminal
TRM 出力電圧外部可変用端子	Output Voltage Adjustment Terminal
FG フレームグラウンド	Frame GND
 接地	Earth

※記載のデータは代表機種での測定結果ですが、全ての製品はほぼ同等の特性です。

当社標準測定条件における結果であり、参考値としてお考え願います。

The data is the measurement result of a representative model,

but all products show almost the same characteristics.

Test results are reference data based on our standard measurement condition.

1. MTBF計算値 Calculated Values of MTBF

MODEL : CCG1R5-12-05S, CCG1R5-12-12S

(1) 算出方法 Calculating Method

Telcordiaの部品ストレス解析法(*1)で算出されています。

故障率 λ_{ss} は、それぞれの部品ごとに電気ストレスと動作温度によって決定されます。

Calculated based on parts stress reliability prediction of Telcordia(*1).

Individual failure rate λ_{ss} is calculated by the electric stress and temperature rise of the each devices.

*1: Telcordia document “Reliability Prediction Procedure for Electronic Equipment”
(Document number SR-332,Issue3)

$$\text{<算出式>} \quad MTBF = \frac{1}{\lambda_{equip}} = \frac{1}{\pi_E \sum_{i=1}^m N_i \cdot \lambda_{ssi}} \times 10^9 \quad \text{時間 (hours)}$$

$$\lambda_{ssi} = \lambda_{Gi} \cdot \pi_{Qi} \cdot \pi_{Si} \cdot \pi_{Ti}$$

λ_{equip} : 全機器故障率 (FITs)
Total Equipment failure rate (FITs = Failures in 10^9 hours)

λ_{Gi} : i番目の部品に対する基礎故障率
Generic failure rate for the ith device

π_{Qi} : i番目の部品に対する品質ファクタ
Quality factor for the ith device

π_{Si} : i番目の部品に対するストレスファクタ
Stress factor for the ith device

π_{Ti} : i番目の部品に対する温度ファクタ
Temperature factor for the ith device

m : 異なる部品の数
Number of different device types

N_i : i番目の部品の個数
Quantity of ith device type

π_E : 機器の環境ファクタ
Equipment environmental factor

(2) MTBF値 MTBF Values

条件 Conditions

- ・ 入力電圧 : 12VDC ・ 環境ファクタ : GF (Ground, Fixed)
- Input Voltage Environmental Factor

(2)-1 CCG1R5-12-05S

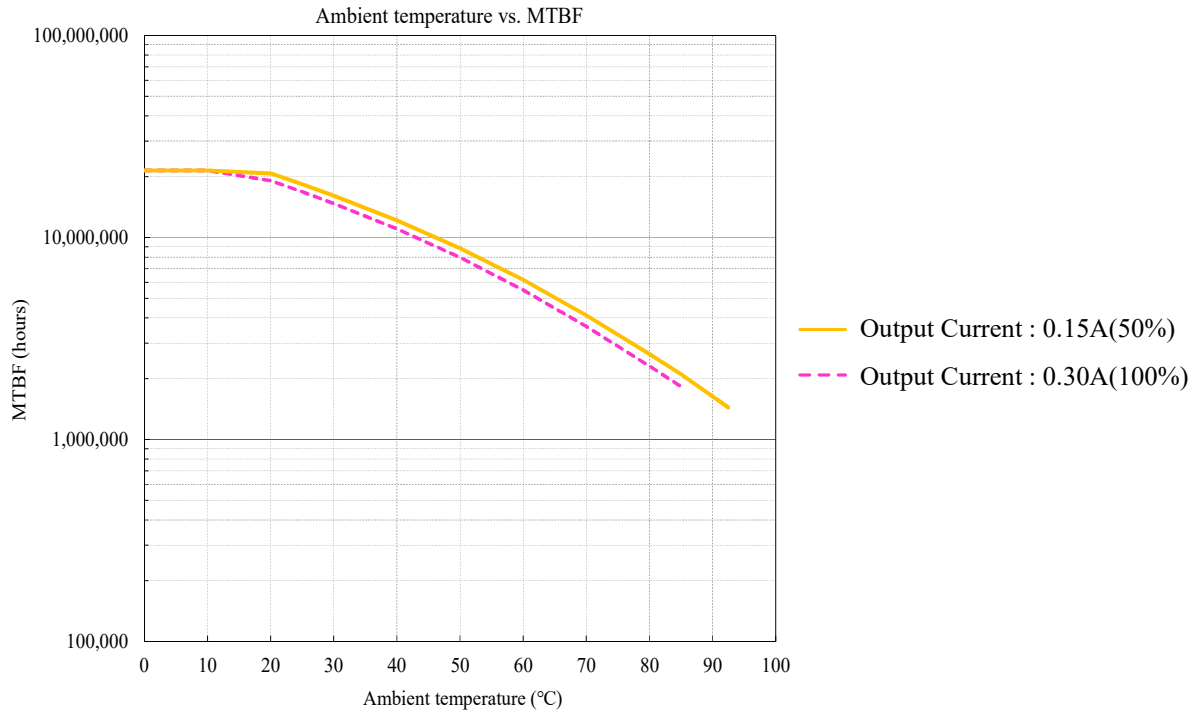

Ambient temperature	MTBF	
	Output Current : 0.15A (50%)	Output Current : 0.30A (100%)
25°C	18,357,993 (hours)	16,841,240 (hours)
40°C	12,152,516 (hours)	11,047,098 (hours)
60°C	6,179,885 (hours)	5,495,029 (hours)
85°C	2,103,263 (hours)	1,832,308 (hours)
92.5°C	1,442,776 (hours)	-

(2)-2 CCG1R5-12-12S

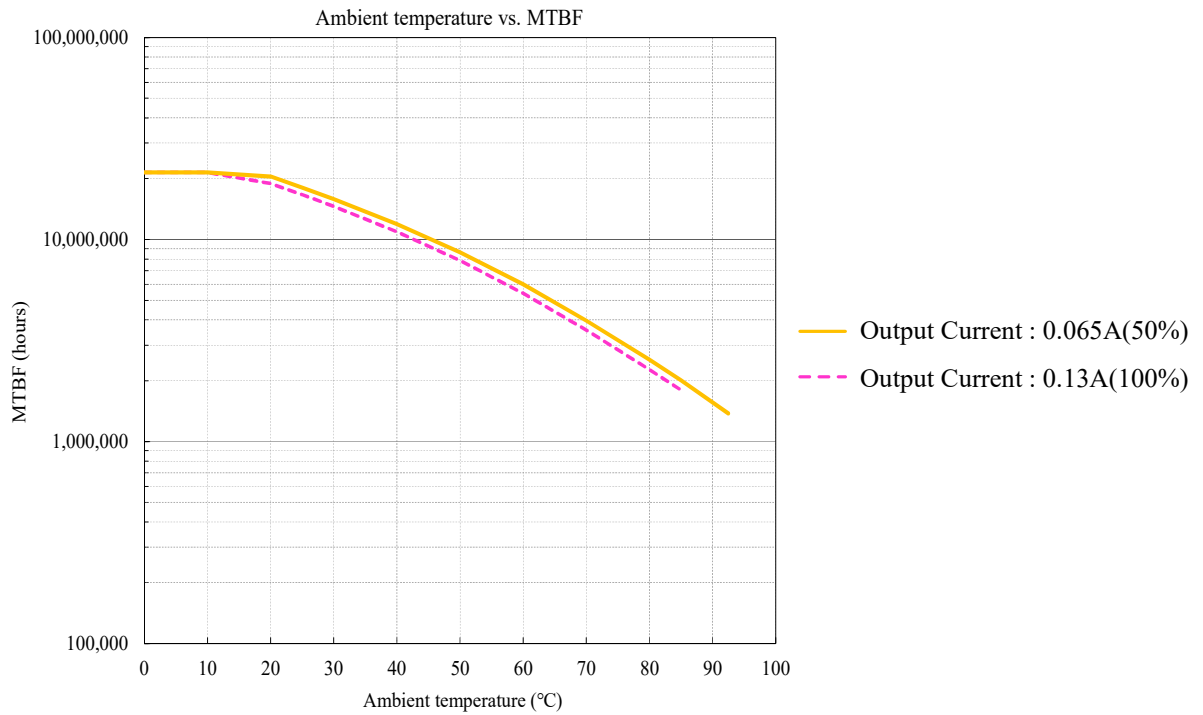

Ambient temperature	MTBF	
	Output Current : 0.065A (50%)	Output Current : 0.13A (100%)
25°C	18,058,969 (hours)	16,666,410 (hours)
40°C	11,917,471 (hours)	10,929,488 (hours)
60°C	5,994,916 (hours)	5,416,651 (hours)
85°C	2,012,333 (hours)	1,797,075 (hours)
92.5°C	1,377,182 (hours)	-

2. 部品デイレートイング Components Derating

MODEL : CCG1R5-12-05S, CCG1R5-12-12S

(1) 算出方法 Calculating Method

(a) 測定方法 Measuring Method

・ 入力電圧 Input Voltage	: 12VDC	・ 出力電流 Output Current	: CCG1R5-12-05S 0.3A (100%) CCG1R5-12-12S 0.13A (100%)
・ 周囲温度 Ambient Temperature	: 85°C	・ 冷却法 Cooling	: 自然空冷 Natural Convection
・ 取り付け Mounting	: 水平置き Horizontal		

(b) 半導体 Semiconductors

ケース温度、消費電力、熱抵抗より使用状態の接合点温度を求め最大定格、接合点温度との比較を求めました。

Compared with maximum junction temperature and actual one which is calculated based on case temperature, power dissipation and thermal impedance.

(c) IC、抵抗、コンデンサ等 IC, Resistors, Capacitors, etc.

周囲温度、使用状態、消費電力など、個々の値は設計基準内に入っています。

Ambient temperature, operating condition, power dissipation and so on are within derating criteria.

(d) 熱抵抗算出方法 Calculating method of thermal impedance

$$\theta_{j-c} = \frac{T_j(\max) - T_c}{P_j(\max)} \quad \theta_{j-a} = \frac{T_j(\max) - T_a}{P_j(\max)} \quad \theta_{j-l} = \frac{T_j(\max) - T_l}{P_j(\max)}$$

T_c : デイレートイングの始まるケース温度 一般に25°C
Case Temperature at Start Point of Derating; 25°C in General

T_a : デイレートイングの始まる周囲温度 一般に25°C
Ambient Temperature at Start Point of Derating; 25°C in General

T_l : デイレートイングの始まるリード温度 一般に25°C
Lead Temperature at Start Point of Derating; 25°C in General

$P_j(\max)$: 最大接合点(チャンネル)損失
($P_{ch}(\max)$) Maximum Junction (channel) Dissipation

$T_j(\max)$: 最大接合点(チャンネル)温度
($T_{ch}(\max)$) Maximum Junction (channel) Temperature

θ_{j-c} : 接合点(チャンネル)からケースまでの熱抵抗
(θ_{ch-c}) Thermal Impedance between Junction (channel) and Case

θ_{j-a} : 接合点から周囲までの熱抵抗
(θ_{ch-a}) Thermal Impedance between Junction (channel) and Air

θ_{j-l} : 接合点からリードまでの熱抵抗
(θ_{ch-l}) Thermal Impedance between Junction (channel) and Lead

(2) 部品ダイレーティング表 Components Derating List

(2)-1 CCG1R5-12-05S

部品番号 Location No.	部品名 Part Name	最大定格 Maximum Rating	使用状態 Actual Rating	ダイレーティング率 Derating Factor
Q1	CHIP MOS FET	Tj(max): 150°C	Tj: 102.8°C	68.5%
D101	CHIP SBD	Tj(max): 150°C	Tj: 107.3°C	71.5%
A1	CHIP IC	Tj(max): 150°C	Tj: 101.7°C	67.8%
A101	CHIP IC	Tj(max): 150°C	Tj: 96.8°C	64.5%
PC1	CHIP COUPLER	Tj(max): 125°C	Tj: 98.1°C	78.5%

(2)-2 CCG1R5-12-12S

部品番号 Location No.	部品名 Part Name	最大定格 Maximum Rating	使用状態 Actual Rating	ダイレーティング率 Derating Factor
Q1	CHIP MOS FET	Tj(max): 150°C	Tj: 105.1°C	70.1%
D101	CHIP SBD	Tj(max): 150°C	Tj: 103.9°C	69.2%
A1	CHIP IC	Tj(max): 150°C	Tj: 101.7°C	67.8%
A101	CHIP IC	Tj(max): 150°C	Tj: 96.8°C	64.5%
PC1	CHIP COUPLER	Tj(max): 125°C	Tj: 98.1°C	78.5%

3. 主要部品温度上昇値 Main Components Temperature Rise ΔT List

MODEL : CCG1R5-12-05S, CCG1R5-12-12S

(1) 測定条件 Measuring Conditions

・ 入力電圧 Input Voltage	: 12VDC	・ 出力電流 Output Current	: CCG1R5-12-05S 0.3A (100%) CCG1R5-12-12S 0.13A (100%)
・ 周囲温度 Ambient Temperature	: 85°C	・ 冷却法 Cooling	: 自然空冷 Natural Convection
・ 取り付け Mounting	: 水平置き Horizontal		

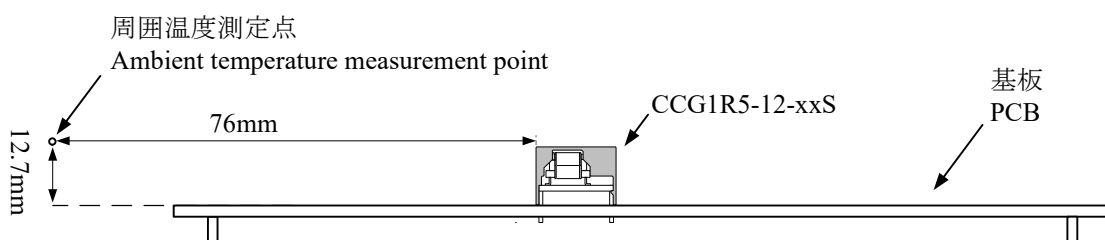

(2) 測定結果 Measuring Results

(2)-1 CCG1R5-12-05S

部品番号 Location No.	部品名 Part Name	温度上昇値 ΔT Temperature Rise
Q1	CHIP MOS FET	16.9°C
D101	CHIP SBD	14.9°C
A1	CHIP IC	16.5°C
A101	CHIP IC	11.5°C
PC1	CHIP COUPLER	12.2°C
L1	CHOKE COIL	10.4°C
T1	TRANS, PULSE	15.5°C

(2)-2 CCG1R5-12-12S

部品番号 Location No.	部品名 Part Name	温度上昇値 ΔT Temperature Rise
Q1	CHIP MOS FET	18.8°C
D101	CHIP SBD	15.3°C
A1	CHIP IC	17.9°C
A101	CHIP IC	12.6°C
PC1	CHIP COUPLER	12.7°C
L1	CHOKE COIL	10.2°C
T1	TRANS, PULSE	16.1°C

4. アブノーマル試験 Abnormal Test

MODEL : CCG1R5-12-05S, CCG1R5-12-12S

(1) 試験条件 Test Conditions

- ・ 入力電圧 : 18VDC
Input Voltage
- ・ 出力電流 : CCG1R5-12-05S 0.3A (100%)
Output Current CCG1R5-12-12S 0.13A (100%)
- ・ 周囲温度 : 25°C
Ambient Temperature

(2) 試験回路 Test Circuit

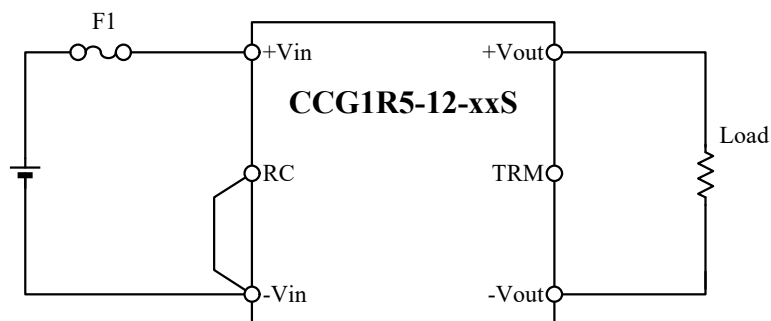

- ・ ヒューズ (F1) : 3.15A (DC86V11CT 3.15A, SOC)
Fuse

(3) 試験結果 Test Results

(3)-1 CCG1R5-12-05S

(Da:Damaged)

No.	Test position		Test mode		Test result											記事 Note	
	部品No. Location No.	試験端子 Test point	ショート Short	オープン Open	a 発火 Fire	b 発煙 Smoke	c 破裂 Burst	d 異臭 Smell	e 赤熱 Red hot	f 破損 Damaged	g ヒューズ断 Fuse blown	h OVP	I OCP	j 出力断 No output	k 変化なし No change		l その他 Others
1	Q1	D-S	●								●			●			
		D-G	●							●	●			●			Da:A1,R35,SH1
		G-S	●											●			
		D		●										●			
		S		●										●			
		G		●									●				
2	D101	A-K	●										●				
		A/K		●										●			
3	PC1	1-2	●										●		●	出力電圧増加 Output voltage increase	
		3-4	●										●				
		1		●									●		●	出力電圧増加 Output voltage increase	
		2		●									●		●	出力電圧増加 Output voltage increase	
		3		●									●		●	出力電圧増加 Output voltage increase	
		4		●								●		●	出力電圧増加 Output voltage increase		
4	L1		●												●		
				●									●				
5	T1	1-2	●								●		●				
		2-3	●										●				
		3-4	●								●		●				
		5-6	●											●			
		6-7	●										●				
		7-8	●												●		
		1		●											●		
		2		●											●		
		3		●											●		
		4		●											●		
		5		●											●	効率低下 Efficiency down	
		6		●											●	効率低下 Efficiency down	
		7		●											●	効率低下 Efficiency down	
		8		●										●	効率低下 Efficiency down		

(3)-2 CCG1R5-12-12S

(Da:Damaged)

No.	Test position		Test mode		Test result											記事 Note	
	部品No. Location No.	試験端子 Test point	ショート Short	オープン Open	a	b	c	d	e	f	g	h	I	j	k		l
					発火 Fire	発煙 Smoke	破裂 Burst	異臭 Smell	赤熱 Red hot	破損 Damaged	ヒューズ断 Fuse blown	OVP	OPP	出力断 No output	変化なし No change		その他 Others
1	Q1	D-S	●								●			●			
		D-G	●							●	●			●			Da:A1,R35,SH1
		G-S	●											●			
		D		●										●			
		S		●										●			
2	D101	A-K	●										●				
		A/K		●										●			
3	PC1	1-2	●										●			● 出力電圧増加 Output voltage increase	
		3-4	●										●				
		1		●									●			● 出力電圧増加 Output voltage increase	
		2		●									●			● 出力電圧増加 Output voltage increase	
		3		●									●			● 出力電圧増加 Output voltage increase	
4	L1		●												●		
				●										●			
5	T1	1-2	●								●			●			
		2-3	●										●				
		3-4	●								●			●			
		5-6	●												●		
		6-7	●										●				
		7-8	●												●		
		1		●											●		
		2		●											●		
		3		●											●		
		4		●											●		
		5		●												● 効率低下 Efficiency down	
		6		●												● 効率低下 Efficiency down	
		7		●												● 効率低下 Efficiency down	
8		●												● 効率低下 Efficiency down			

5. ノイズシミュレート試験 Noise Simulate Test

MODEL : CCG1R5-12-03S, CCG1R5-12-15S

(1) 使用装置 Equipment Used

- ・ ノイズシミュレーター : INS-AX2-450TH (Noise Laboratory)
Noise Simulator
- ・ カップリングクランプ : CA-805B (Noise Laboratory)
Coupling Clamp

(2) 供試電源台数 The number of D.U.T. (Device Under Test)

- ・ CCG1R5-12-03S : 1台 (1unit)
- ・ CCG1R5-12-15S : 1台 (1unit)

(3) 試験条件 Test Conditions

- ・ 入力電圧 : 12VDC
Input Voltage
- ・ 出力電圧 : 定格
Output Voltage Rated
- ・ 出力電流 : CCG1R5-12-03S 0A,0.4A (0%,100%)
Output Current CCG1R5-12-15S 0A,0.1A (0%,100%)
- ・ 極性 : +、-
Polarity
- ・ ノイズ電圧 : 入力ポート 2kV、信号ポート 0.75kV
Noise Level Input Port 2kV, Signal Port 0.75kV
- ・ 印加モード : 入力ポート ノーマル、信号ポート コモン
Mode Input Port Normal, Signal Port Common
- ・ パルス幅 : 50~1000ns
Pulse Width
- ・ トリガ選択 : Line
Trigger Select
- ・ 周囲温度 : 25°C
Ambient Temperature

(4) 判定条件 Acceptable Conditions

1. 試験中、5%を超える出力電圧の変動のない事
The regulation of output voltage must not exceed 5% of initial value during test.
2. 試験後の出力電圧は初期値から変動していない事
The output voltage must be within the regulation of specification after the test.
3. 発煙・発火のない事
Smoke and fire are not allowed.

(5) 試験回路 Test Circuit

- A. 入力ポート(+Vin、-Vin)に規定のインパルス・ノイズをノーマルモードで印加する
Apply the specified Impulse Noise to the Input Ports(+Vin, -Vin) with Normal Mode.

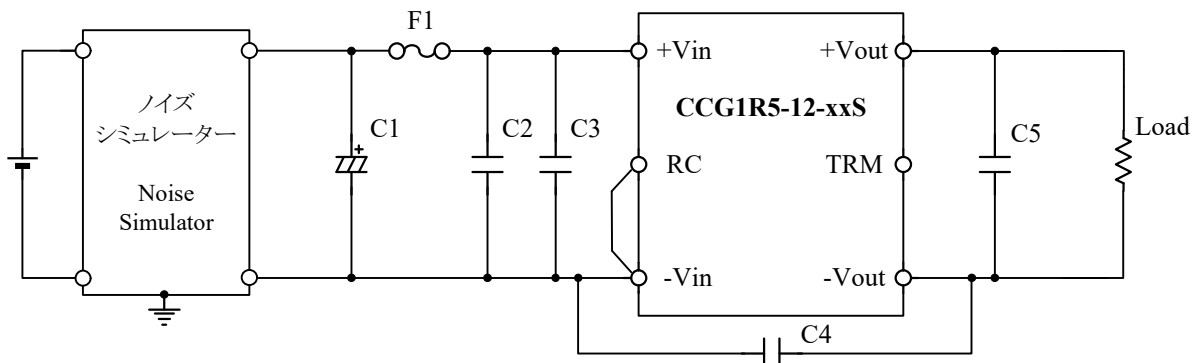

- B. 信号ポート(RC、-Vin、TRM、+Vout、-Vout)に規定のインパルス・ノイズをコモンモードで印加する
Apply the specified Impulse Noise to the Signal Ports(RC,-Vin,TRM,+Vout,-Vout) with Common Mode.

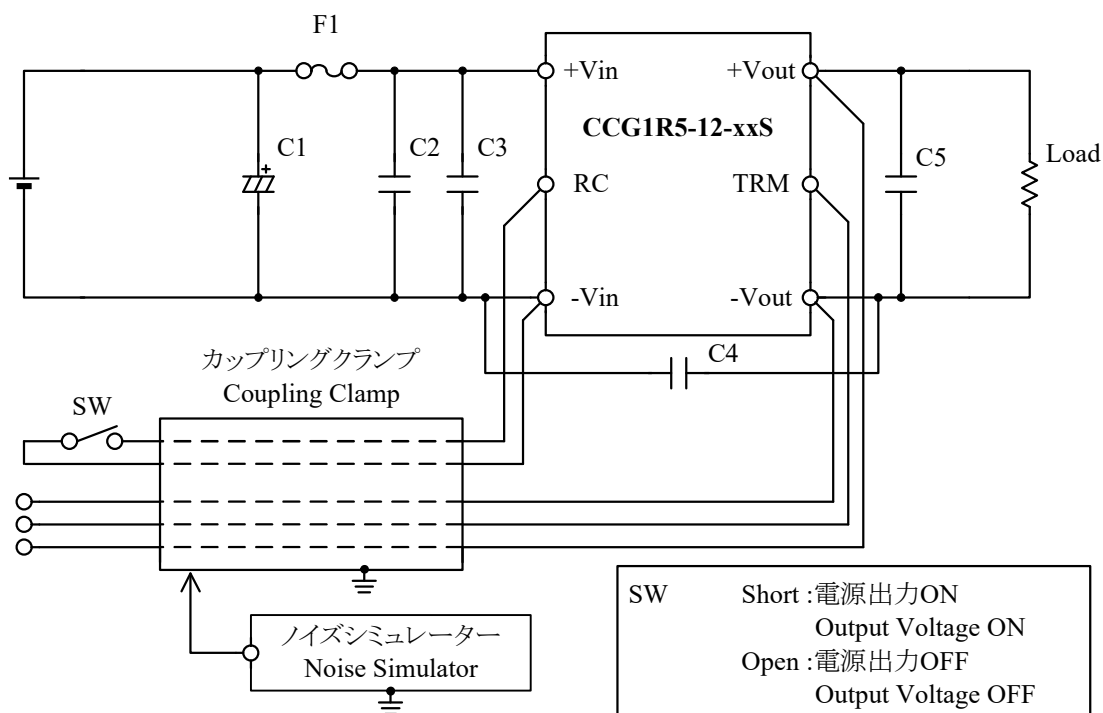

- 電解コンデンサ (C1) : 25V 47 μ F (ELXZ250ELL470MFB5D, Nippon Chemi-Con)
Electrolytic Cap.
- セラミックコンデンサ (C2, C3) : 25V 10 μ F (C3216X7R1E106K, TDK)
Ceramic Cap.
- セラミックコンデンサ (C4) : 2kV 1000pF (C4520X7R3D102K, TDK)
Ceramic Cap.
- セラミックコンデンサ (C5) : 25V 10 μ F (C3216X7R1E106K, TDK)
Ceramic Cap
- ヒューズ (F1) : 3.15A (DC86V11CT 3.15A, SOC)
Fuse

(6) 試験結果 Test Results

合格 OK

6. その他試験 Other Test

- ・ 振動試験 Vibration Test
- ・ 衝撃試験 Shock Test
- ・ はんだ耐熱性試験 Resistance to Soldering Heat Test
- ・ 熱衝撃試験 Thermal Shock Test
- ・ 高温加湿通電試験 High Temperature and High Humidity Bias Test
- ・ 高温連続通電試験 High Temperature Bias Test

上記試験結果は、CCG3-12-xxSの信頼性データをご参照下さい。
For the above test results, refer to the reliability data of CCG3-12-xxS.