

CCG10-48-xxS

C306-01-01B

SPECIFICATIONS

ITEMS		MODEL	CCG10-48-03S	CCG10-48-05S	CCG10-48-12S	CCG10-48-15S
INPUT						
Input Voltage Range		VDC	18 - 76			
Efficiency (Typ)	(*1)	%	87	89	90	90
Input Current (Typ)	(*1)	A	0.205	0.234	0.250	0.243
OUTPUT						
Nominal Output Voltage		VDC	3.3	5	12	15
Output Voltage Accuracy	(*1)	%	±2			
Maximum Output Current		A	2.6	2	0.9	0.7
Maximum Output Power		W	8.58	10	10.8	10.5
Maximum Line Regulation	(*2)	mV	20	20	48	60
Maximum Load Regulation	(*3)	mV	20	20	48	60
Temperature Coefficient		-	0.02%/°C			
Maximum Ripple & Noise	(*4)	mV	120	120	120	120
Output Voltage Range	(*4)	VDC	3.135 - 3.63	4.75 - 5.5	11.4 - 13.2	14.25 - 16.5
Over Current Protection	(*5)	-	105% min.			
Over Voltage Protection		-	None			
FUNCTION						
Remote ON/OFF Control	(*6)	-	Possible			
Remote Sensing		-	None			
Parallel Operation		-	None			
Series Operation	(*6)	-	Possible			
ENVIRONMENT						
Operating Temperature	(*7)	-	-40°C - +90°C			
Storage Temperature		-	-55°C - +125°C			
Operating Humidity		-	5 - 95%RH (No Condensing)			
Storage Humidity		-	5 - 95%RH (No Condensing)			
Vibration	(*8)	-	At No Operating, 10-55Hz (Sweep for 1min.) Amplitude 1.65 mm Constant (Maximum 98m/s ²) X,Y,Z 1 hour each			
Shock	(*8)	-	490.3m/s ²			
Cooling		-	Convection Cooling / Forced Air Cooling			
ISOLATION						
Withstand Voltage	(*9)	-	Input - Output : 1.5kVDC (20mA) 1min. or 1.0kVAC (20mA) 1min.			
Isolation Resistance		-	More than 100MΩ at 25°C and 70%RH, Input - Output 500VDC			
STANDARD AND COMPLIANCE						
Safety		-	Approved by IEC/EN/UL/CSA62368-1 (Altitude ≤ 5,000m)			
MECHANICAL						
Weight (Typ.)		g	4			
Size (W x H x D)		mm	DIP : 19.0 x 11.5 x 12.4 / SMD : 19.0 x 11.8 x 12.4 (Refer to Outline Drawing)			

*Read Instruction Manual carefully, before using the power supply unit.

=NOTES=

- *1. At 48VDC input voltage and maximum output current. (Ambient Temperature = +25°C.)
- *2. 18 - 76VDC input voltage, constant load.
- *3. No Load - Full Load, constant input voltage.
- *4. External components are needed for operation. (Refer to Instruction Manual.)
- *5. OCP TYPE : Hiccup, Automatic recovery.
- *6. Refer to Instruction Manual.
- *7. Rating - Refer to Output Derating Curve in Instruction Manual.
- *8. The result is evaluated by TDK-Lambda standard measurement conditions.
The final equipment should be evaluated to meet its requirements.
- *9. This specification applies to power supply module as stand-alone.

CCG10-48-xxS

C306-01-02

BASIC CONNECTION

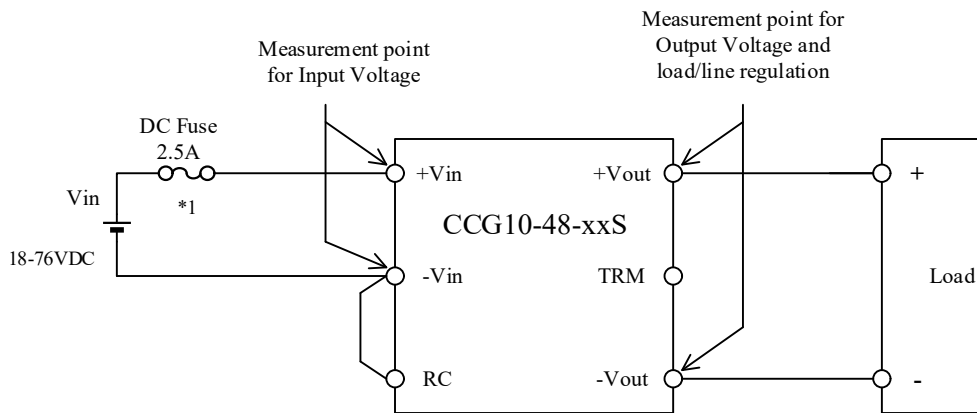

*Read instruction manual carefully, before using the power supply unit.

==NOTES==

*1. Use an external DC fuse for each unit.