

CN100B110

SPECIFICATIONS

CA952-01-01/100

ITEMS	MODEL	CN100B110 -5	CN100B110 -12	CN100B110 -15	CN100B110 -24	CN100B110 -48
INPUT						
Input Voltage Range	(*7) VDC	43 - 160				
Efficiency (Typ.)	(*1) %	91.0	92.0	91.5	90.5	90.5
Input Current (Typ.)	(*1) A	1.01	1.01	1.01	1.02	1.02
OUTPUT						
Nominal Output Voltage	VDC	5	12	15	24	48
Output Voltage Accuracy	(*1) %	-/+ 1				
Maximum Output Current	A	20	8.4	6.7	4.2	2.1
Maximum Output Power	W	100	100.8	100.5	100.8	100.8
Maximum Line Regulation	(*2)(*8) mV	10	24	30	48	96
Maximum Load Regulation	(*3)(*8) mV	10	24	30	48	96
Temperature Coefficient	-	0.02%/°C				
Maximum Ripple & Noise	(*8) mVp-p	100	150	150	240	480
Output Voltage Range	(*8) VDC	4 - 6	9.6 - 14.4	12 - 18	19.2 - 28.8	38.4 - 57.6
Over Current Protection	(*4) %	102 - 150				
Over Voltage Protection	(*5)(*7) %	125 - 145				
FUNCTION						
Remote ON/OFF Control	(*7) -	Possible				
Remote Sensing	(*7) -	Possible				
Parallel Operation	(*7) -	-				
Series Operation	(*7) -	Possible				
ENVIRONMENT						
Operating Temperature	(*6)(*7) -	-40°C - +100°C (Baseplate)				
Storage Temperature	-	-40°C - +100°C				
Operating Humidity	-	5 - 95%RH (No Condensing)				
Storage Humidity	-	5 - 95%RH (No Condensing)				
Vibration	-	At No Operating, 10 - 55Hz (Sweep for 1min.) Amplitude 0.825mm Constant (Maximum 49.0m/s ²) X,Y,Z 1 hour each IEC61373-Category 1-Grade B				
Shock	-	196.1m/s ²				
Cooling	-	Conduction Cooled				
ISOLATION						
Withstand Voltage	(*9) -	Input-Baseplate : 2.5kVAC for 1min (20mA), Input-Output: 3.0kVAC for 1min (20mA). Output-Baseplate: 500VAC for 1min (20mA)				
Isolation Resistance	-	More than 100MΩ at 25°C and 70%RH Output-Baseplate...500VDC				
STANDARD AND COMPLIANCE						
Safety	-	IEC/EN/UL/CSA62368-1 approval is in progressing.				
MECHANICAL						
Weight (Typ.)	g	60				
Size (W x H x D)	mm	37.5 x 12.7 x 58.3 (Refer to Outline Drawing)				

*Read Instruction Manual carefully, before using the power supply unit.

=NOTES=

*1. At 110VDC and maximum output current.
(Baseplate Temperature = +25°C)

*2. 43 - 160VDC, Constant load.

*3. No Load - Full Load, Constant input voltage.

*4. Constant current limiting before LVP trigger.

Delay hiccup when left in OCP condition with the output voltage less than LVP level. Refer to Instruction Manual.)

*5. Automatic recovery.

*6. Ratings - Refer to Derating Curve (CA952-01-03/100 _).
- Load(%) is percent of maximum output current.

*7. Refer to Instruction Manual.

*8. External components are necessary for operation.

(Refer to Basic Connection and Instruction Manual.)

*9. This specification applies to power supply module as stand-alone.

CN100B110

CA952-01-02/100

BASIC CONNECTION

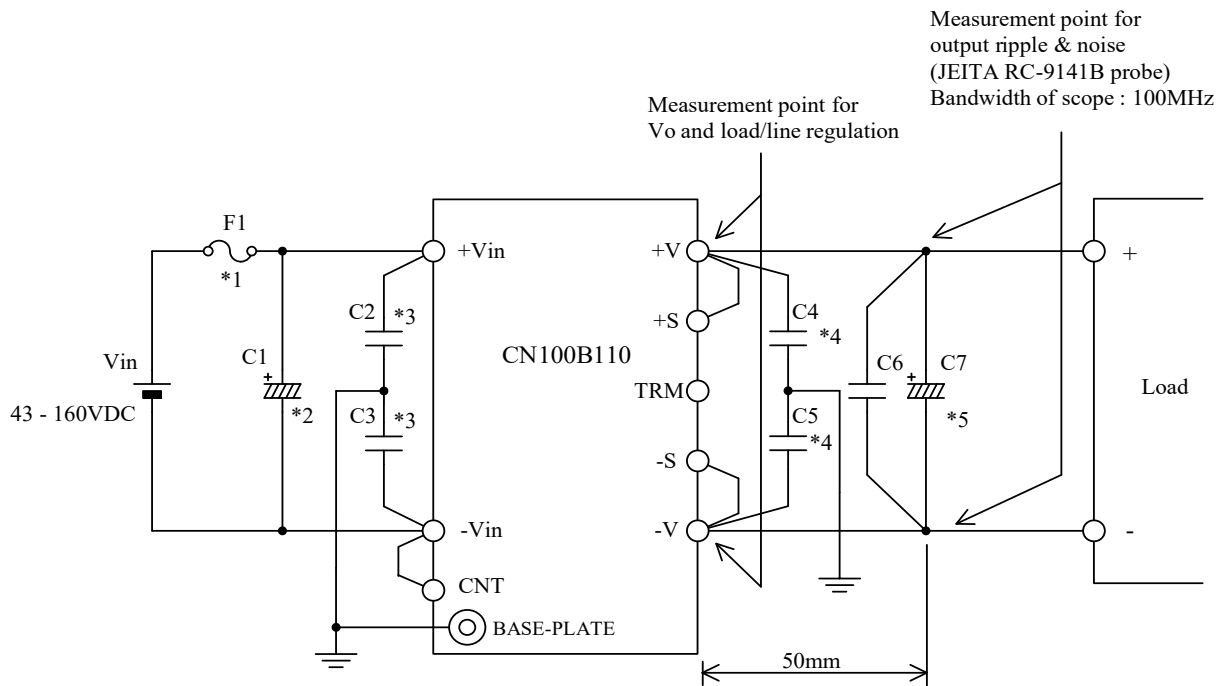

External Components list

F1:	10A		5V	1000uF	(Solid Cap.)
C1:	100uF (Elec. Cap.)	C7:	12V	680uF	(Solid Cap.)
C2:	4700pF (Ceramic Cap.)		15V	680uF	(Solid Cap.)
C3:	4700pF (Ceramic Cap.)		24V	220uF	(Elec. Cap.)
C4:	0.022uF (Film. Cap.)		48V	220uF x2 Series	(Elec. Cap.)
C5:	0.022uF (Film. Cap.)				
C6:	2.2uF (Ceramic Cap.)				

*Read instruction manual carefully, before using the power supply unit.

==NOTES==

- *1. Use an external fuse (fast blow type or normal blow type) for each unit.
- *2. Put input capacitor.
 - 1) Use low impedance electrolytic capacitor with excellent temperature characteristics.
 - 2) Use two capacitors in parallel when ambient temperature is -20°C or lower to reduce ESR.
 - 3) If the impedance of input line is high, C1 capacitance must be more than above.
- *3. Put FG capacitor.

Put these capacitors as close as possible to Vin and BASE-PLATE.
- *4. Put FG capacitor.

Put these capacitors as close as possible to Vo and BASE-PLATE.
- *5. Put output capacitor.
 - 1) Use low impedance electrolytic capacitor with excellent temperature characteristics.
 - 2) Use more than twice recommended capacitor above in parallel for 24V and 48V when ambient temperature is -20°C or lower to reduce ESR.

CN100B110

CA952-01-03/100

DERATING CURVE :

Derating Curve: Tb V.S Load

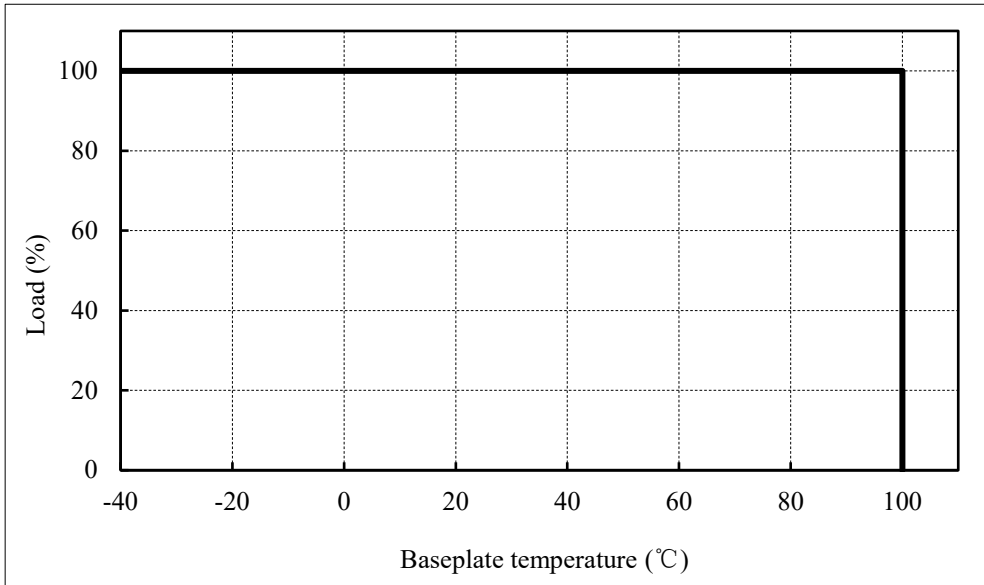

Output Voltage Trim up Range Limited v.s Input Voltage

